

creo
Creo Parametric 2.0
DO NOT REUSE
EXCEPT BY CAD

REVISIONS

P	LTR	DESCRIPTION	DATE	DWN	APVD
	A	CHANGE STATUS ECO-15-011808	17AUG2015	NCL	NMS
	A1	REVISED DRAWING ECO-15-012499	31AUG2015	NCL	NMS
	A2	REVISED DRAWING ECO-15-012631	01SEP2015	NCL	NMS

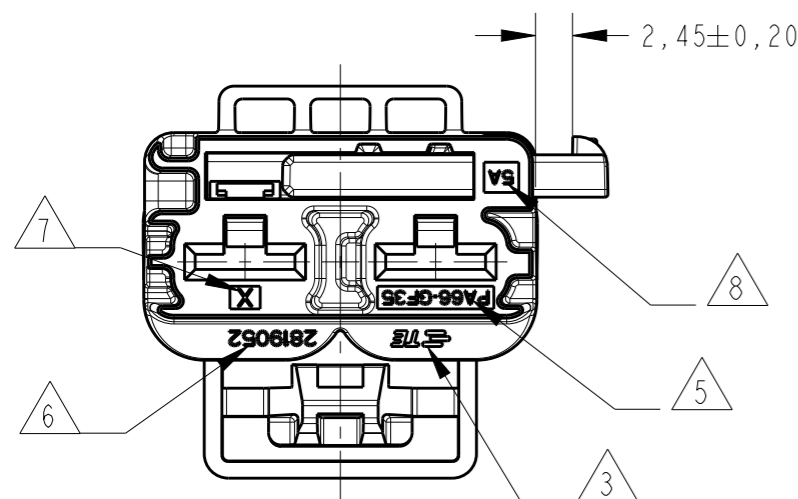

SCALE 2:1

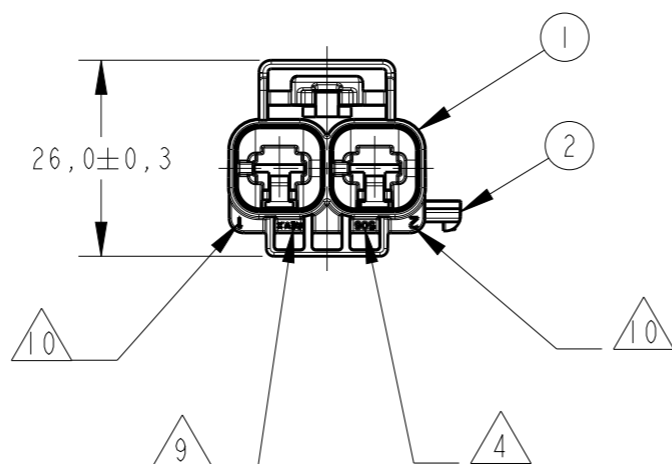
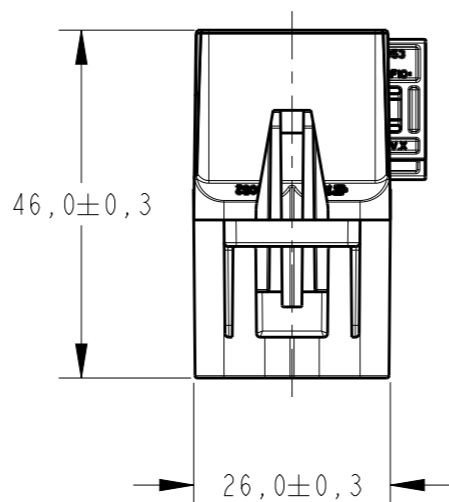

- 1 - UTILIZA TERMINAL LEAR:
6.3 HC TERMINAL ASSEMBLY_WELDED VERSION-PN:E02428900
- ASSEMBLY WITH LEAR TERMINAL:
6,3 HC TERMINAL ASSEMBLY_WELDED VERSION-PN: E02428900
- 2 - PRODUTO CONFORME FORNECIDO.
- PRODUCT AS PROVIDED.

GRAVAÇÕES MARKINGS	
3	LOGOTIPO TE TE LOGO
4	CÓDIGO PAÍS PRODUTOR MANUFACTURER COUNTRY CODE
5	NOMENCLATURA MATERIAL MATERIAL NOMENCLATURE
6	NÚMERO COMPONENTE TE TE COMPONENT NUMBER
7	NÚMERO CAVIDADE CAVITY NUMBER
8	DATADOR DATE CODE
9	REV+ LETRA REV.DA PEÇA REV.+ PART REV.LETTER
10	IDENTIFICAÇÃO DE CIRCUITO CIRCUIT NUMBER

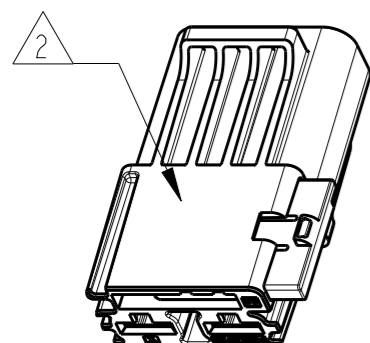

POSIÇÃO DE PRÉ-TRAVAMENTO
(PRE-LOCK POSITION)

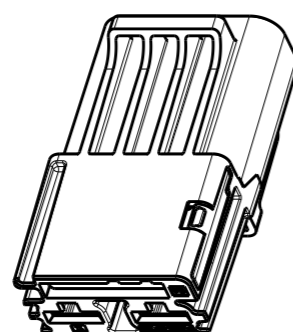

POSIÇÃO DE TRAVAMENTO
(LOCKED POSITION)

REQ.PER ASSY	ITEM	DESCRIPTION	MATERIAL	FINISH
	1	TPA	PBT-GF10	AZUL / BLUE
	1	2 WAYS CONNECTOR	PBT-GF10	PRETO / BLACK
	-1			
2819047				

THIS DRAWING IS A CONTROLLED DOCUMENT.		DWN P.PULGROSSI 17FEB2014	 TE Connectivity											
DIMENSIONS: mm		CHK J.R.GOLDSCHMIDT 17FEB2014												
TOLERANCES UNLESS OTHERWISE SPECIFIED:		APVD N.M.SANTOS 17FEB2014												
<table border="0"> <tr><td>0 PLC</td><td>±-</td></tr> <tr><td>1 PLC</td><td>±-</td></tr> <tr><td>2 PLC</td><td>±-</td></tr> <tr><td>3 PLC</td><td>±-</td></tr> <tr><td>4 PLC</td><td>±-</td></tr> <tr><td>ANGLES</td><td>±-</td></tr> </table>		0 PLC		±-	1 PLC	±-	2 PLC	±-	3 PLC	±-	4 PLC	±-	ANGLES	±-
0 PLC	±-													
1 PLC	±-													
2 PLC	±-													
3 PLC	±-													
4 PLC	±-													
ANGLES	±-													
MATERIAL VER TABELA SEE TABLE		FINISH	NAME - 2 WAYS CONNECTOR ASSY											
		WEIGHT	SIZE A3											
		Customer Drawing	CAGE CODE -											
			DRAWING NO C-2819047											
			RESTRICTED TO -											
			SCALE 1:1											
			SHEET 1 OF 1											
			REV A2											