

THIS DRAWING IS UNPUBLISHED.

RELEASED FOR PUBLICATION

2022

© COPYRIGHT 2022 TE Connectivity

ALL RIGHTS RESERVED.

REVISIONS

P	LTR	DESCRIPTION	DATE	DWN	APVD
	A	INITIAL RELEASE: ECN-22-163355	16MAR2022	BN	BJ

SECTION	CONDUCTOR COMBINATIONS	CONDUCTOR COMBINATIONS	PART NO.
E	8 CU SOL	8 CU STR, 6, 8 CU SOL	2410368-5
	6 CU SOL	8 CU STR, 6, 8 CU SOL	
	8 CU STR	8 CU STR, 6, 8 CU SOL	
	4 CU SOL	8 CU STR, 8 CU SOL	
	6 CU STR	8 CU STR, 8 CU SOL	
D	4 CU SOL	6 CU STR, 4, 6 CU SOL	2410368-4
	6 CU STR	6 CU STR, 4, 6 CU SOL	
	2 CU SOL	6, 8 CU STR, 6, 8 CU SOL	
	4 CU STR	6, 8 CU STR, 6, 8 CU SOL	
C	2 CU SOL	4 CU STR, 2, 4 CU SOL	2410368-3
	4 CU STR	4 CU STR, 2, 4 CU SOL	
	1/0 CU SOL	6, 8 CU STR, 6, 8 CU SOL	
	2 CU STR	6, 8 CU STR, 6, 8 CU SOL	
B	1/0 CU SOL	4 CU STR, 2, 4 CU SOL	2410368-2
	2 CU STR	4 CU STR, 2, 4 CU SOL	
	1/0 CU STR	6, 8 CU STR, 4, 6, 8 CU SOL	
A	2 CU STR	2 CU STR, 1/0 CU SOL	2410368-1
	1/0 CU STR	2, 4 CU STR, 2 CU SOL	
WEDGE I.D.	RUN	TAP	PART NO.
	CONDUCTOR COMBINATIONS		

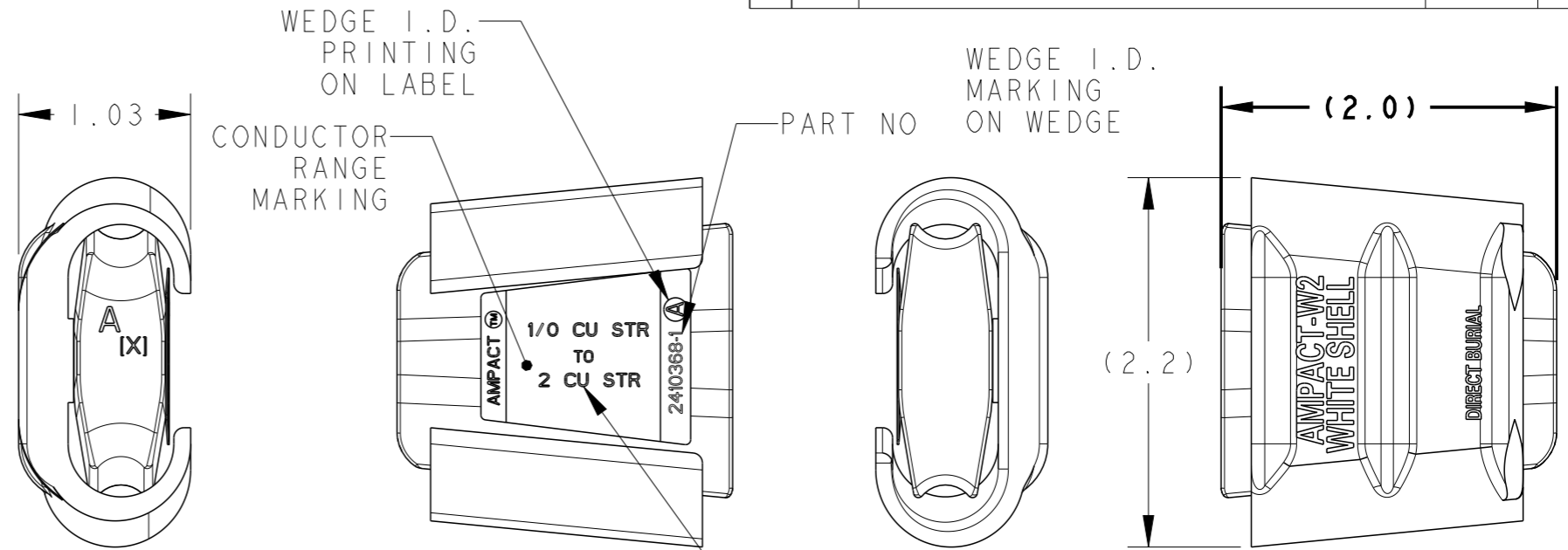

- CORRESPONDING WIRE SIZES TO RUN AND TAP SIDES ARE MARKED ON WEDGE LABEL. WEDGE I.D. MARKING ON WEDGE TO BE ORIENTED TO WEDGE I.D. PRINTING ON LABEL. (LABEL TO FACE OPEN SIDE OF C BODY).
- INHIBITOR IS APPLIED AT FACTORY TO GROOVES OF C BODY AND WEDGE.
- DIMENSIONS ARE FOR REFERENCE ONLY
- USE WHITE CARTRIDGE PART NO: 69338-5 WITH AMPACT TOOL PART NO: 69437.

A/R					INHIBITOR, SYNTHETIC	3	
1	-	-	-	-	#6-#8	COPPER WEDGE WITH LABEL	2
-	1	-	-	-	#4-#6		
-	-	1	-	-	#2-#6		
-	-	-	1	-	1/0-#6		
-	-	-	-	1	1/0-#2	C BODY, CAST COPPER ALLOY	1
1	1	1	1	1			
-5	-4	-3	-2	-1	DESCRIPTION		ITEM NO
QTY					PARTS LIST		

THIS DRAWING IS A CONTROLLED DOCUMENT.

DWN BN.ARUN 16MAR2022

CHK J.GUPPY 16MAR2022

APVD B.JOHNSON 16MAR2022

PRODUCT SPEC

APPLICATION SPEC

WEIGHT -

CUSTOMER DRAWING

SCALE NTS

SHEET 1 OF 1

REV A

TE Connectivity

WEDGE TAP CONNECTOR, COPPER, SMALL, WHITE CODED, AMPACT, 8 AWG SOL-1/0 AWG STD STR CONDUCTORS

SIZE A3

CAGE CODE -

DRAWING NO C-2410368

RESTRICTED TO -