

P	LTR	DESCRIPTION	DATE	DWN	APVD
B	REVISED (ECR-22-155113)		11OCT2022	JH	GC

TABLE-1 RECOMMENDED MATING LENGTH

- REAR BODY ASSY : 2327435-2, 2351723-2, 2364122-2, 2379429-2
- FLOATING HEADER ASSY : 2327462-1

- * RECOMMENDED PCB LAYOUT
- GENERAL TOLERANCE : ±0.05mm

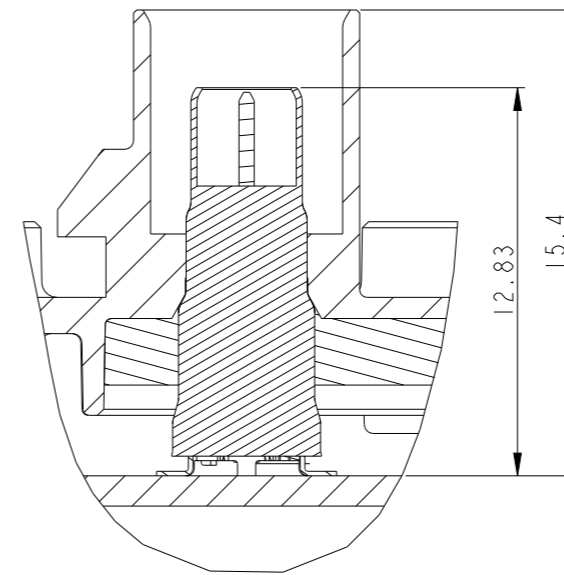
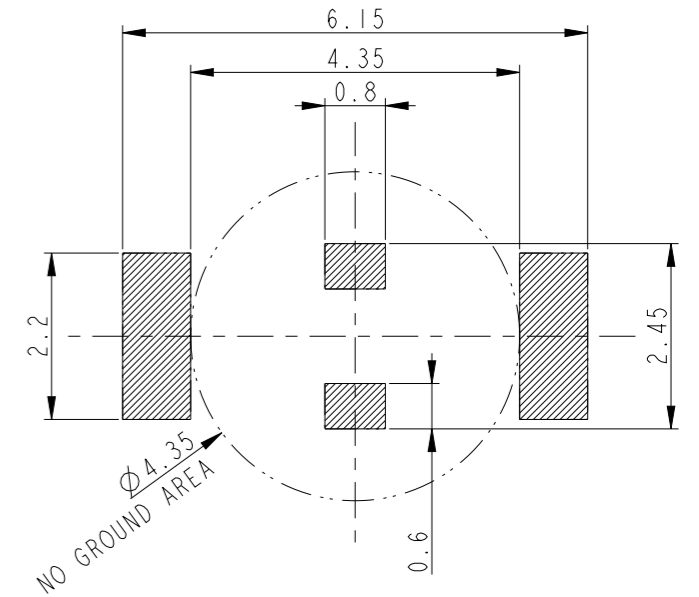

- REAR BODY ASSY : 2410950-1
- FLOATING HEADER ASSY : 2327462-1

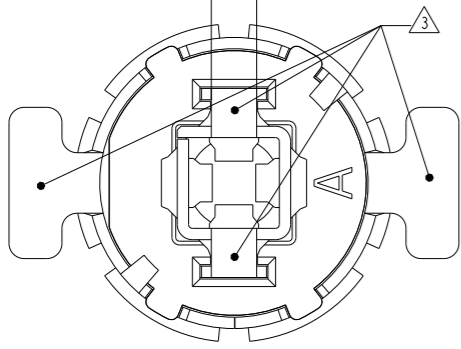
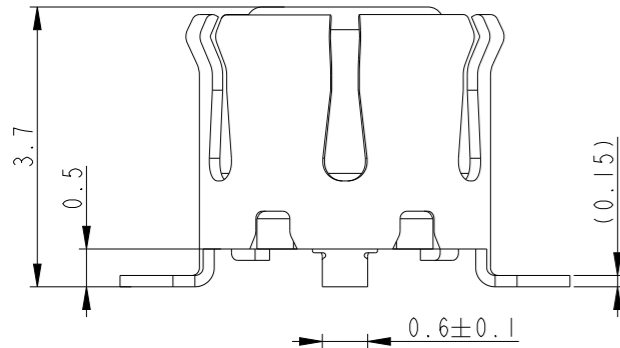
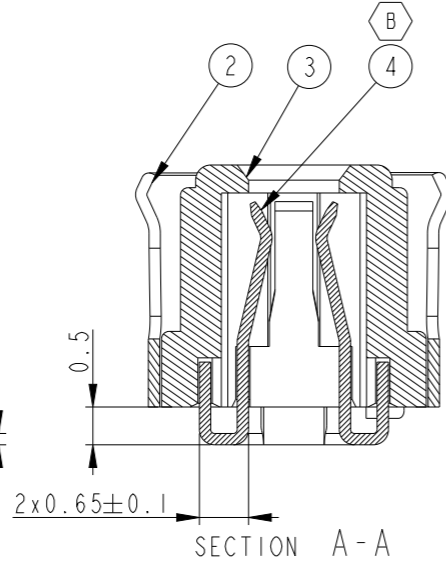
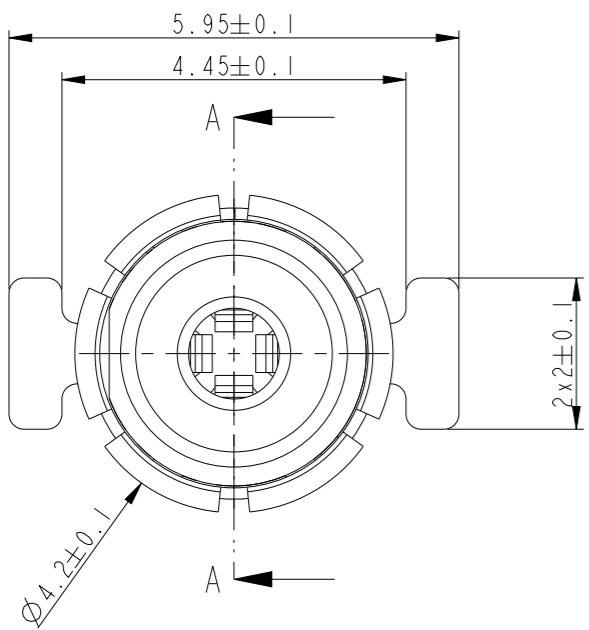
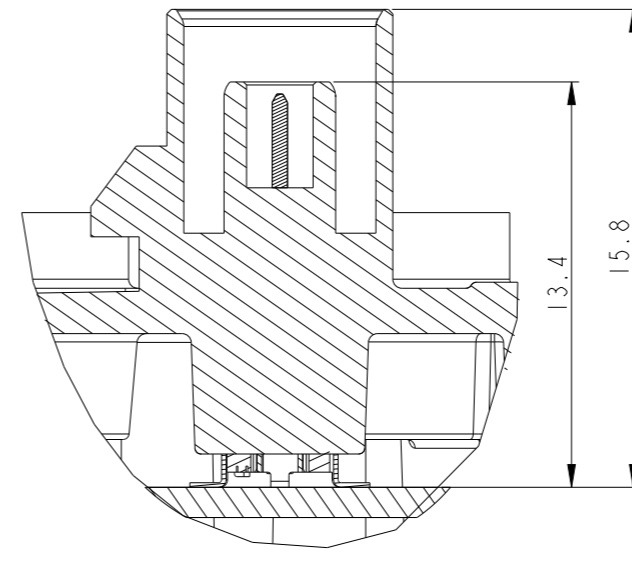

* PACKAGING WITH SUCTION CAP

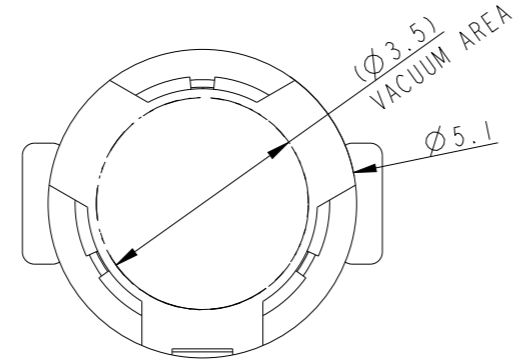

- NOTE
- 1. GENERAL TOLERANCE : ±0.3
- 2. P/N OF REAR BODY ASS'Y MATED WITH FLOATING HEADER : SEE TABLE-1
- 3. COPLANAR ALLOWS UP MAX. 0.1mm
- 4. MEET THE ES91500-03 SPECIFICATION.
- 5. MEET THE ES91500-02 SPECIFICATION.
- 6. FLOATING TOLERANCE X,Y=±0.2, Z=±0.5
- 7. PACKAGING INFORMATION

THIS DRAWING IS A CONTROLLED DOCUMENT.

DIMENSIONS:	TOLERANCES UNLESS OTHERWISE SPECIFIED:
mm	0 PLC ±
	1 PLC ±0.1
	2 PLC ±0.01
	3 PLC ±0.001
	4 PLC ±0.0001
	ANGLES ±
MATERIAL	FINISH
-	-
-	-

DWN	JH KIM
CHK	GC KWON
APVD	GC KWON
PRODUCT SPEC	108-61431
APPLICATION SPEC	-
WEIGHT	-
CUSTOMER DRAWING	-

NO.	COLOR/FINISH	DESCRIPTION	Q'TY
4	GOLD PLATING	SOCKET	1
3	NATURAL	HEADER DIELECTRIC	1
2	POST-TIN	OUT SHELL	1
1	NATURAL	SUCTION CAP	1



Floating Header Ass'y

SIZE	CAGE CODE	DRAWING NO	RESTRICTED TO
A3	00779	C-2327462	-
SCALE	SHEET	OF	REV
10:1	1	2	B

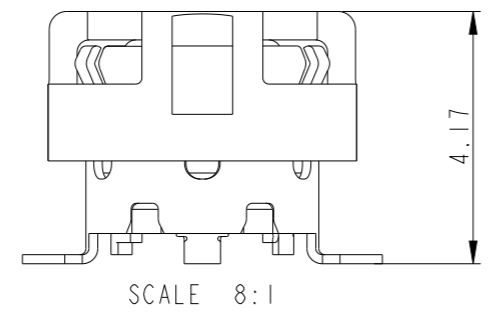
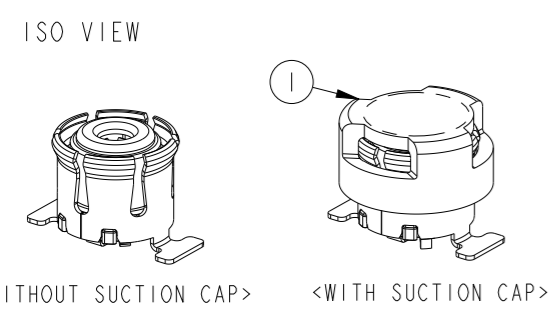

P	LTR	DESCRIPTION	DATE	DWN	APVD
		SEE SHEET 1			

A1

7 PACKAGING INFORMATION

TYPE	TAPE WIDTH	DEVICE CAVITY PITCH	REEL SIZE	QTY PER REEL
TAPE&REEL	16	12	380	1500

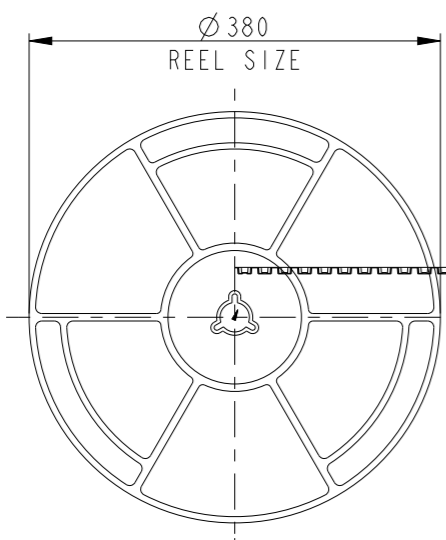
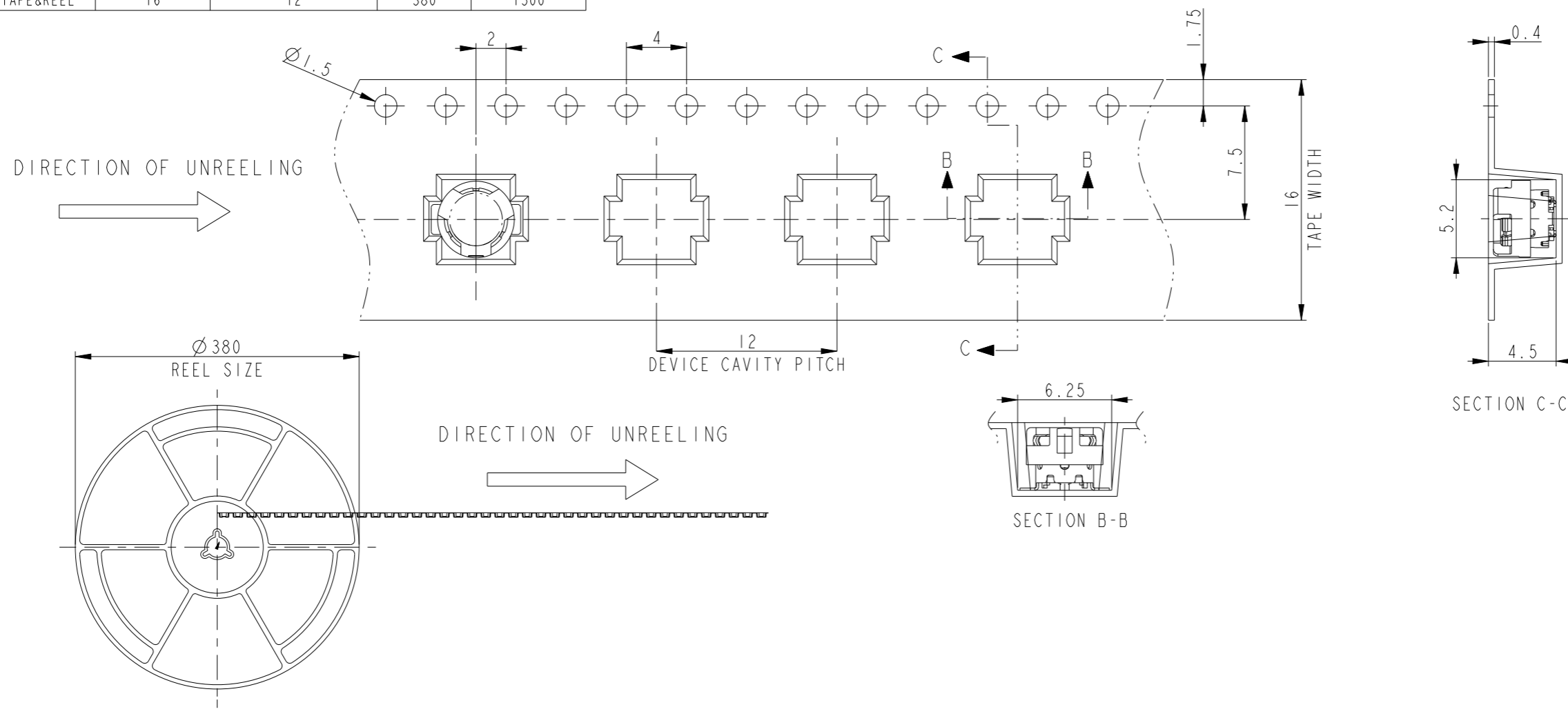

THIS DRAWING IS A CONTROLLED DOCUMENT.

DIMENSIONS:
mm

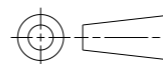

TOLERANCES UNLESS OTHERWISE SPECIFIED:

0 PLC	±
1 PLC	±0.1
2 PLC	±0.01
3 PLC	±0.001
4 PLC	±0.0001
ANGLES	±

MATERIAL

FINISH

DWN	JH KIM
CHK	GC KWON
APVD	GC KWON
PRODUCT SPEC	108-61431
APPLICATION SPEC	-
WEIGHT	-



NAME	-		
NAME	Floating Header Ass'y		
SIZE	CAGE CODE	DRAWING NO	RESTRICTED TO
A3	00779	C-2327462	-

CUSTOMER DRAWING

SCALE 10:1

SHEET 2 OF 2

REV B