

REVOLUTIONS		DATE	BY	APPD
A2	ECR-19-001644	07FEB2019	AB	AB
A3	ECR-20-002001	09FEB2020	SK	AB
A4	ECR-20-004573	27MAR2020	KK	AB
A5	PCN-22-134778 (ADDED 1-2305987-X)	28MAR2022	KMD	GILC

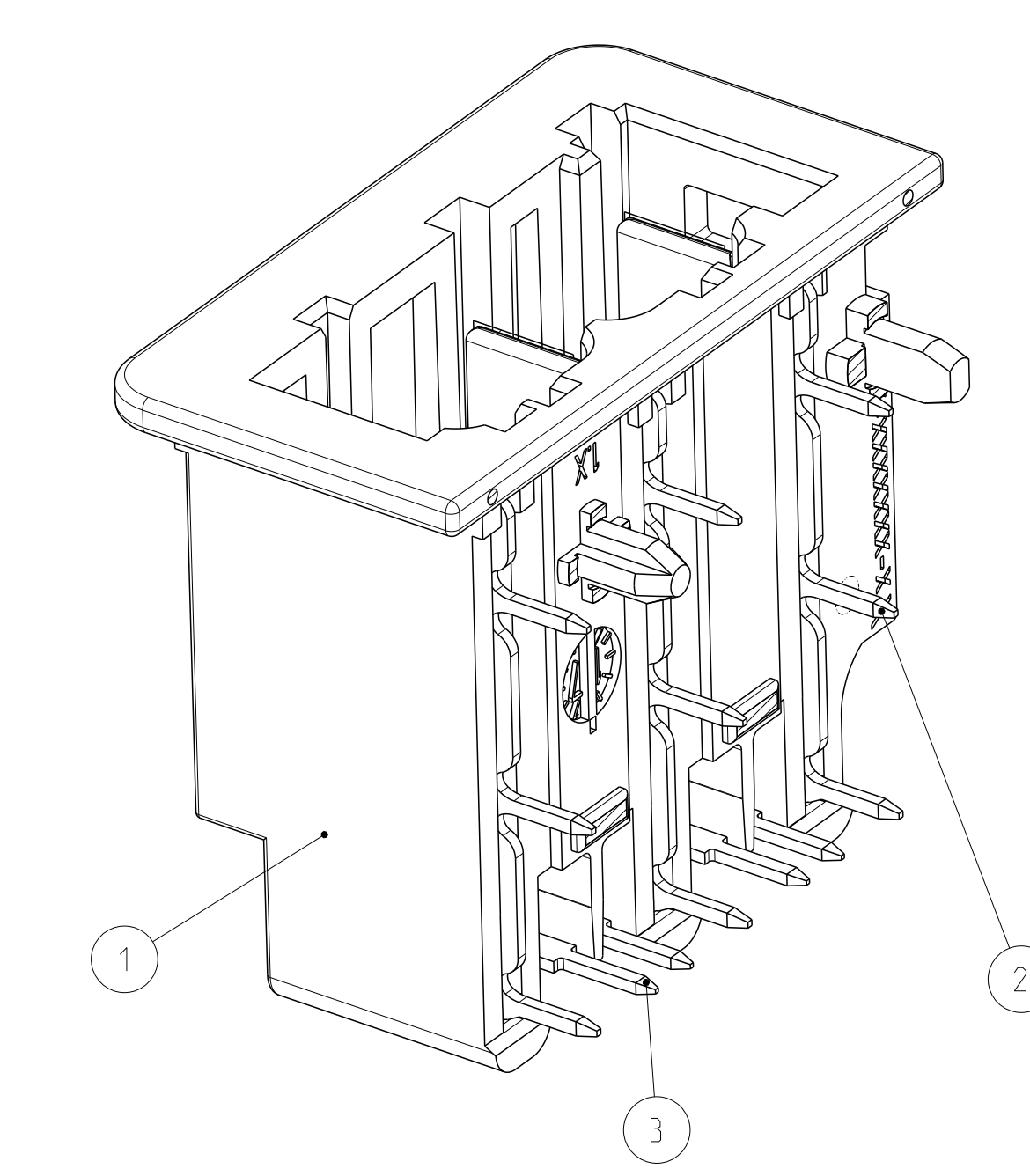

- NOTES
Bemerkungen
- 1 PRESS OUT FORCE FOR NANOMQS CONTACT >15N WITH FEED RATE 25mm/min
Kontaktausdrueckkraft fuer NanoMQS Kontakt >15N mit Vorschubgeschwindigkeit 25mm/min
 - 2 INTERFACES AND COLOUR ACC. TO 208-18012, REV. A3, 24JAN2020
Schnittstellen und Farbe nach 208-18012, Rev.A1 vom 24JAN2020
 - 3 SOLDERING PROCESS: LEAD-FREE REFLOW SOLDERING IN REFERENCE TO JEDEC J-STD-020D
Loetprozess: Bleifreies Loeten in Anlehnung an die JEDEC J-STD-020D
 - 4 TOLERANCES ACC. TO DIN EN ISO 8015, DIN EN ISO 14405-1
GENERAL TOL. ACC. TO DIN 16742 TGS, EXCEPT ANGLE DIM. (SEE TITLE BLOCK)
Tolerierung nach DIN EN ISO 8015, DIN EN ISO 14405-1
Allgemeintoleranzen nach DIN 16742 TGS, ausser Winkelmasse (siehe Schriftkopf)
 - 5 PACKAGING IN TAPE & REEL ACC. TO V2305987
Verpackung in Tape & Reel nach V2305987
 - 6 CONTACT SURFACE SOLDER SIDE 3-8µm Sn OVER 1-2.5µm Ni
Kontaktoberflaeche Loetseitig 3-8µm Sn ueber 1-2.5µm Ni
 - 7 FOR MISSING DIMENSION SEE CAD-MODEL 2305987-X, REV. A
Fehlende Masse sind dem CAD-Model 2305987-X, Rev. A zu entnehmen
 - 8 GOOD PART MARKING PUNCH MARKED
Gutteilmarkierung Koernerpunkt
 - 9 ELECTRICAL 100% FINAL INSPECTION FOR CONTINUITY AND SHORT CIRCUIT
AS WELL AS EXISTENCE OF ALL CONTACTS
Elektrische 100% Endpruefung auf Durchgang und Kurzschluss,
sowie das Vorhandensein aller Kontakte
 - 10 VACUUM GRIP AREA FREE OF BURR AND EJECTOR PINS
Ansaugflaeche frei von Grat und Auswerferstiften
 - 11 -
 - 12 HEADER FULFILL RF-REQUIREMENTS UP TO 1GHz ACC. TE SPEC. 108-94509, ALSO MANDATORY IS
A PCB COPPER LAYER ACC. TO TE SPEC. 114-94448
Der Header erfuellt die RF-Anforderungen bis zu 1 GHz nach TE Spez. 108-94509. Ebenfalls
notwendig ist eine Leiterplatten Kupferschicht nach TE Spec. 114-94448
 - 13 HEADER FULFILL RF-REQUIREMENTS UP TO 100 Mhz ACC. TE SPEC 108-94444
Der Header erfuellt die RF-Anforderungen bis zu 100MHz nach TE Spez.108-94444
 - 14 APPLICATION SPECIFICATION ACC. TO 114-94448
Anwendungsspezifikation TE Spez. 114-94448
 - 15 Corresponding mating connector see drawing C-2305974 or C-2307961 and Product Spec. 108-94568
Passender Gegenstecker siehe Zeichnung C-2305974 oder C-2307961 und Produkt spez. 108-94568
 - 16 REFERENCE POINTS A1-A4, B1-B2, D1-D4, E1-E2 TO BE TAKEN IN SHOWN HEIGHT
Bezugspunkte A1-A4, B1-B2, D1-D4, E1-E2 sind in angegebener Hoehe zu ermitteln
 - 17 REFERENCE POINTS A5-AB, B3-B4 TO BE TAKEN IN SHOWN HEIGHT
Bezugspunkte A5-AB, B3-B4 sind in angegebener Hoehe zu ermitteln
 - 18 REFERENCE POINTS D5-DB, E3-E4 TO BE TAKEN IN SHOWN HEIGHT
Bezugspunkte D5-DB, E3-E4 sind in angegebener Hoehe zu ermitteln

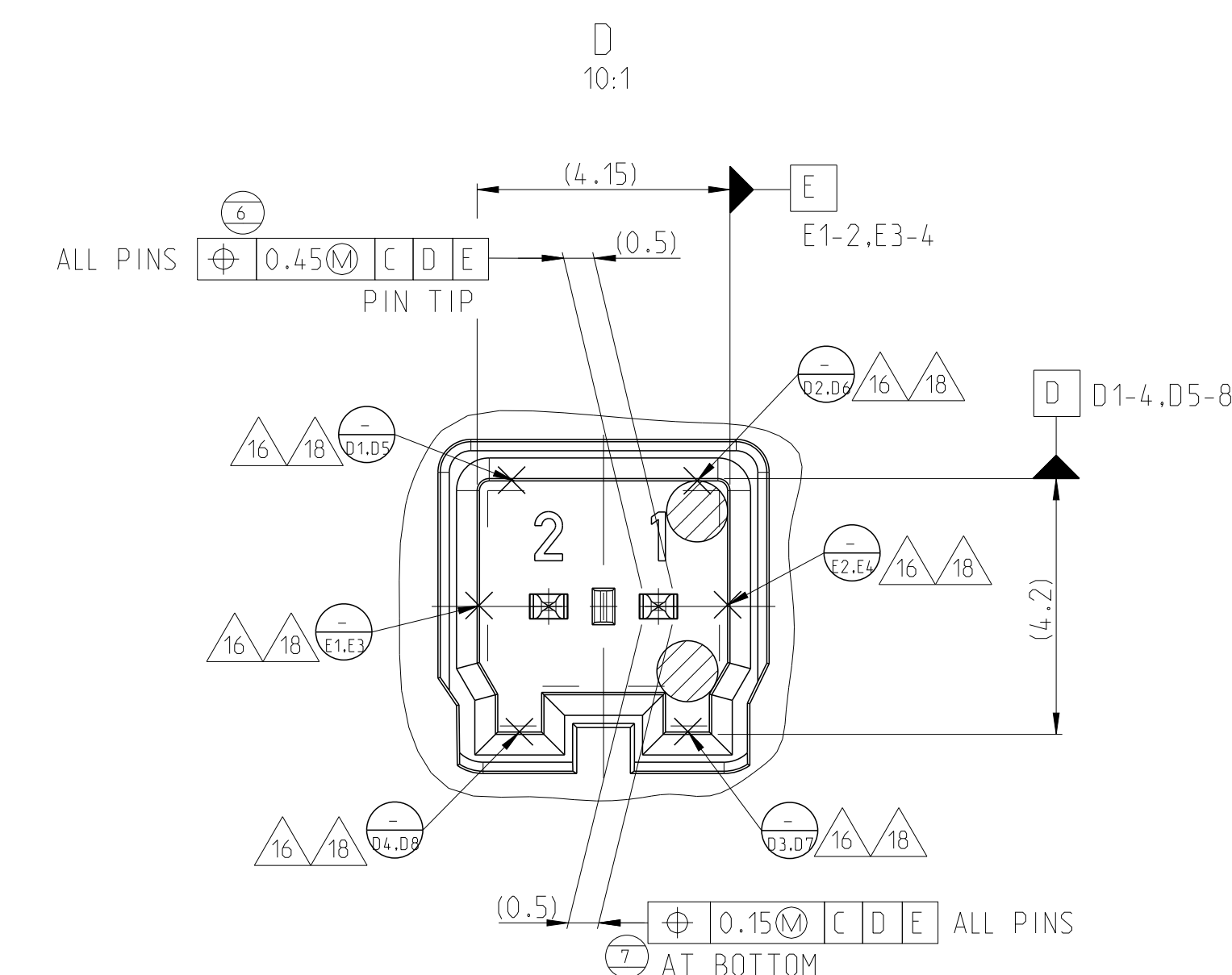
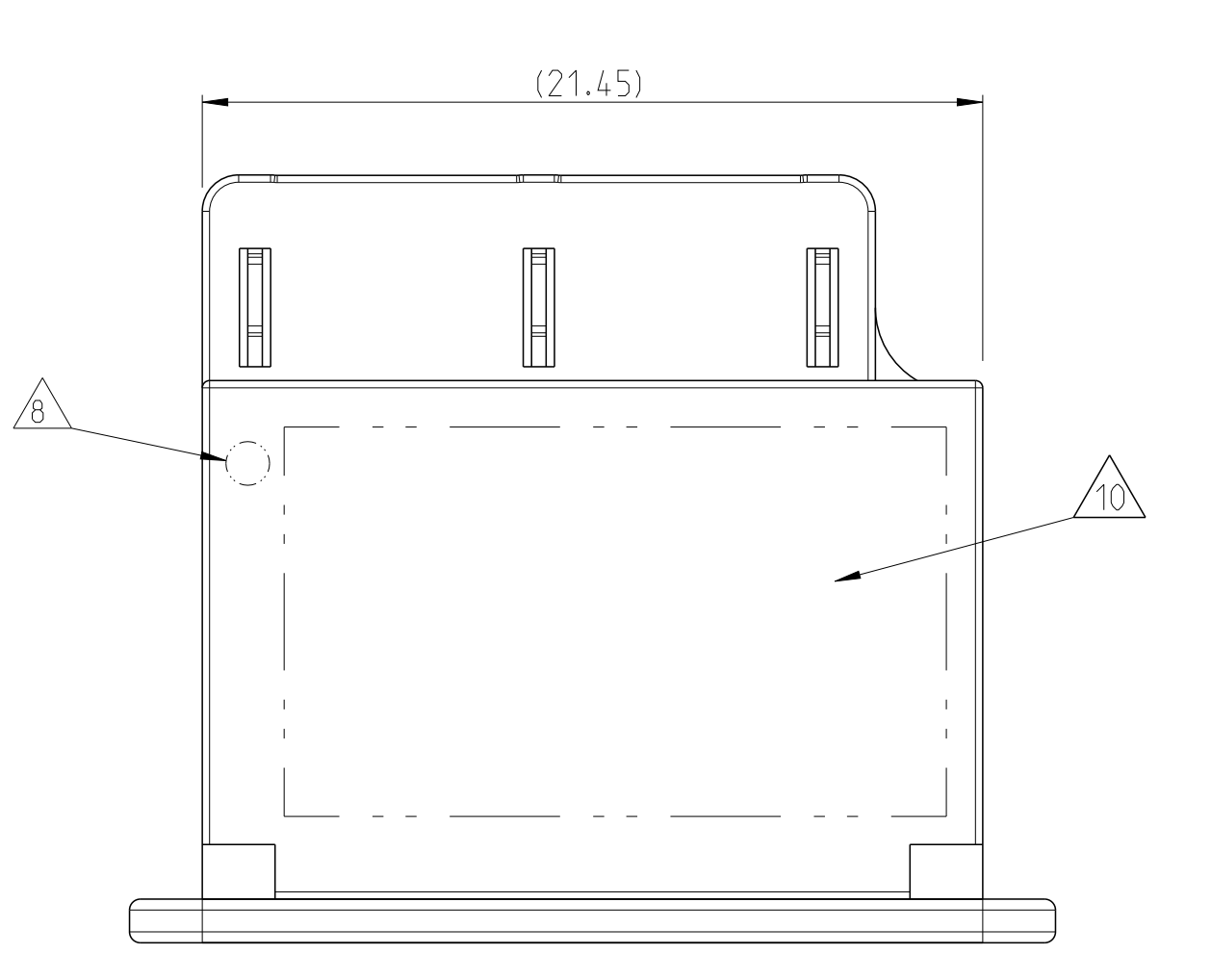
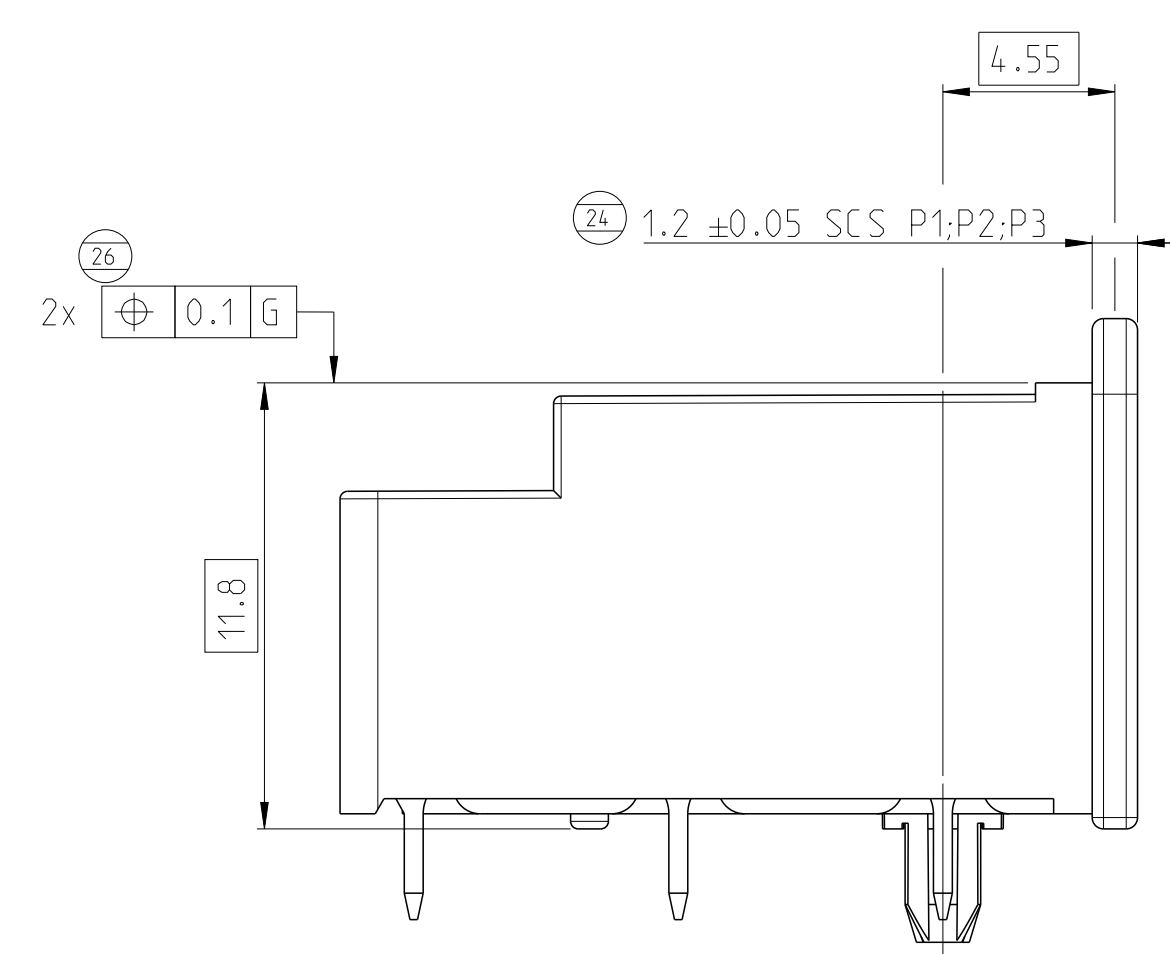
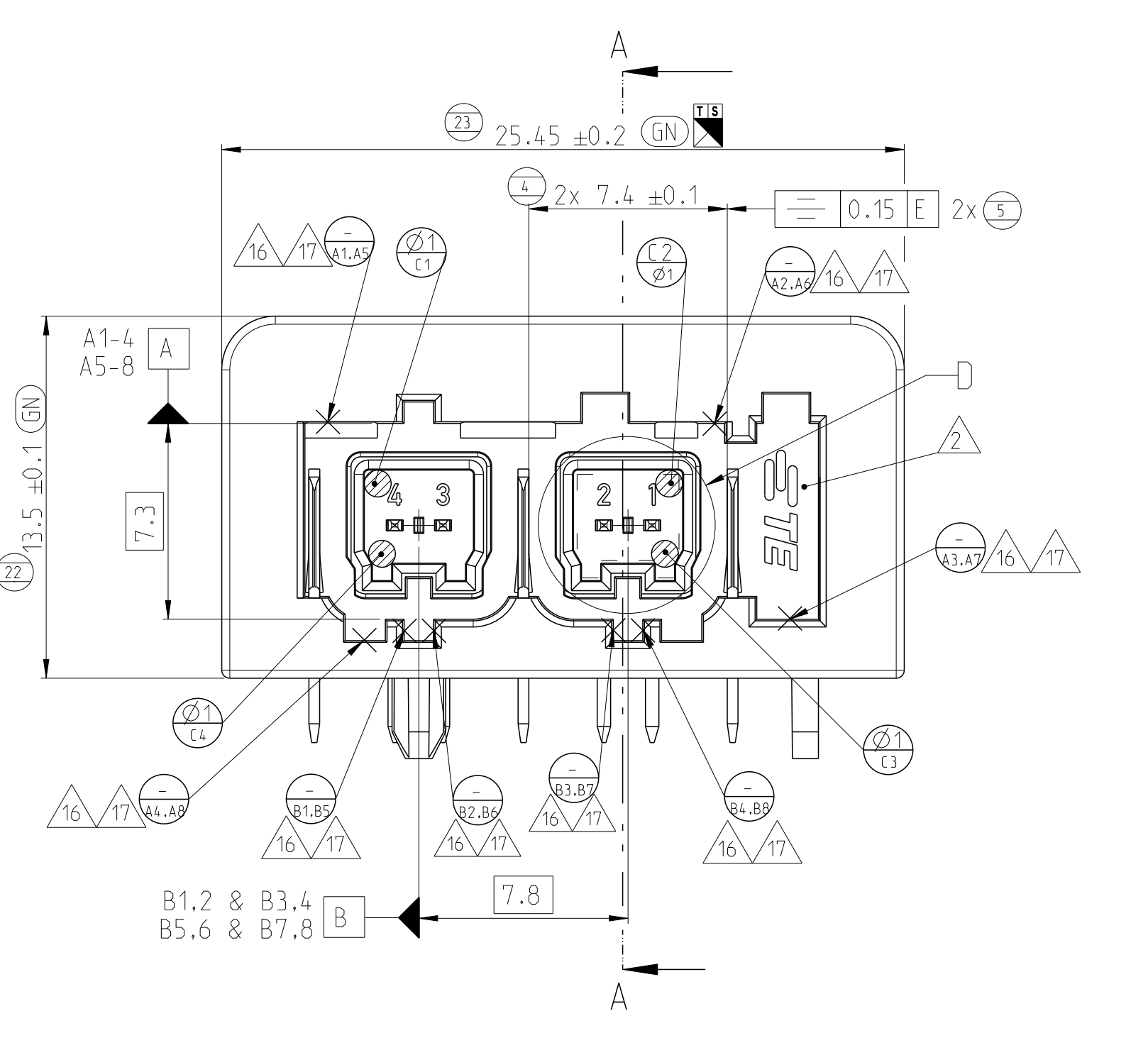
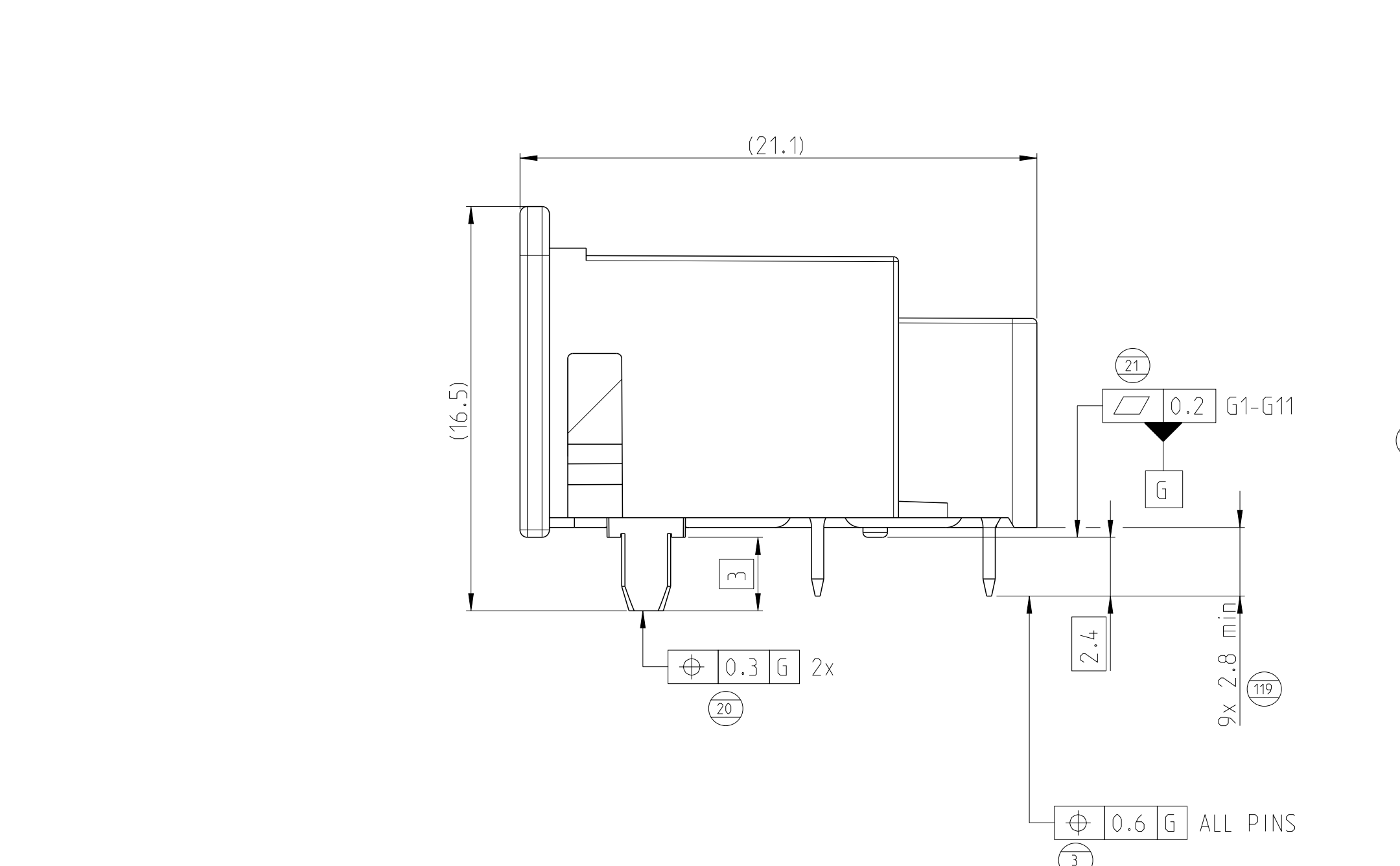
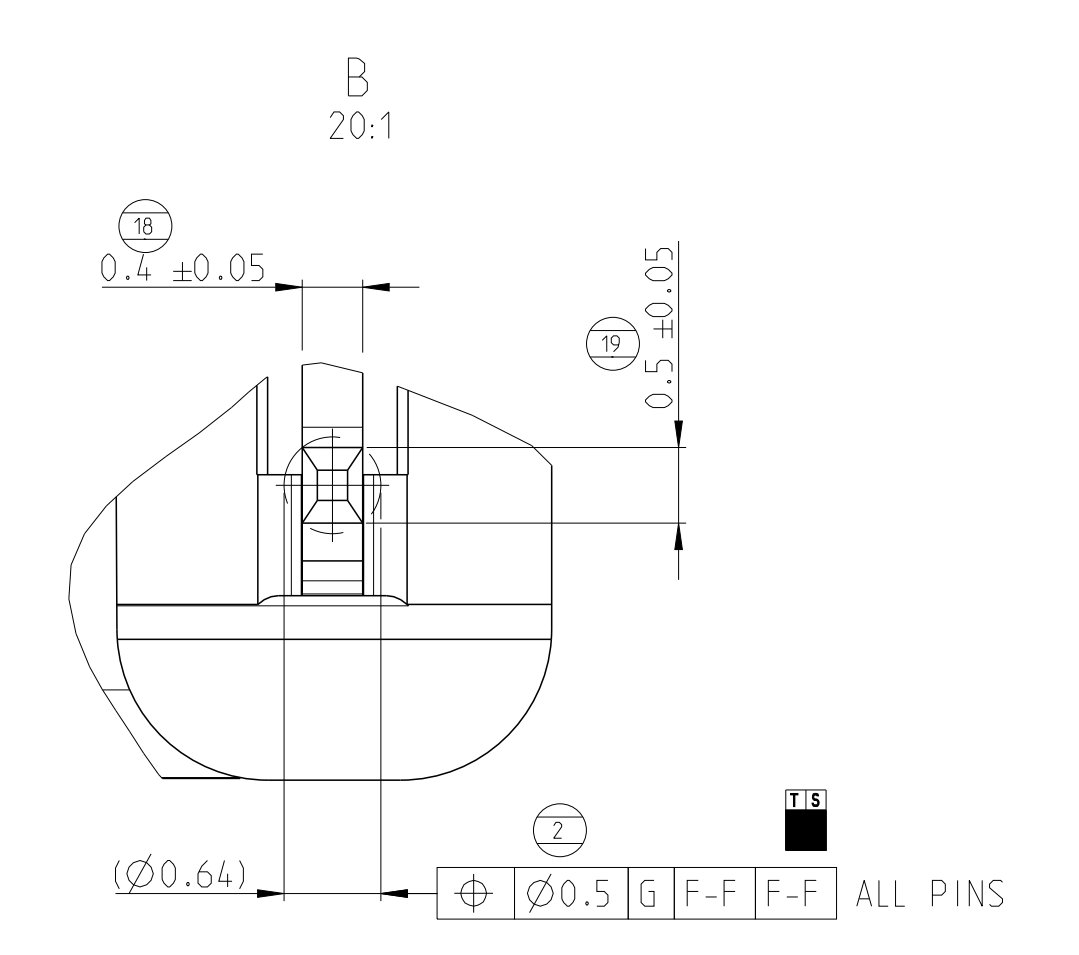
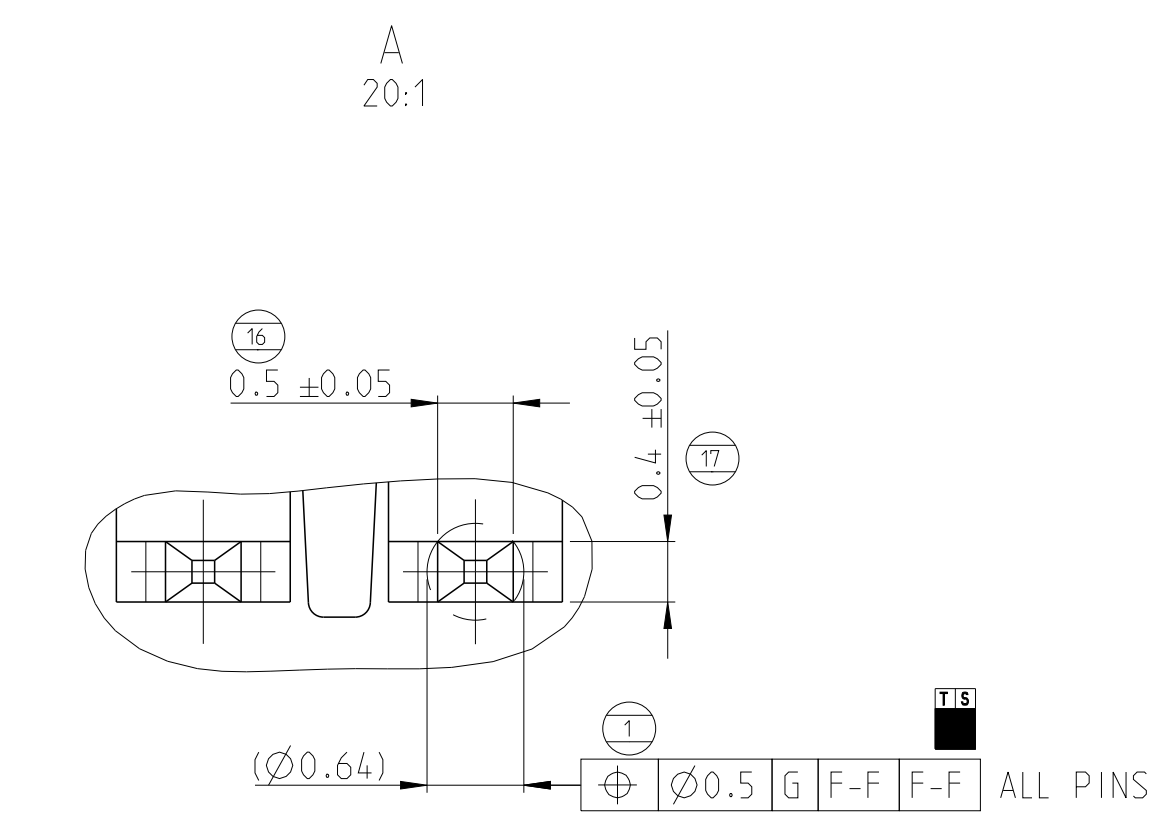
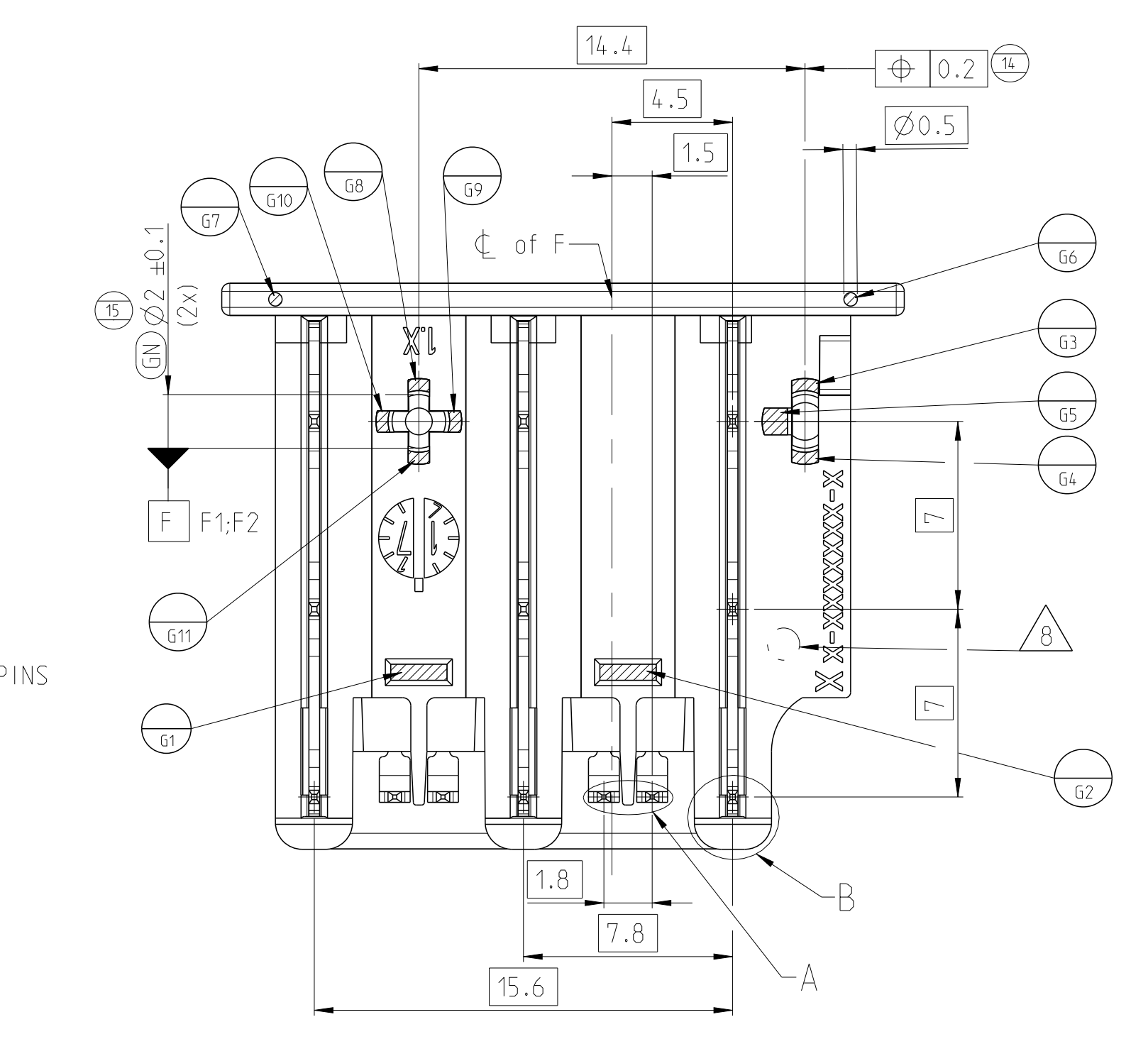
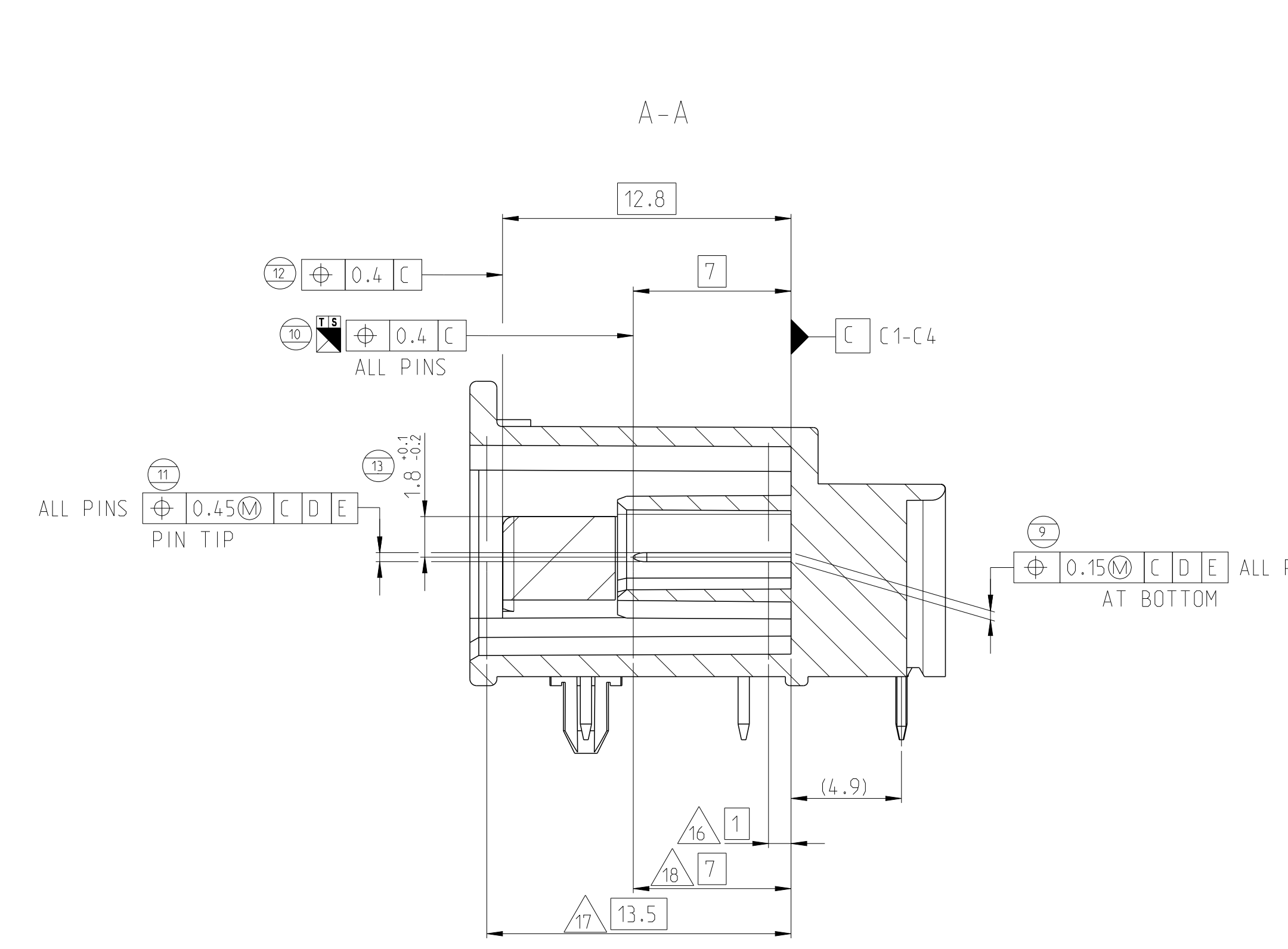
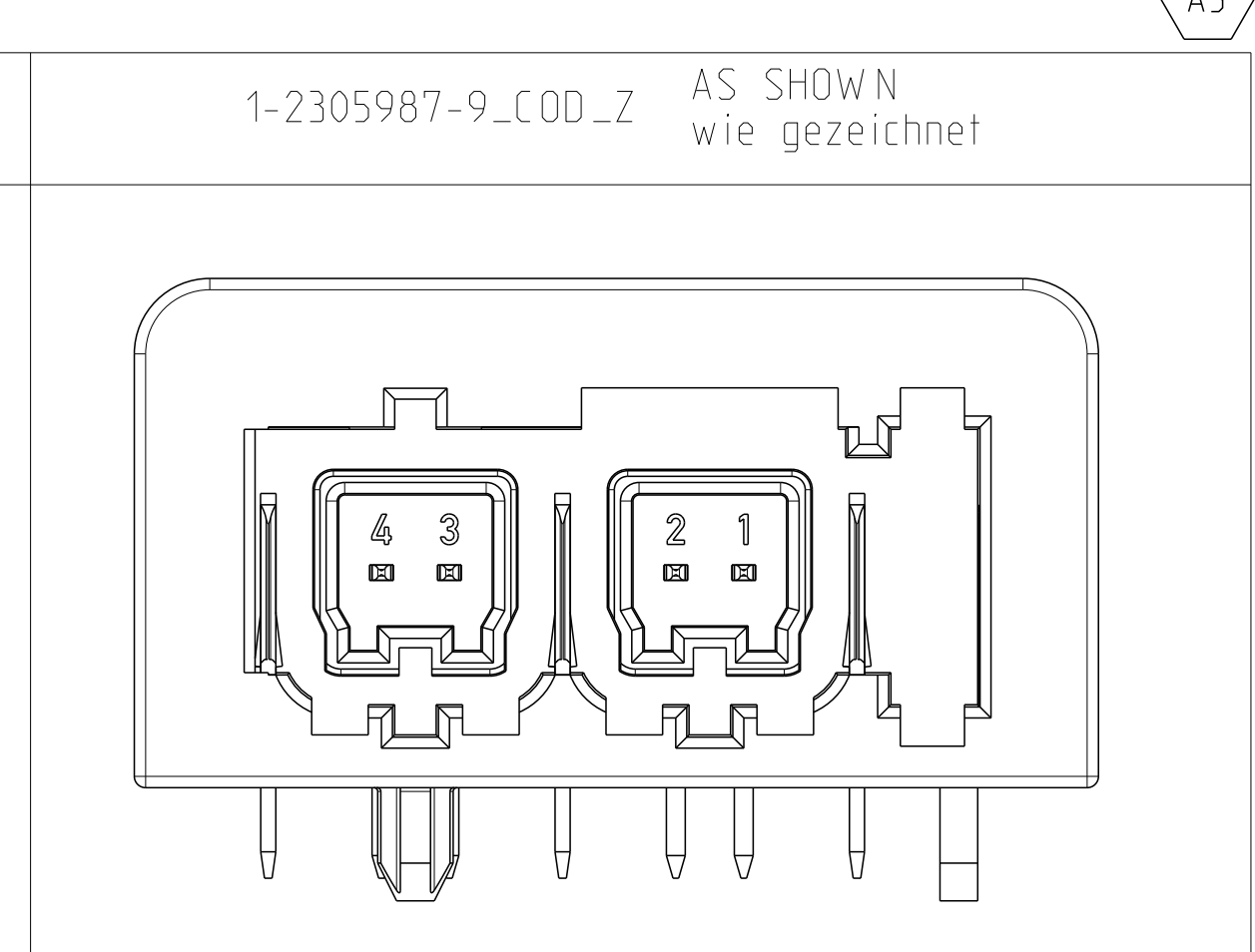
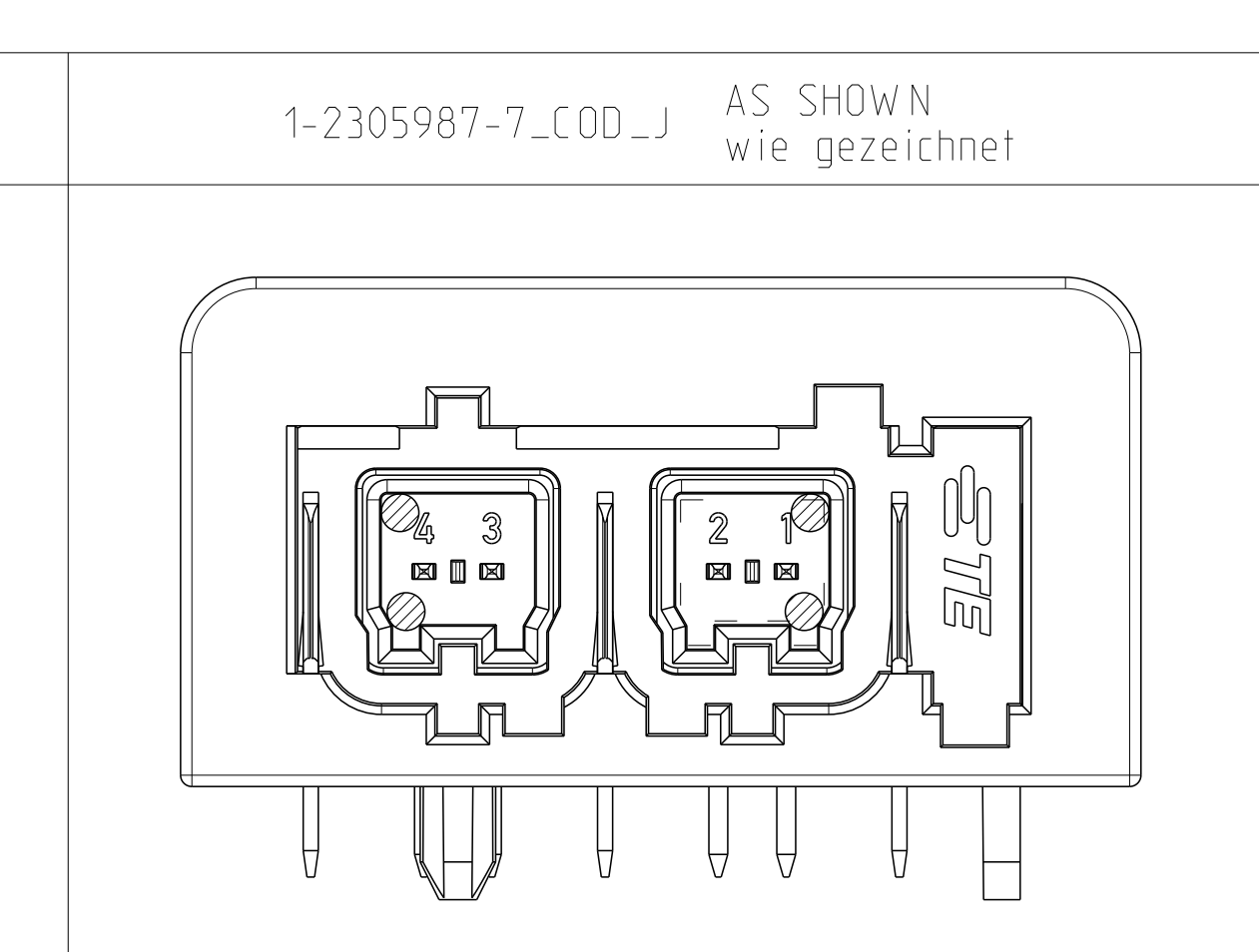
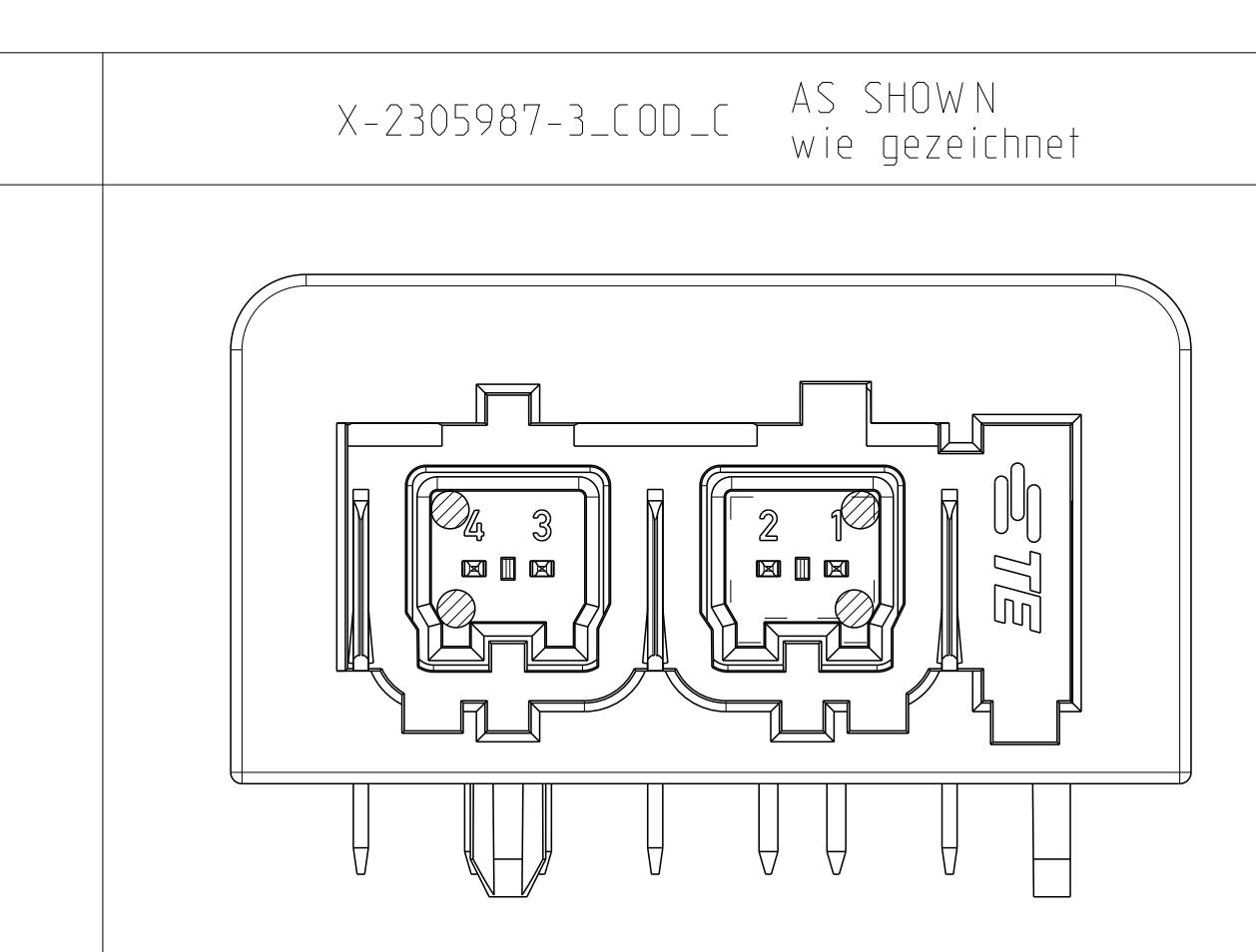
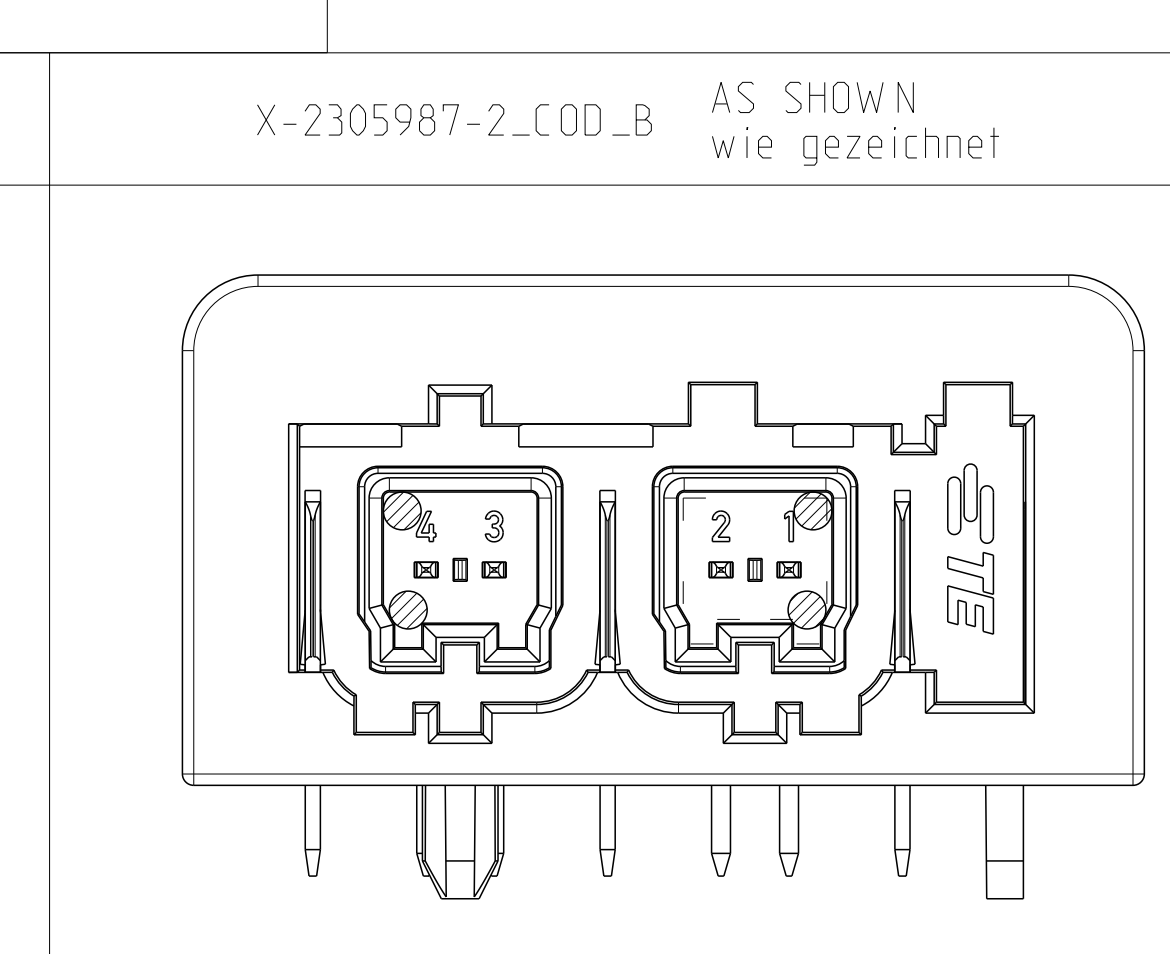
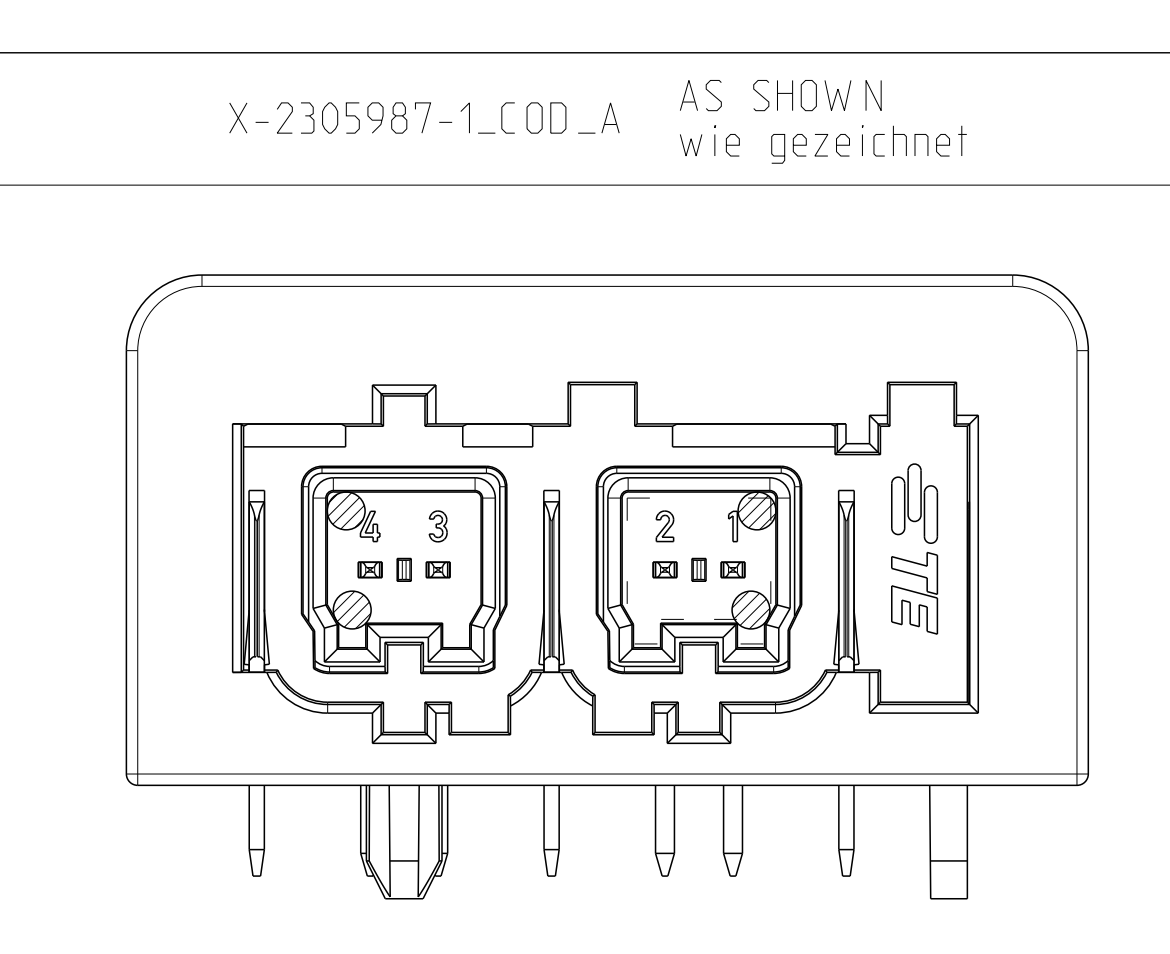
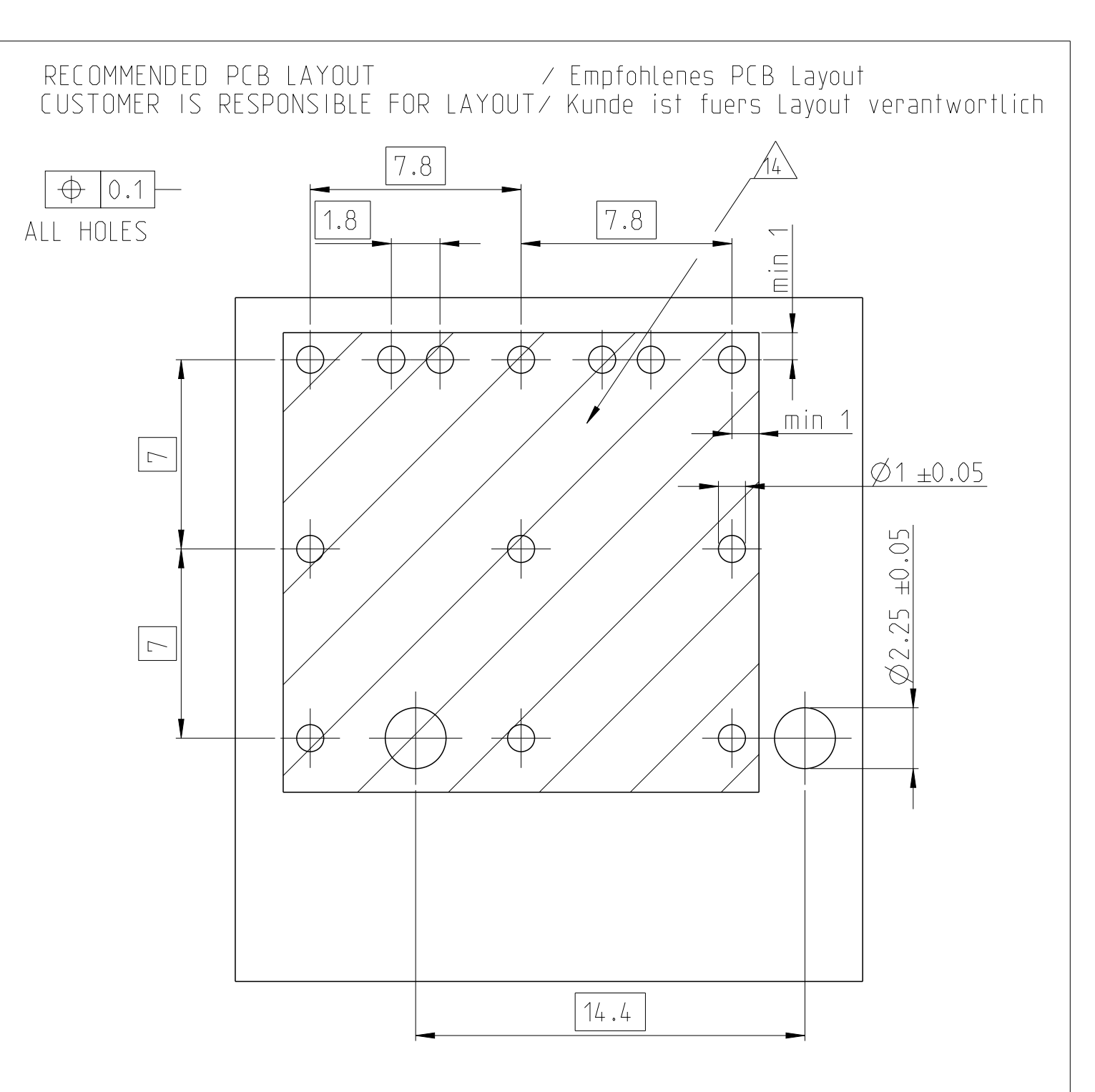

2305987-2 COD. B AS SHOWN wie gezeichnet

TE ASSY NO.	WEIGHT [g] THEORETICAL	COLOUR	CODING	REV	QTY.	DESCRIPTION	MATERIAL	POS.
9-2305987-9	4.53	WATER BLUE	Z	A	4	Nano MQS TAB 90° Sn	Cu-Alloy	3
					3	Shield	Cu-Alloy	2
					1	2 Port 90° HSG COD.Z	PA4T-GF30	1
PILOT								
1-2305987-9	4.46	WATER BLUE	Z	A	4	Nano MQS TAB 90° Sn	Cu-Alloy	3
					3	Shield	Cu-Alloy	2
					1	2 Port 90° HSG COD.Z	PA10T-GF30	1
1-2305987-7	4.53	BEIGE	J	A	4	Nano MQS TAB 90° Sn	Cu-Alloy	3
					1	2 Port 90° HSG COD.J	PA10T-GF30	1
1-2305987-3	4.59	BLUE	C	A	4	Nano MQS TAB 90° Sn	Cu-Alloy	3
					1	2 Port 90° HSG COD.C	PA10T-GF30	1
1-2305987-2	4.6	WHITE	B	A	4	Nano MQS TAB 90° Sn	Cu-Alloy	3
					1	2 Port 90° HSG COD.B	PA10T-GF30	1
1-2305987-1	4.58	BLACK	A	A	4	Nano MQS TAB 90° Sn	Cu-Alloy	3
					1	2 Port 90° HSG COD.A	PA10T-GF30	1
2305987-3	4.59	BLUE	C	A	4	Nano MQS TAB 90° Sn	Cu-Alloy	3
					1	2 Port 90° HSG COD.C	PA4T-GF30	1
2305987-2	4.6	WHITE	B	A	4	Nano MQS TAB 90° Sn	Cu-Alloy	3
					1	2 Port 90° HSG COD.B	PA4T-GF30	1
2305987-1	4.58	BLACK	A	A	4	Nano MQS TAB 90° Sn	Cu-Alloy	3
					1	2 Port 90° HSG COD.A	PA4T-GF30	1

100% Inspection / 100% Pruefung
 Cm<= 1.67
 Cm<= 1.67

ROUTINE INSPECTION / Routine Pruefung

THIS DRAWING IS A CONTROLLED DOCUMENT.
 DIMENSIONS: (mm)
 MATERIAL: SEE TABLE
 FINISH: SEE NOTES

TE Connectivity
 2 PORT HEADER ASSY
 2 Port Header ASSY

SCALE: 5:1
 SHEET: 1 of 2
 REV: A5

REVISIONS			
NO.	DATE	DESCRIPTION	BY
1		SEE SHEET 1	

MATED WITH CONNECTOR

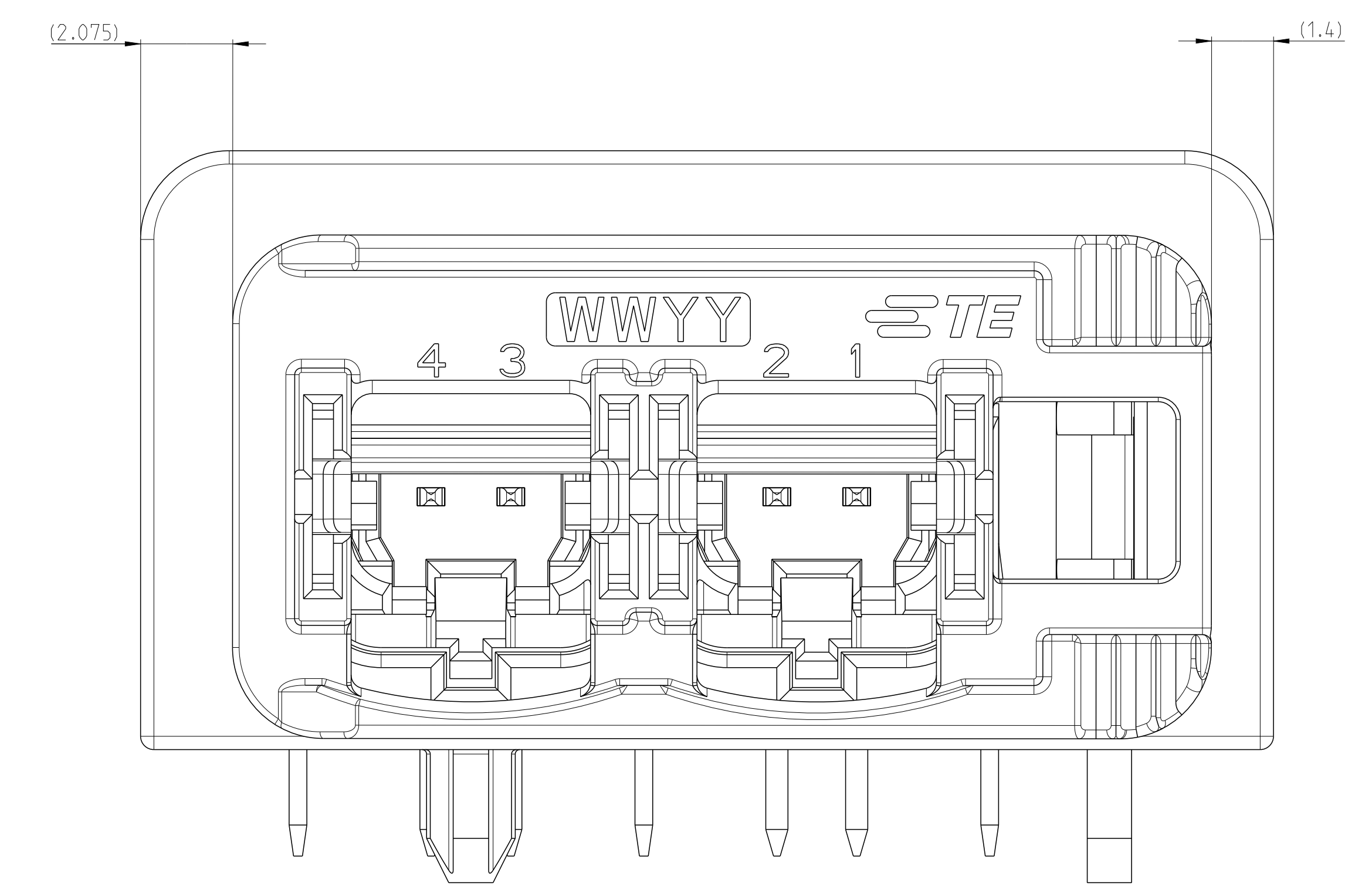
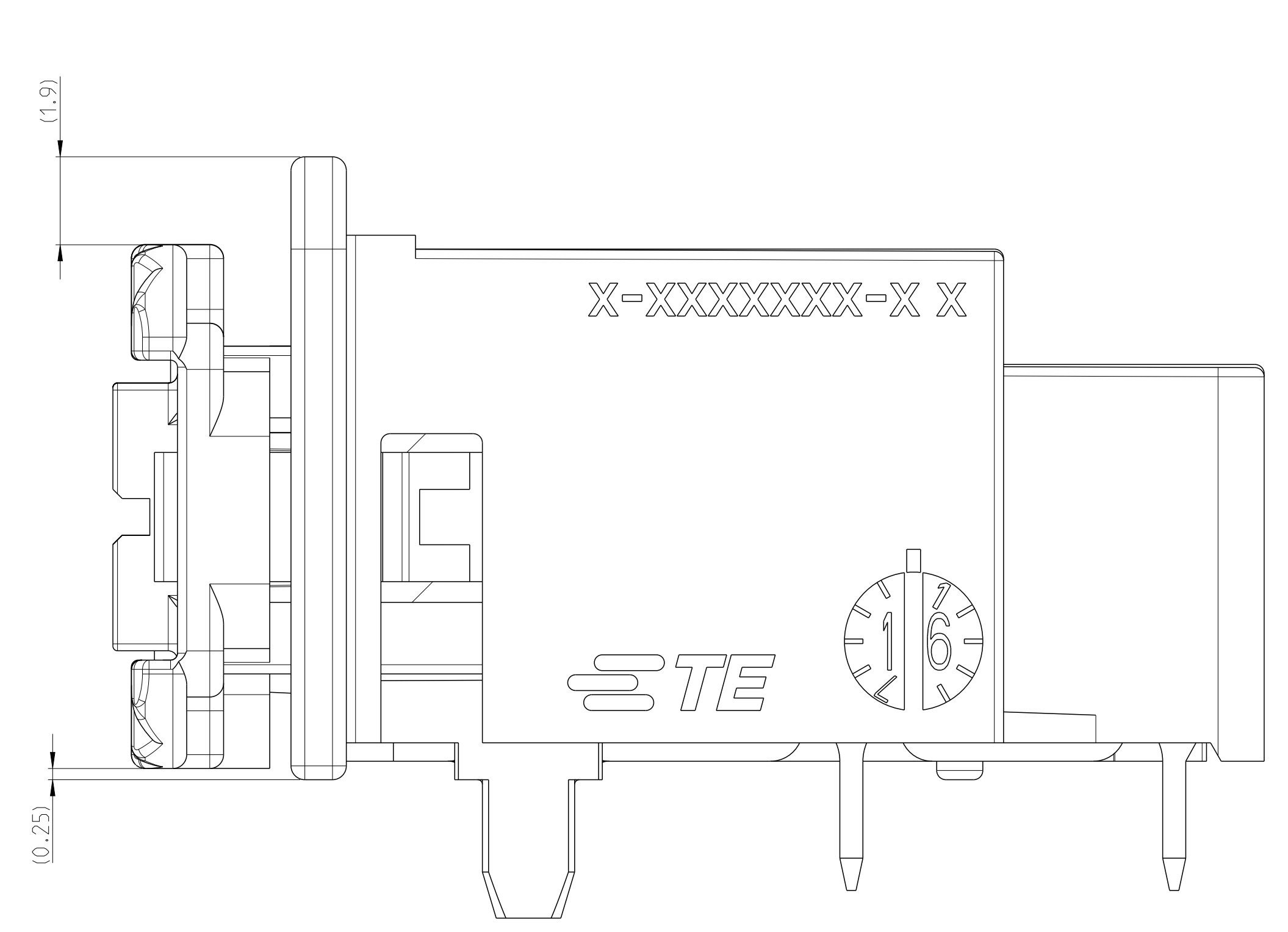

POSSIBLE FIXTURE OF HEADER

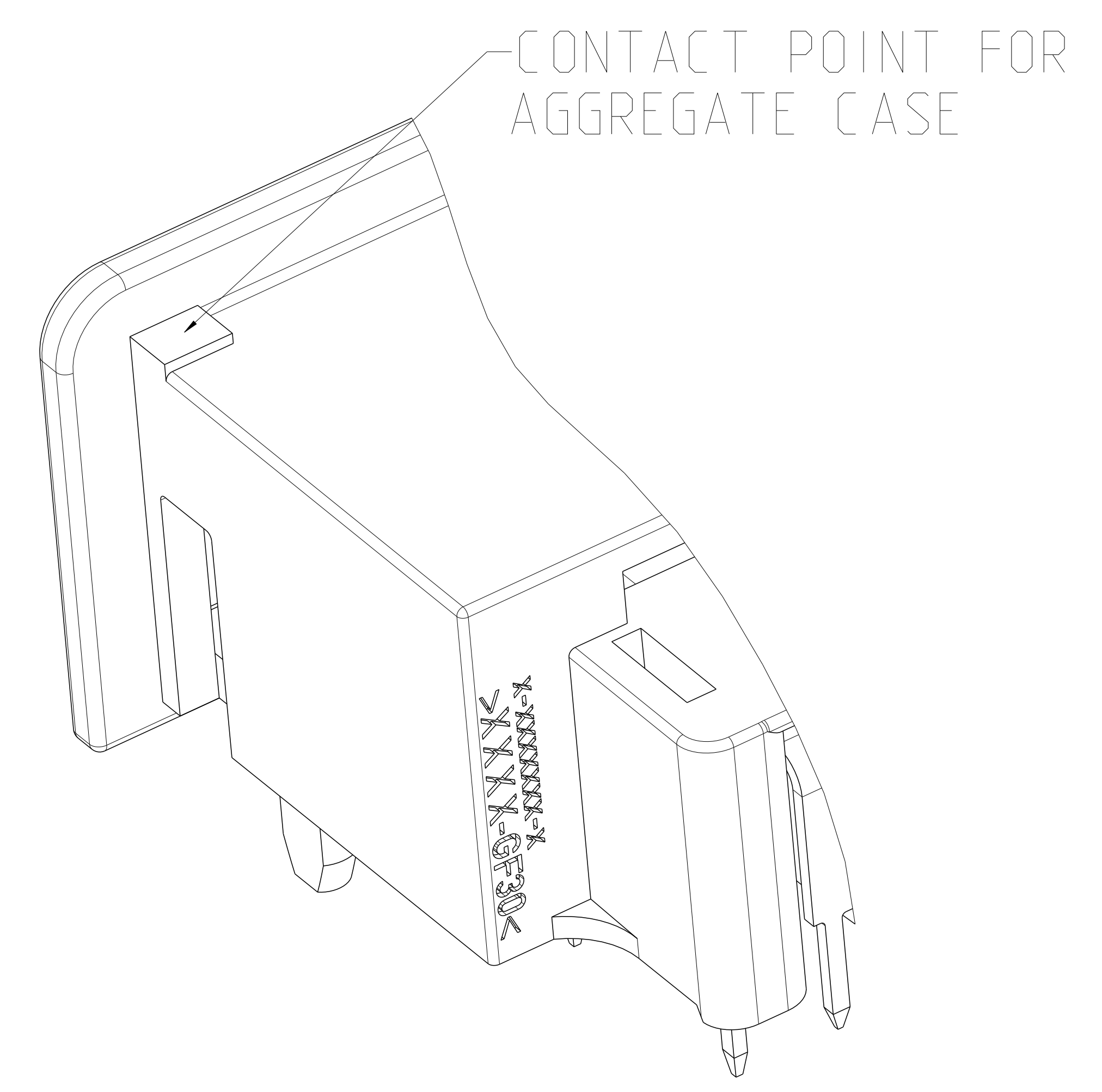

PROPOSAL CASE

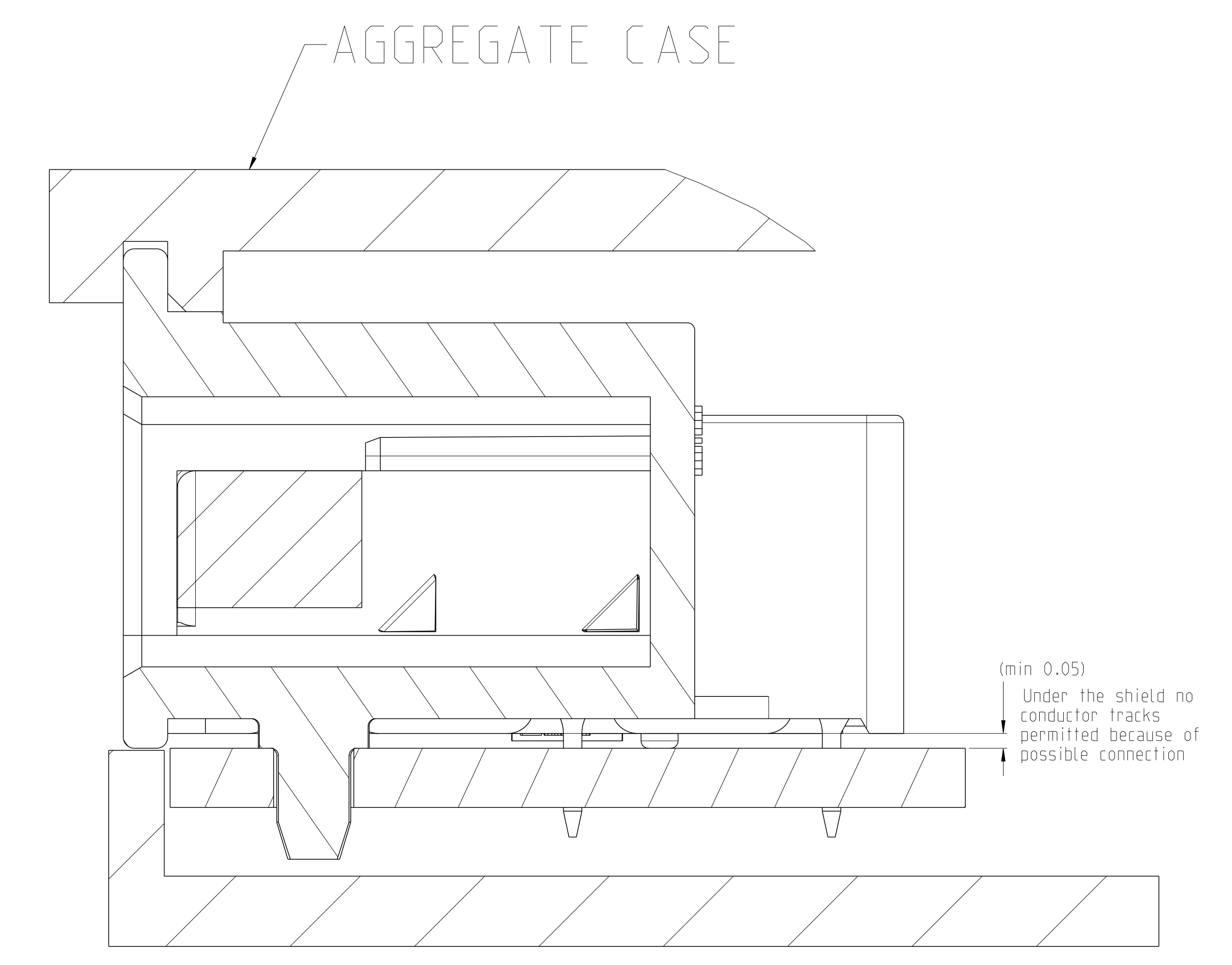

THIS DRAWING IS A CONTROLLED DOCUMENT.		DATE: 09AUG2016	BY: M. M. S.	APPROVED: 10AUG2016	BY: A. Burkhard
DIMENSIONS:	UNLESS OTHERWISE SPECIFIED:	UNIT:	SCALE:	PROJECT:	PRODUCT SPEC:
0 P.L.C.	mm	mm	1:1	2 PORT HEADER ASSY	2 Part Header ASSY
1 P.L.C.	mm	mm	1:1		
2 P.L.C.	mm	mm	1:1		
3 P.L.C.	mm	mm	1:1		
4 P.L.C.	mm	mm	1:1		
5 P.L.C.	mm	mm	1:1		
6 P.L.C.	mm	mm	1:1		
7 P.L.C.	mm	mm	1:1		
8 P.L.C.	mm	mm	1:1		
9 P.L.C.	mm	mm	1:1		
10 P.L.C.	mm	mm	1:1		
11 P.L.C.	mm	mm	1:1		
12 P.L.C.	mm	mm	1:1		
13 P.L.C.	mm	mm	1:1		
14 P.L.C.	mm	mm	1:1		
15 P.L.C.	mm	mm	1:1		
16 P.L.C.	mm	mm	1:1		
17 P.L.C.	mm	mm	1:1		
18 P.L.C.	mm	mm	1:1		
19 P.L.C.	mm	mm	1:1		
20 P.L.C.	mm	mm	1:1		
21 P.L.C.	mm	mm	1:1		
22 P.L.C.	mm	mm	1:1		
23 P.L.C.	mm	mm	1:1		
24 P.L.C.	mm	mm	1:1		
25 P.L.C.	mm	mm	1:1		
26 P.L.C.	mm	mm	1:1		
27 P.L.C.	mm	mm	1:1		
28 P.L.C.	mm	mm	1:1		
29 P.L.C.	mm	mm	1:1		
30 P.L.C.	mm	mm	1:1		
31 P.L.C.	mm	mm	1:1		
32 P.L.C.	mm	mm	1:1		
33 P.L.C.	mm	mm	1:1		
34 P.L.C.	mm	mm	1:1		
35 P.L.C.	mm	mm	1:1		
36 P.L.C.	mm	mm	1:1		
37 P.L.C.	mm	mm	1:1		
38 P.L.C.	mm	mm	1:1		
39 P.L.C.	mm	mm	1:1		
40 P.L.C.	mm	mm	1:1		
41 P.L.C.	mm	mm	1:1		
42 P.L.C.	mm	mm	1:1		
43 P.L.C.	mm	mm	1:1		
44 P.L.C.	mm	mm	1:1		
45 P.L.C.	mm	mm	1:1		
46 P.L.C.	mm	mm	1:1		
47 P.L.C.	mm	mm	1:1		
48 P.L.C.	mm	mm	1:1		
49 P.L.C.	mm	mm	1:1		
50 P.L.C.	mm	mm	1:1		
51 P.L.C.	mm	mm	1:1		
52 P.L.C.	mm	mm	1:1		
53 P.L.C.	mm	mm	1:1		
54 P.L.C.	mm	mm	1:1		
55 P.L.C.	mm	mm	1:1		
56 P.L.C.	mm	mm	1:1		
57 P.L.C.	mm	mm	1:1		
58 P.L.C.	mm	mm	1:1		
59 P.L.C.	mm	mm	1:1		
60 P.L.C.	mm	mm	1:1		
61 P.L.C.	mm	mm	1:1		
62 P.L.C.	mm	mm	1:1		
63 P.L.C.	mm	mm	1:1		
64 P.L.C.	mm	mm	1:1		
65 P.L.C.	mm	mm	1:1		
66 P.L.C.	mm	mm	1:1		
67 P.L.C.	mm	mm	1:1		
68 P.L.C.	mm	mm	1:1		
69 P.L.C.	mm	mm	1:1		
70 P.L.C.	mm	mm	1:1		
71 P.L.C.	mm	mm	1:1		
72 P.L.C.	mm	mm	1:1		
73 P.L.C.	mm	mm	1:1		
74 P.L.C.	mm	mm	1:1		
75 P.L.C.	mm	mm	1:1		
76 P.L.C.	mm	mm	1:1		
77 P.L.C.	mm	mm	1:1		
78 P.L.C.	mm	mm	1:1		
79 P.L.C.	mm	mm	1:1		
80 P.L.C.	mm	mm	1:1		
81 P.L.C.	mm	mm	1:1		
82 P.L.C.	mm	mm	1:1		
83 P.L.C.	mm	mm	1:1		
84 P.L.C.	mm	mm	1:1		
85 P.L.C.	mm	mm	1:1		
86 P.L.C.	mm	mm	1:1		
87 P.L.C.	mm	mm	1:1		
88 P.L.C.	mm	mm	1:1		
89 P.L.C.	mm	mm	1:1		
90 P.L.C.	mm	mm	1:1		
91 P.L.C.	mm	mm	1:1		
92 P.L.C.	mm	mm	1:1		
93 P.L.C.	mm	mm	1:1		
94 P.L.C.	mm	mm	1:1		
95 P.L.C.	mm	mm	1:1		
96 P.L.C.	mm	mm	1:1		
97 P.L.C.	mm	mm	1:1		
98 P.L.C.	mm	mm	1:1		
99 P.L.C.	mm	mm	1:1		
100 P.L.C.	mm	mm	1:1		