

② CODING B.C
2301695-2 AS SHOWN

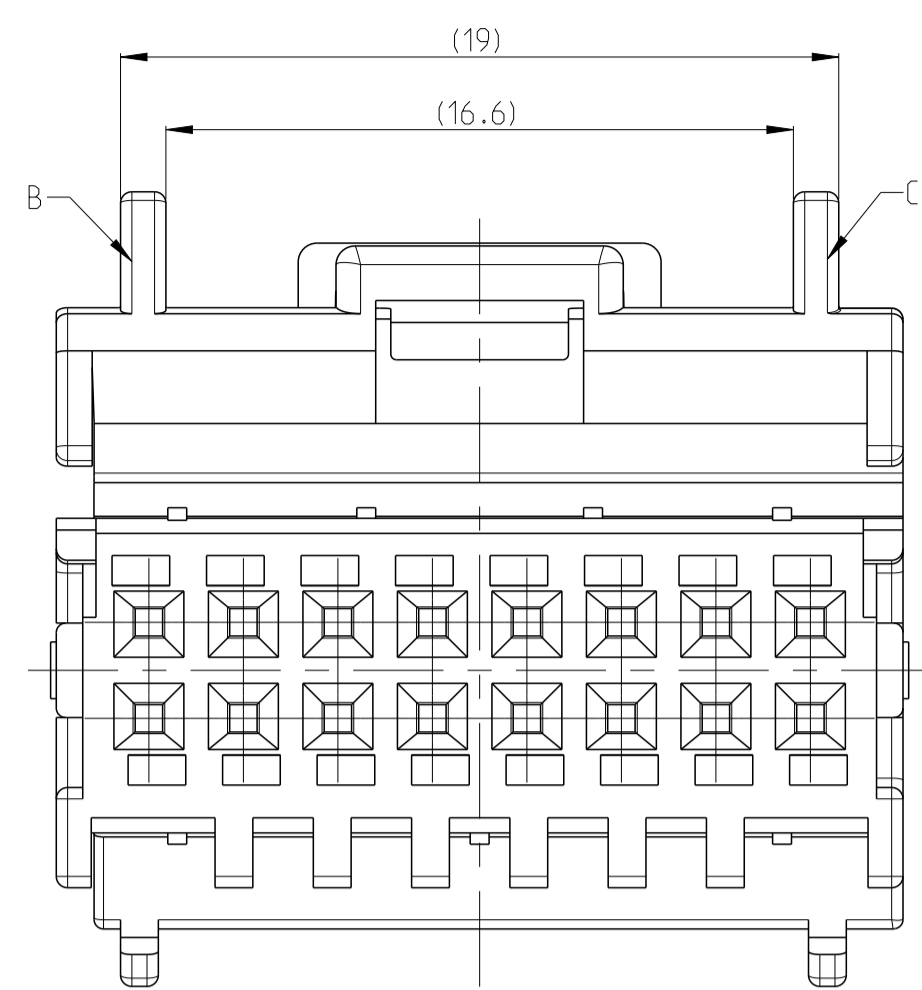

① CODING A.D
2301695-1 AS SHOWN

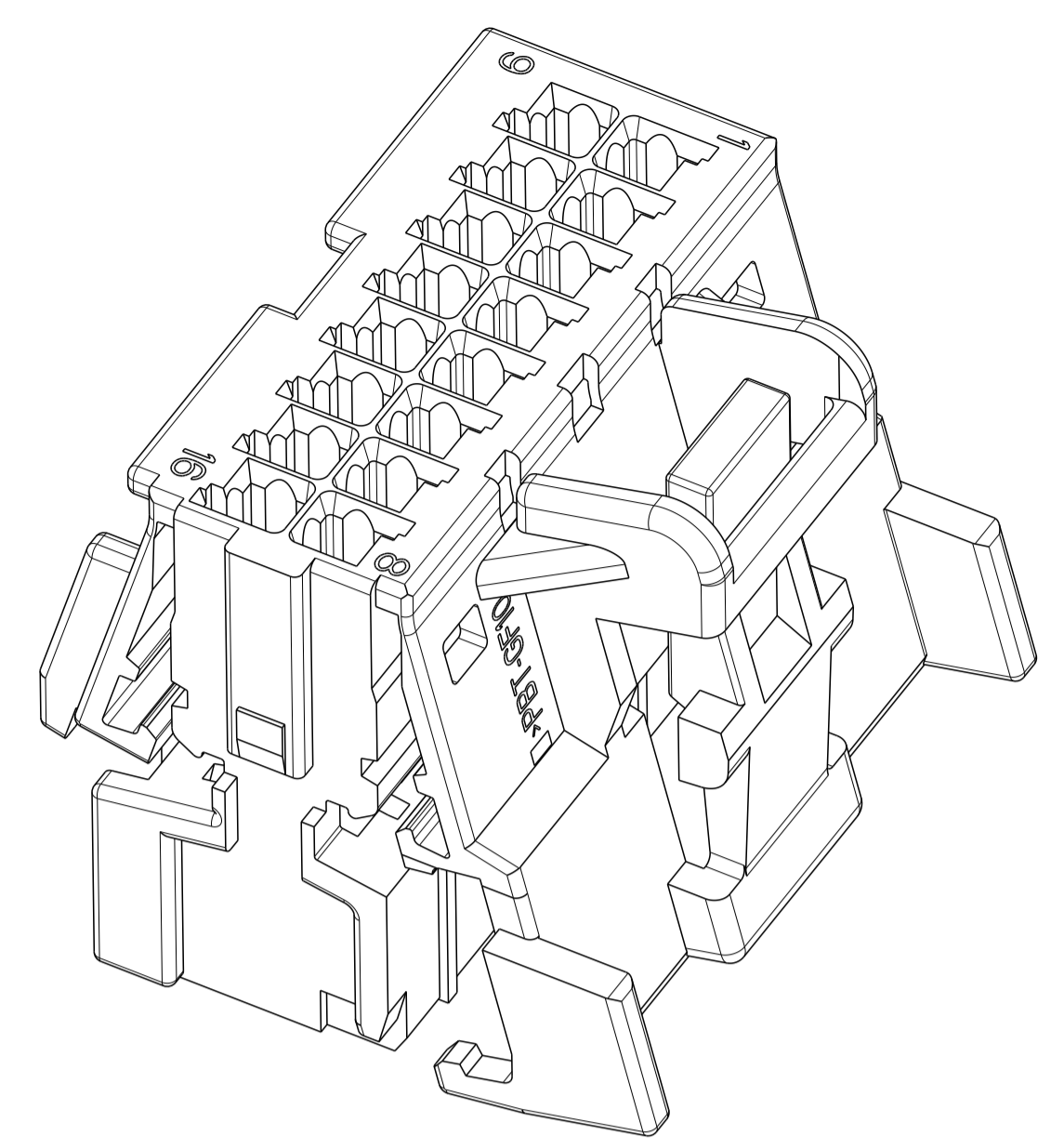
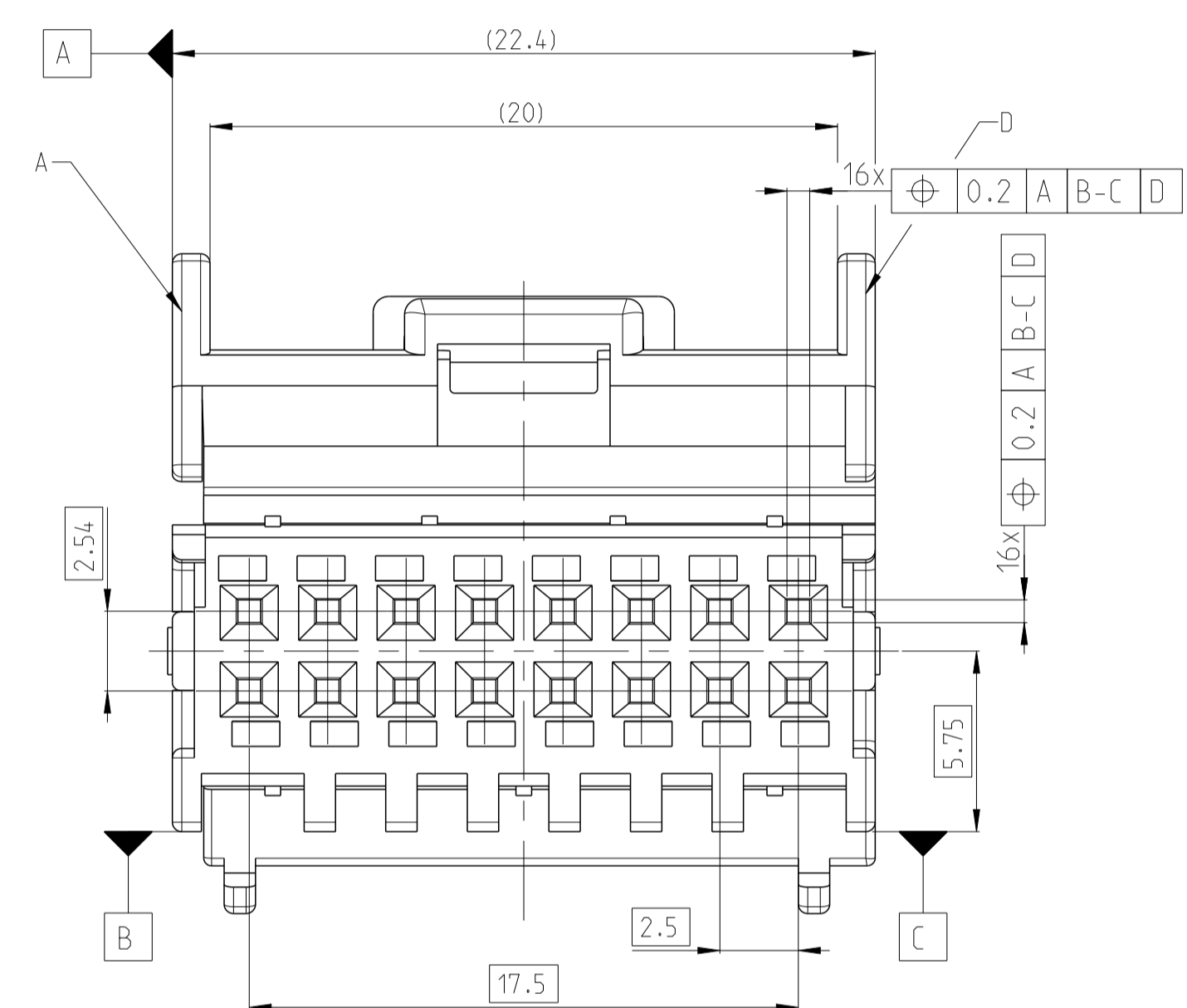

RETAINER CLOSED PICTURED

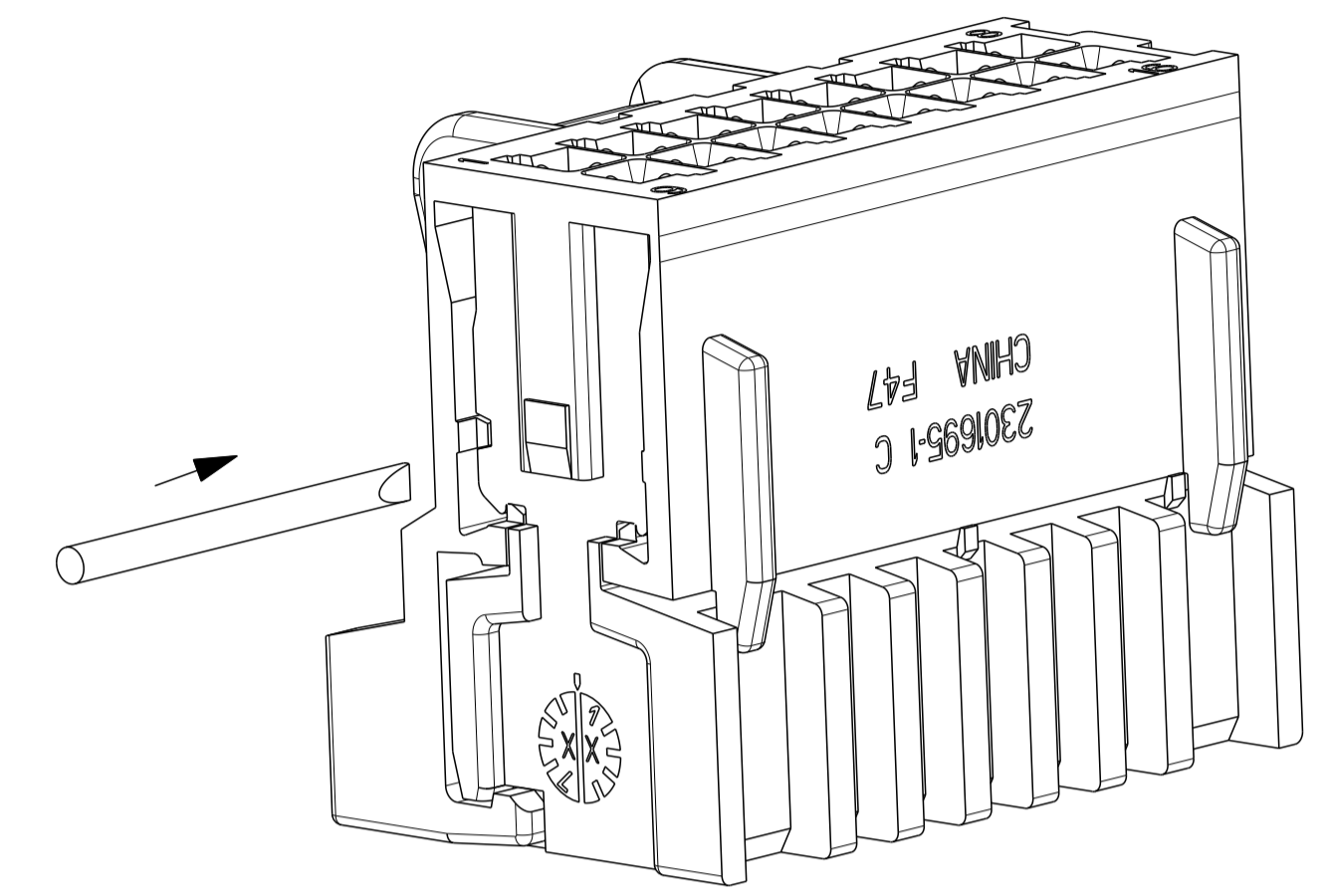

△ OPENING GUIDE: TO OPEN THE LOCKED RETAINER, USE A Ø 1x0.18MM SCREWDRIVER AND PUSH IT IN THE SHOWN OPENING.

NOTES

- MATING PART EXECUTION ACC. 114-18629
- SUITABLE CONTACTS 1355717, 928999, 963715
- SUITABLE MATING HOUSING 2298645, 966870
- MATERIAL REMOVAL OPTIONAL IN EXECUTION AND POSITION ACC. TO MANUFACTURER POSSIBLE
- PACKAGING: LOOSE PIECE IN CARDBOX
- △ CONDITION ON DELIVERY: SECONDARY LOCK DEVICE SHOULD BE IN PRELOCK POSITION --IF IN ENDLOCK POSITION AFTER TRANSPORTATION. PLEASE REOPEN IT IN ACCORDANCE THE OPENING GUIDE
- *-2301695-* IS SUZHOU VERSION OF *-1563336-* BOTH HAVE THE SIMILAR PERFORMANCE.

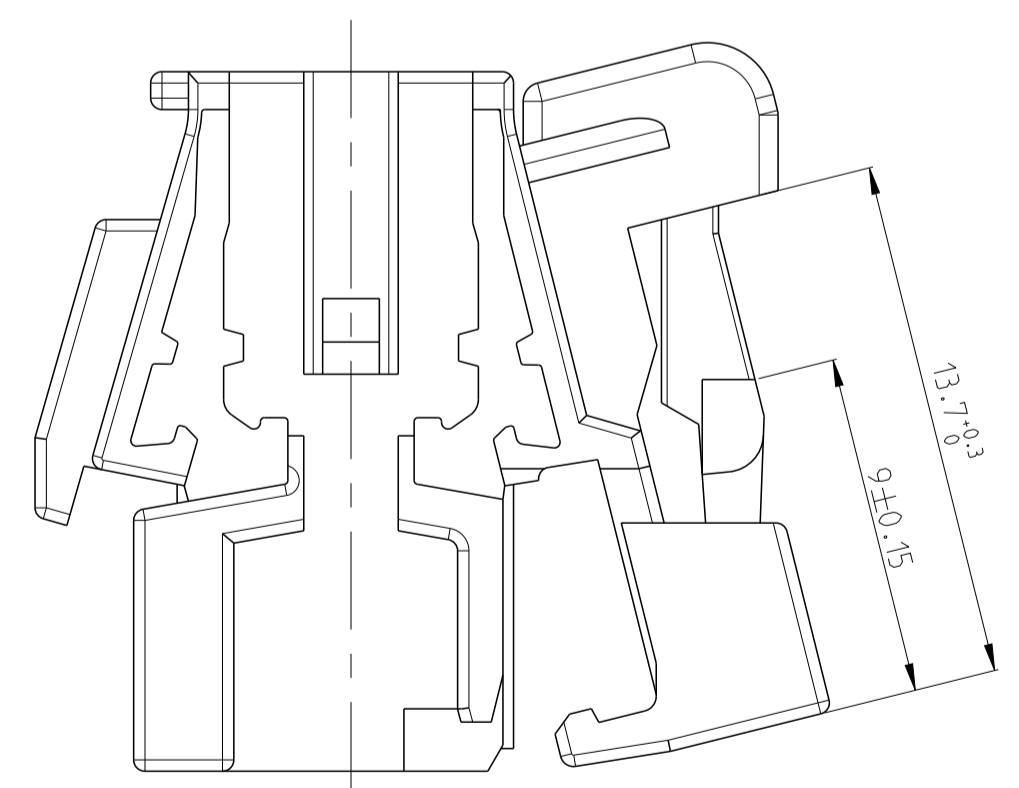
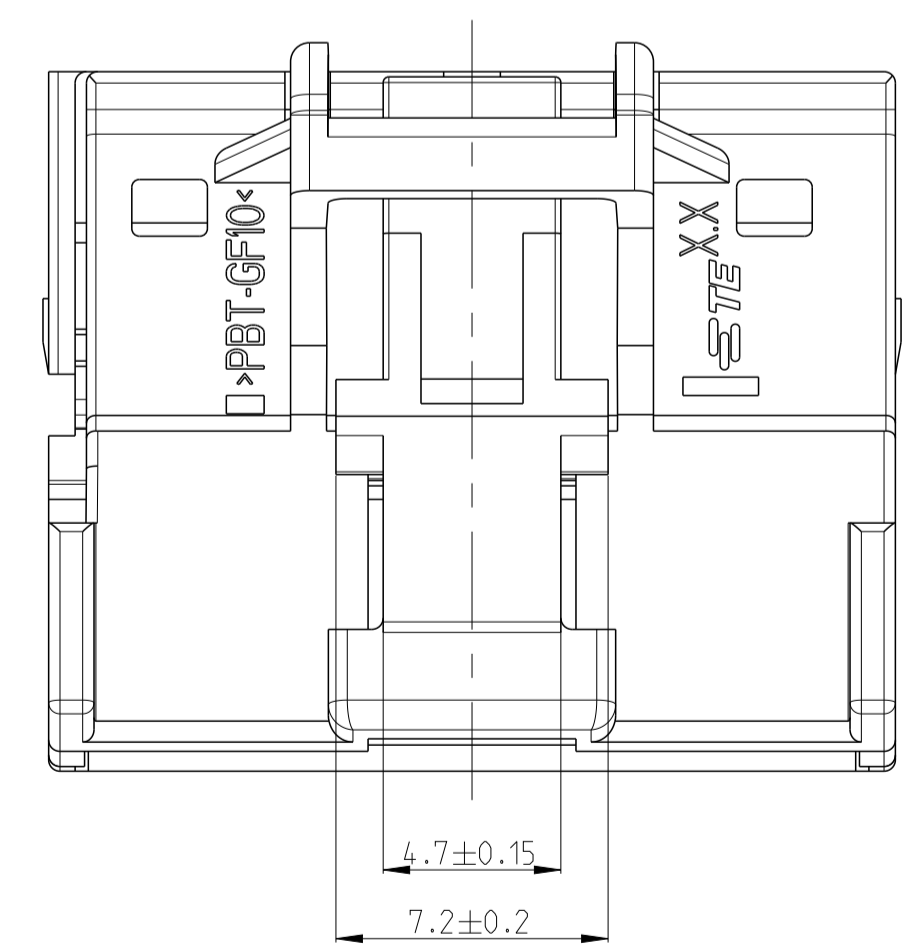
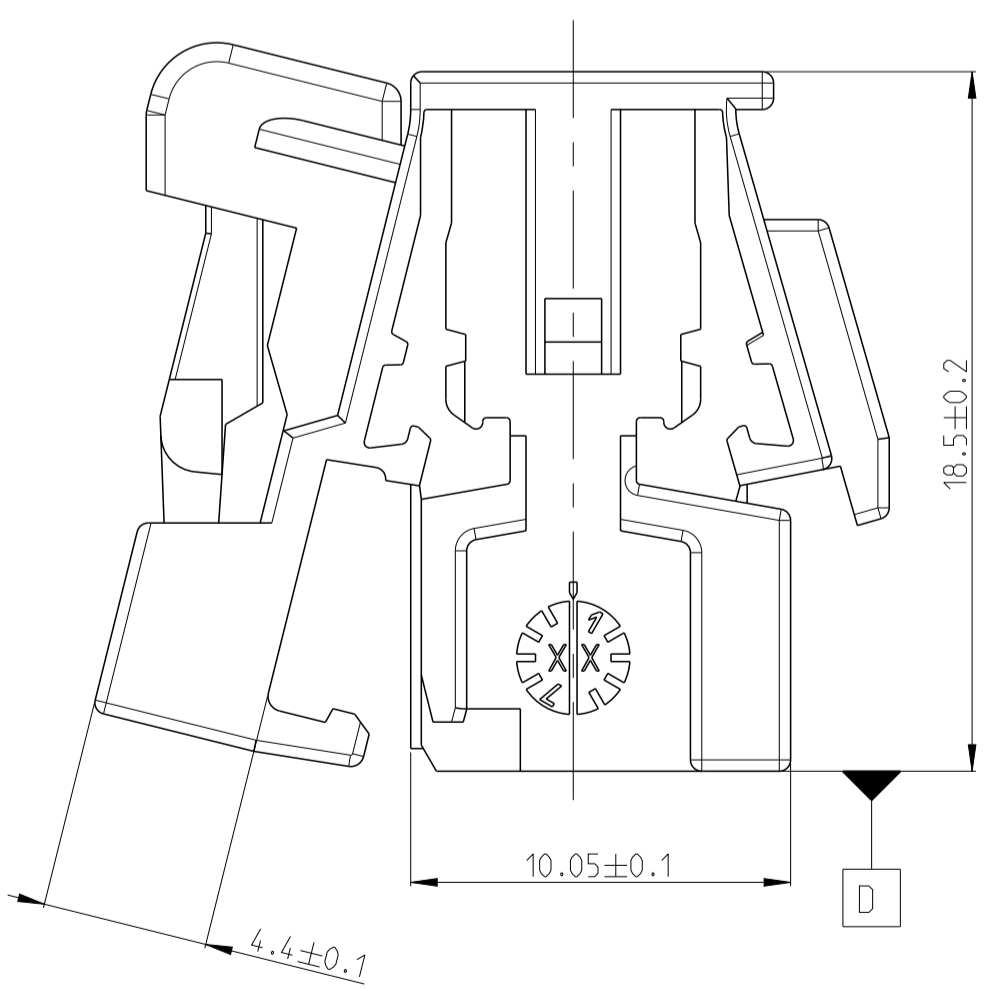

PART NO	REV.	COD.	MATERIAL	COLOUR	RAL	WEIGHT [g]	ITEM NO.
2301695-5	C	A.C	PBT-GF10	GREEN	6018	3.3	5
2301695-4	C	B.D	PBT-GF10	BLUE	5012	3.3	4
2301695-3	C	A.C	PBT-GF10	NATURAL	-	3.3	3
2301695-2	C	B.C	PBT-GF10	BROWN	1011	3.3	2
2301695-1	C	A.D	PBT-GF10	BLACK	9011	3.3	1

THIS DRAWING IS A CONTROLLED DOCUMENT. DIMENSIONING AND TOLERANCING PER GPS (ISO STANDARDS)

TE Connectivity

16POS. MQS REC. HOUSING

00779 2301695

SCALE 5:1 SHEET 1 OF 1 REV C3