

NOTES

1. ALL DIMENSIONS ARE IN  $\frac{\text{INCHES}}{\text{[MILLIMETERS]}}$
2. DIMENSIONS APPEARING IN TABLE ARE AS FOLLOWS:
  - a - AS SUPPLIED
  - b - AFTER UNRESTRICTED RECOVERY
3. COATING IS OPTIONAL. AS SUPPLIED DIMENSIONS APPEARING IN TABLE ARE FOR UNCOATED PARTS. WHEN COATING IS ADDED, ENTRY DIAMETERS WILL BE REDUCED BY .06 MAX.

REVISIONS		
LTR	DESCRIPTION	DATE
A	ECD-08-000854	01/10/2008

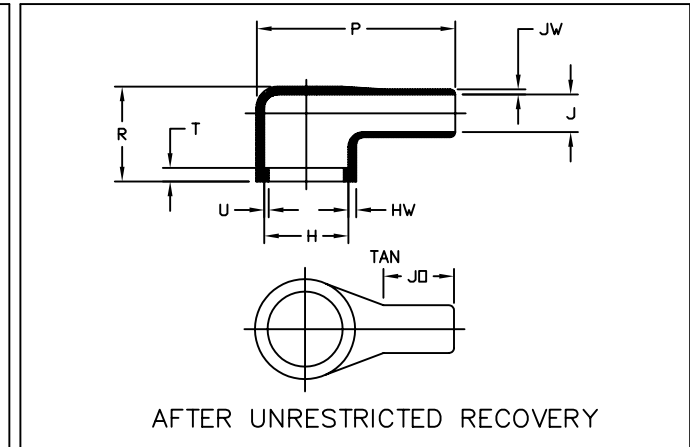
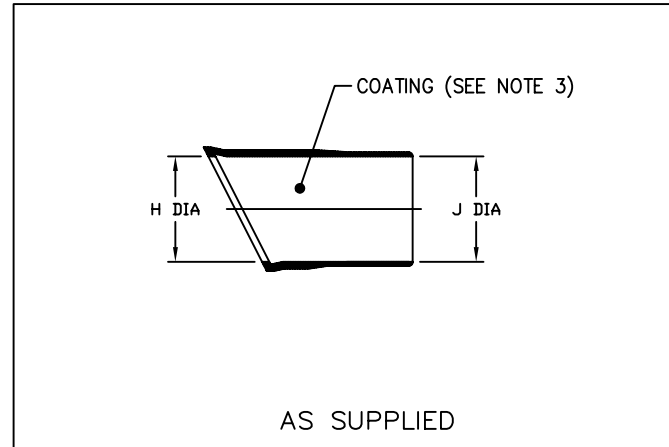

PART NUMBER	H		J		P ±10%	R REF	T REF	U REF	JO REF	HW ±20%	JW ±20%
	MIN	MAX	MIN	MAX							
	a	b	a	b							
222D242-3-21/42	$\frac{1.34}{[34,0]}$	$\frac{.90}{[22,9]}$	$\frac{1.34}{[34,0]}$	$\frac{.38}{[9,7]}$	$\frac{3.50}{[88,9]}$	$\frac{.86}{[21,8]}$	$\frac{.12}{[3,0]}$	$\frac{.04}{[1,0]}$	$\frac{1.67}{[42,4]}$	$\frac{.07}{[1,7]}$	$\frac{.045}{[1,1]}$

If this document is printed it becomes uncontrolled. Check for the latest revision

CUSTOMER DRAWING

UNLESS OTHERWISE SPECIFIED DIMENSIONS ARE INCHES. METRIC DIMENSIONS ARE IN BRACKETS.	DRAWN UNGUYEN	DATE 01/10/2008	 Raychem Molded Parts 305 Constitution Dr Menlo Park, CA 94025
	RPN CL9153-000	TITLE BOOT, 90 DEGREE, WITH LIP	
DECIMAL TOLERANCES .XXX ± 0.005 [0.13 mm] .XX ± 0.01 [0.25 mm] .X ± 0.1 [0.50 mm]	THIRD ANGLE PROJECTION		SIZE B
ANGLE TOLERANCE .X ± 1 DEG.	© 2008 Tyco Electronics Corporation. All rights reserved.		CODE IDENT. NO. 06090
		DVG. NO. 222D242-3-21/42	
		DO NOT SCALE THIS DRAWING	
		SHEET 1 OF 2	

4

3

2

1

COMPATIBILITY CHART					
MATERIAL DASH NO.	MATERIAL DESCRIPTION	RT SPEC	COATING SLASH NO.	COATING S NO.	COATING DESCRIPTION
-3	SEMI-RIGID POLYOLEFIN	RT-301	/42	S-1017	ADHESIVE

ORDERING INFORMATION

222D242 -3 -21 /42 -0

BASE PART NUMBER \_\_\_\_\_

MATERIAL DASH NUMBER \_\_\_\_\_  
(SEE COMPATABILITY CHART)

MODIFICATION NUMBER \_\_\_\_\_

ADHESIVE SLASH NUMBER \_\_\_\_\_  
(SEE COMPATIBILITY CHART)

COLOR DESIGNATOR \_\_\_\_\_

If this document is printed it becomes uncontrolled. Check for the latest revision

CUSTOMER DRAWING

SIZE	DWG. NO.	REV	DWG. NO.	
B	06090	A	222D242-3-21/42	
DO NOT SCALE THIS DRAWING			SHEET 2 OF 2	

4

3

2

1