

LOC	DIST	REVISIONS			
P	LTN	DESCRIPTION	DATE	OWN	APPD
B24	ECR-23-189122	ADD NEW VARIANT	10OCT 23	S.X	J.Z
B25	ECR-23-195303		15DEC 23	S.X	J.Z
B26	ECR-24-204228	add variant PN	29MAR 24	S.X	J.Z
B27	ECR-24-208648	add variant pn	13MAY 24	S.X	J.Z

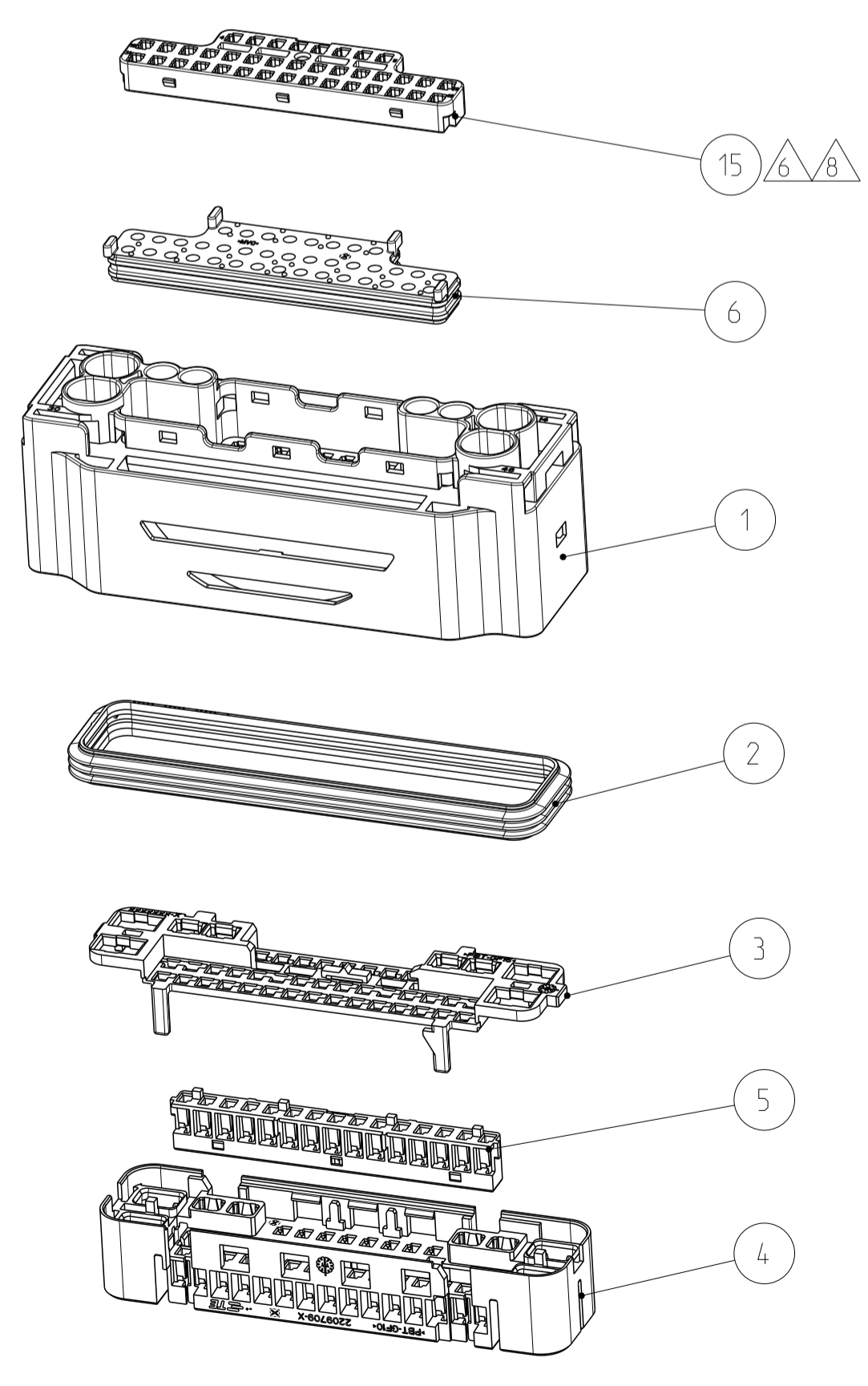
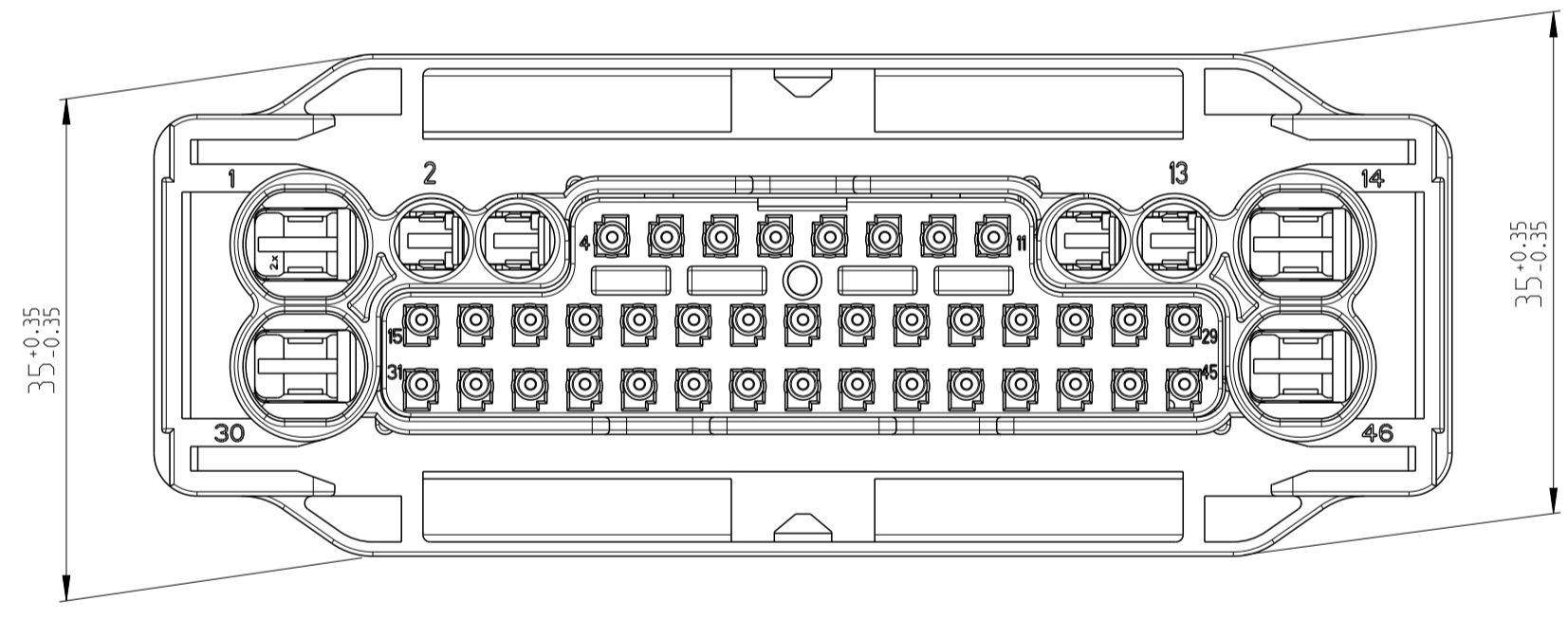
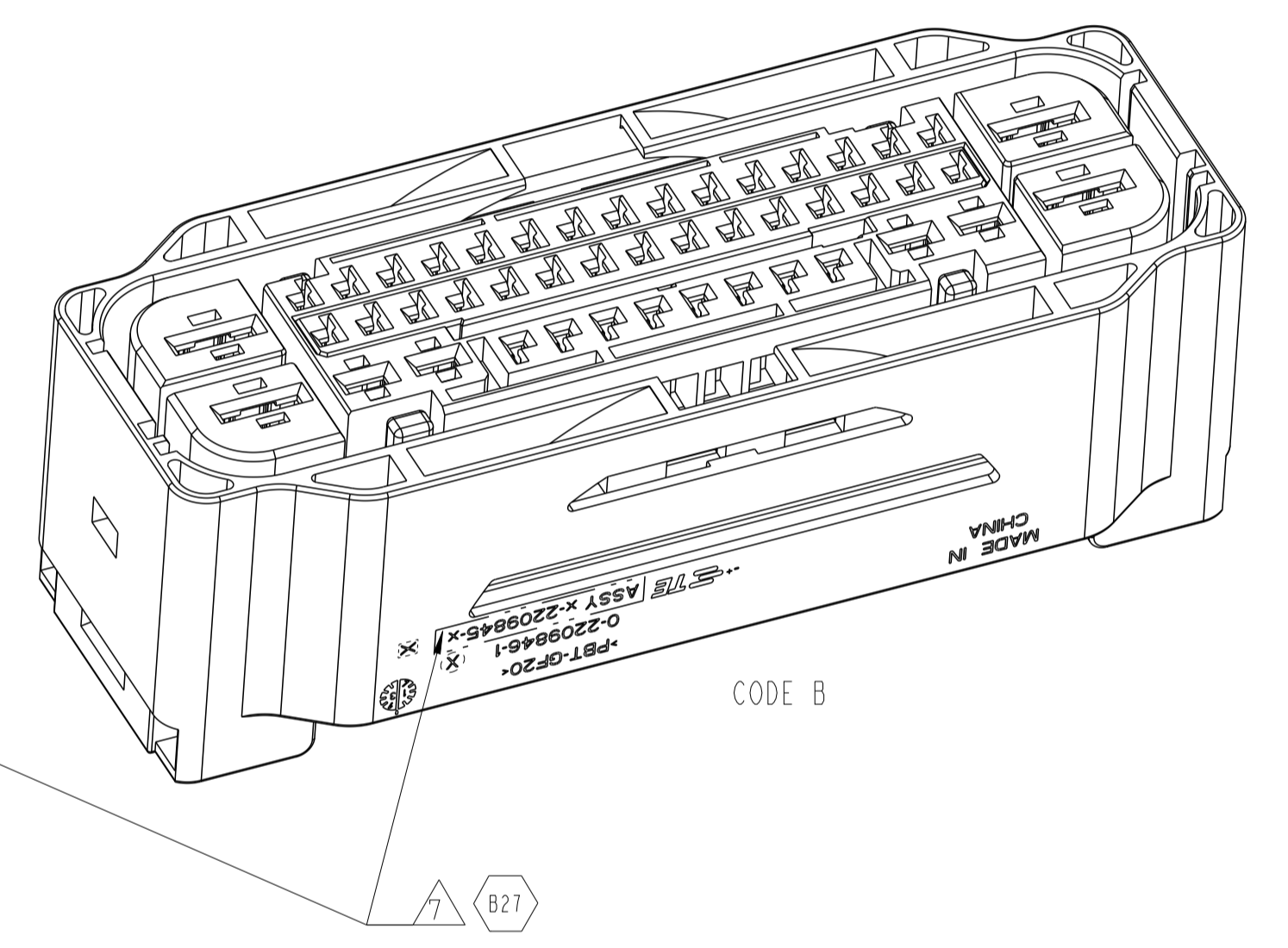
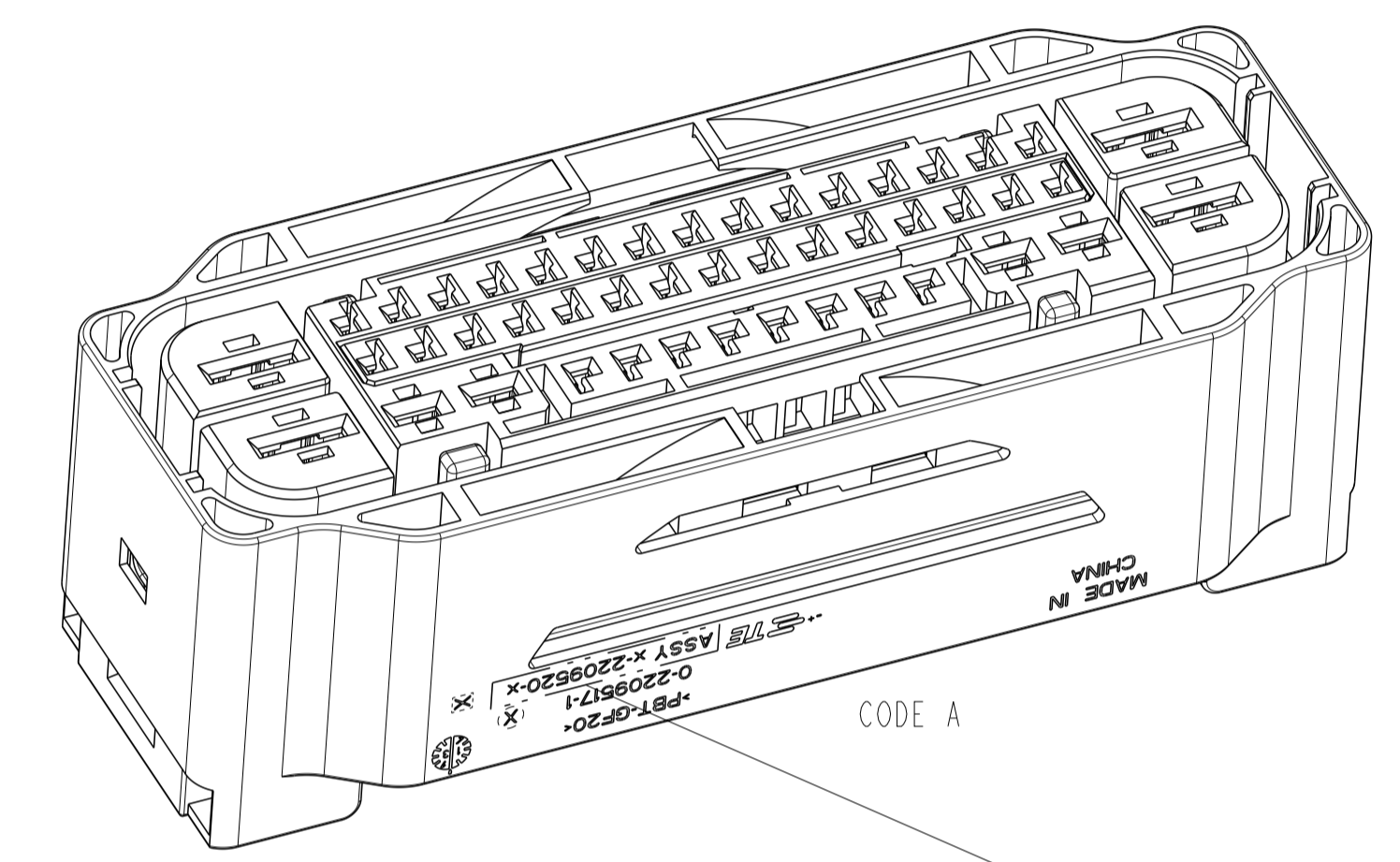
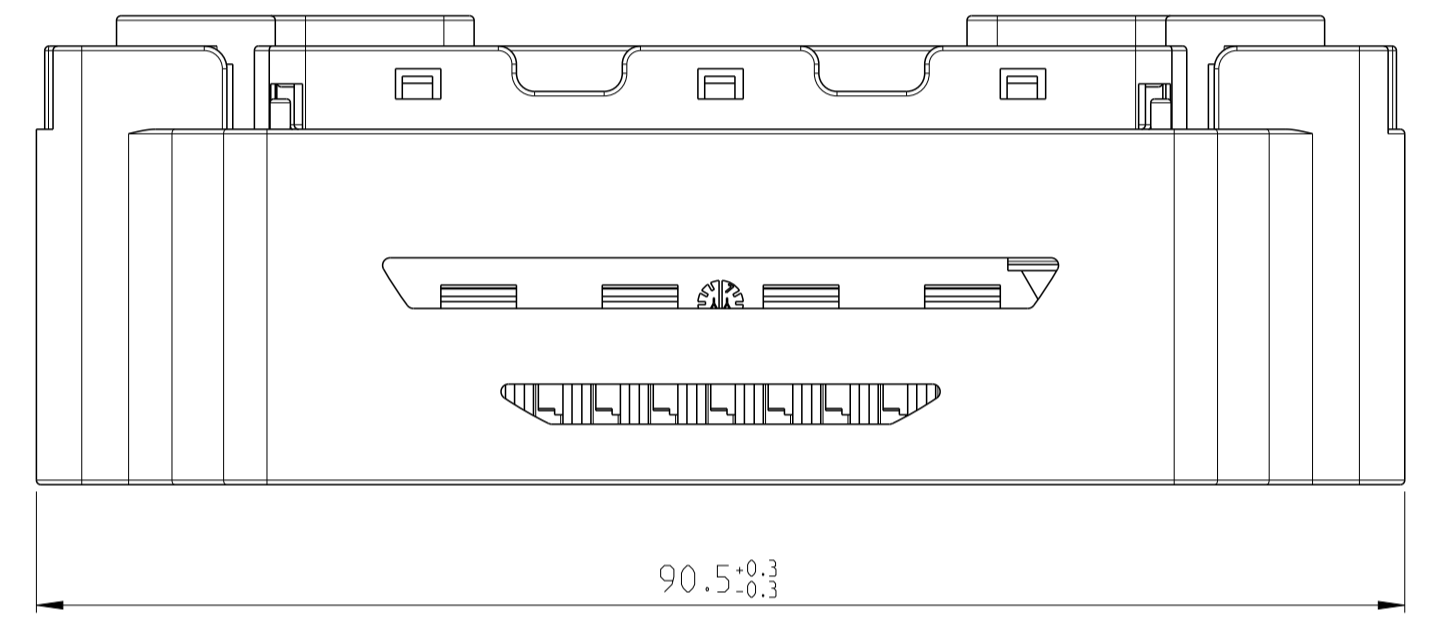
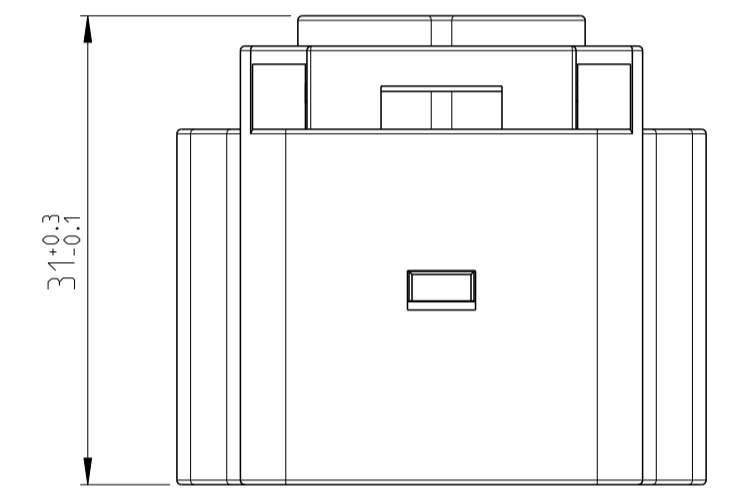
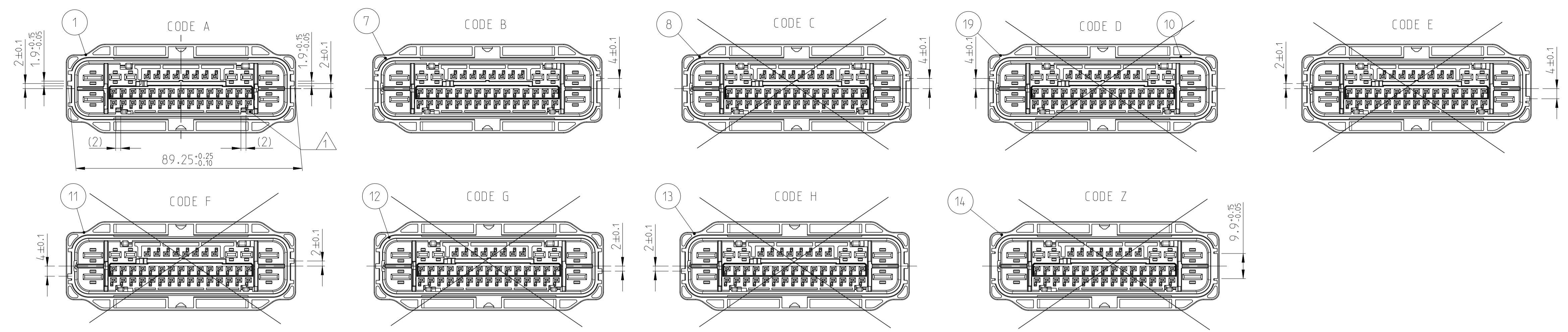

NOTES

- 1 RETAINER (3) IN PRE-LOCKED CONDITION
- 2 USED WITH 2209521 (COVER ASSY)
- 3 PACKING: LAYERS IN BOX
- 4 TE ASSY NO., SEE TABLE
- 5 SUITABLE CONTACTS, E.G.:
 MCON 1.2 CB 1534594-1 OR 2296537-1 FOR 0.35MM2,
 THE DETAIL SEE DRAWING NO. 1534326 AND ONLY
 FOR WIRE ISOLATION OD RANGE ø1.10-1.90MM2

 AMP MCP 2.8K 1241394-1 FOR 0.5-1MM2,
 THE DETAIL SEE DRAWING NO. 1241437

 AMP MCP 4.8K 1241414-1 FOR 1.5-2.5MM2,
 WITH SWS 1394512-1
 AMP MCP 4.8K 1-1241418-3 FOR >4.0 - 6.0MM2
 WITH SWS 1719043-1
 THE DETAIL SEE DRAWING NO. 1241438
- 6 FOR ITEM 15, DETAIL VARIANT(PIN OUT FORM) SEE TABLE OF PAGE 2 & PAGE3
- 7 ASSY P/N NEED LASER MARKING IN ASSY LINE

PN 9-2209520-1 Without SEAL COVER
 USED WITH: SEAL COVER X-2437354-X

COD	TE ASSY-NO	COLOR	MATERIAL	DESCRIPTION	QTY.	ITEM NO
A	9-2209520-1	LIGHT BLUE	SILICONE	FAMILY SEAL	1	6
		BLACK	PBT-GF10	CAVITY BLOCK	1	5
		BLACK	PBT-GF10	CAVITY BLOCK	1	4
		VIOLET	PBT-GF15	RETAINER	1	3
		NATURAL	SILICONE	SEALING	1	2
		BLACK	PBT-GF20	HOUSING 46 POS.	1	1

With SEAL COVER PN X-2209520-X
 MORE PINOUT CONFIGURATION INFORMATION SEES PAGE 2.

COD	TE ASSY-NO	COLOR	MATERIAL	DESCRIPTION	QTY.	ITEM NO
B	9-2209845-9	NATURAL	PBT-GF20	SEAL COVER	1	15
		LIGHT BLUE	SILICONE	FAMILY SEAL	1	6
		BLACK	PBT-GF10	CAVITY BLOCK	1	5
		BLACK	PBT-GF10	CAVITY BLOCK	1	4
		VIOLET	PBT-GF15	RETAINER	1	3
		NATURAL	SILICONE	SEALING	1	2
		BLACK	PBT-GF20	HOUSING 46 POS.	1	7
A	9-2209520-9	NATURAL	PBT-GF20	SEAL COVER	1	15
		LIGHT BLUE	SILICONE	FAMILY SEAL	1	6
		BLACK	PBT-GF10	CAVITY BLOCK	1	5
		BLACK	PBT-GF10	CAVITY BLOCK	1	4
		VIOLET	PBT-GF15	RETAINER	1	3
		NATURAL	SILICONE	SEALING	1	2
		BLACK	PBT-GF20	HOUSING 46 POS.	1	1

9 *-2209520-* IS SUZHOU VERSION PN THAT IS THE SIMILAR PERFORMANCE OF *-2112825-*

THIS DRAWING IS A CONTROLLED DOCUMENT.

DIMENSIONS: mm 	TOLERANCES UNLESS OTHERWISE SPECIFIED: 0 PLC 1 PLC 2 PLC 3 PLC 4 PLC MILES FINISH	DWG: J.ZHONG 04-MAR-13 CHK: A.DANG 04-MAR-13 APVD: LYJIN 04-MAR-13 PRODUCT SPEC: 108-101281 APPLICATION SPEC: 116-101047 WEIGHT: 58.8g	NAME: 46 POS REC HSG. ASSY MCON 1.2CB, MCP 2.8/4.8 mm SIZE: CAGE CODE DRAWING NO RESTRICTED TO: A1 00779 ©=2209520 SCALE: 1:1 SHEET 1 OF 3 REV: B27
-----------------------	--	---	---

CUSTOMER DRAWING

