

THIS DRAWING IS UNPUBLISHED. RELEASED FOR PUBLICATION
 © COPYRIGHT - By - ALL RIGHTS RESERVED.

REVISIONS				
P	LTR	DESCRIPTION	DATE	APVD
F2		REVISED PER ECR-17-014071	30DEC2017	W.H D.Z

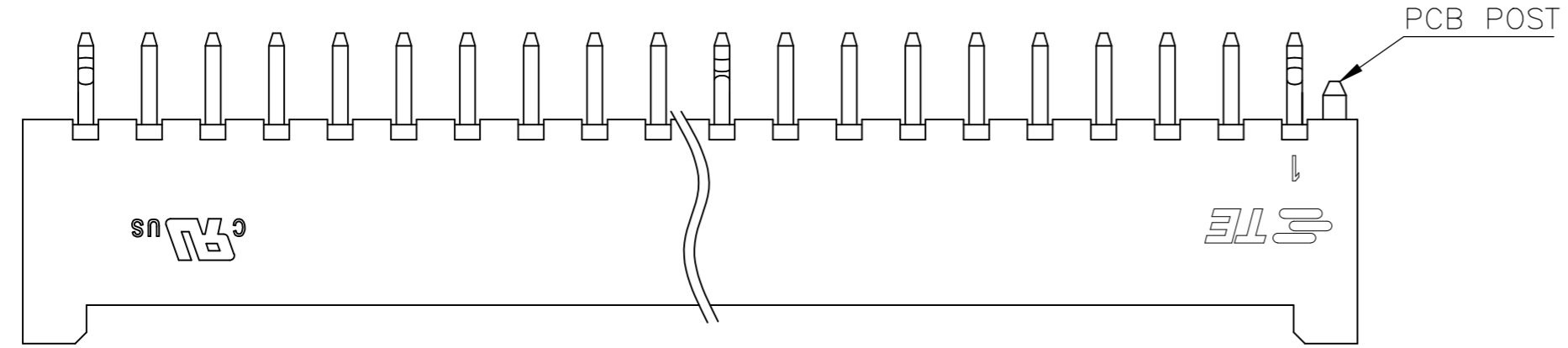

- 1 MATERIAL: HIGH PERFORMANCE RESIN, UL94 V0, COLOR: NATURAL.
- 2 CONTACT RETENTION: 12 NEWTON [2.7 lbf] MIN.
- 3 CONTACT SOLDERTAIL KINK DIRECTION SEE BELOW TABLE.

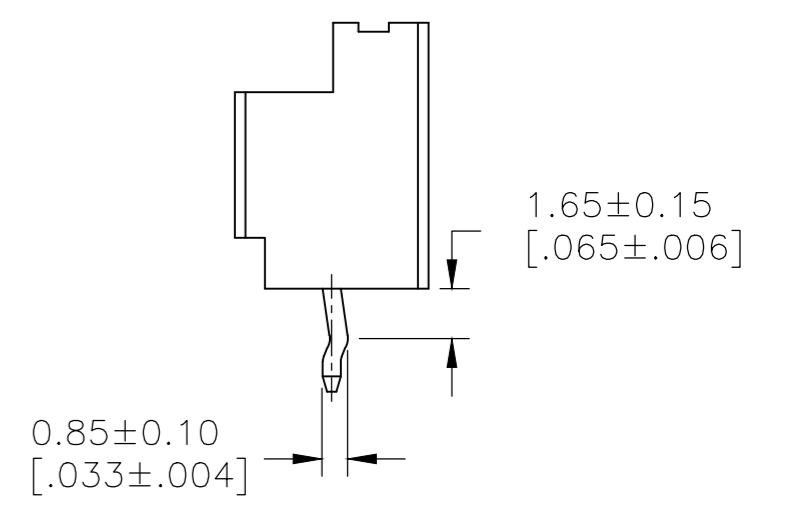
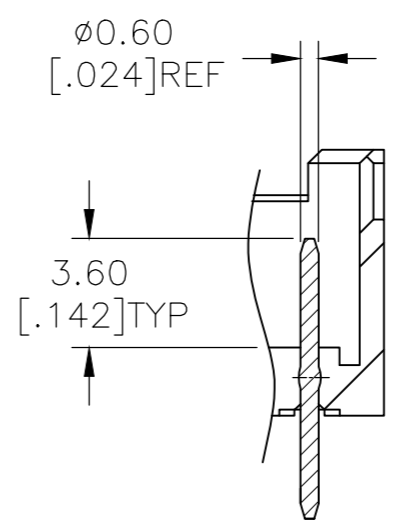
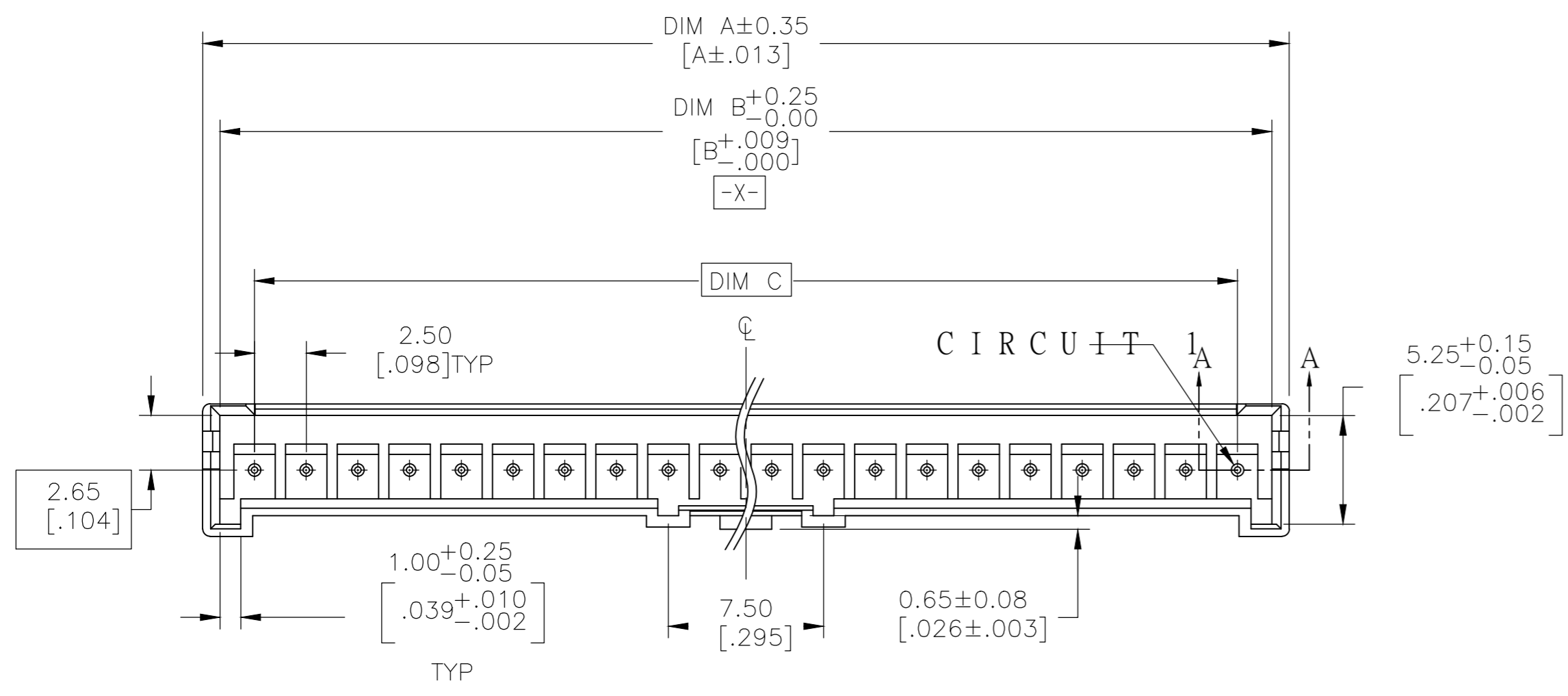

SECTION A - A

MIDDLE

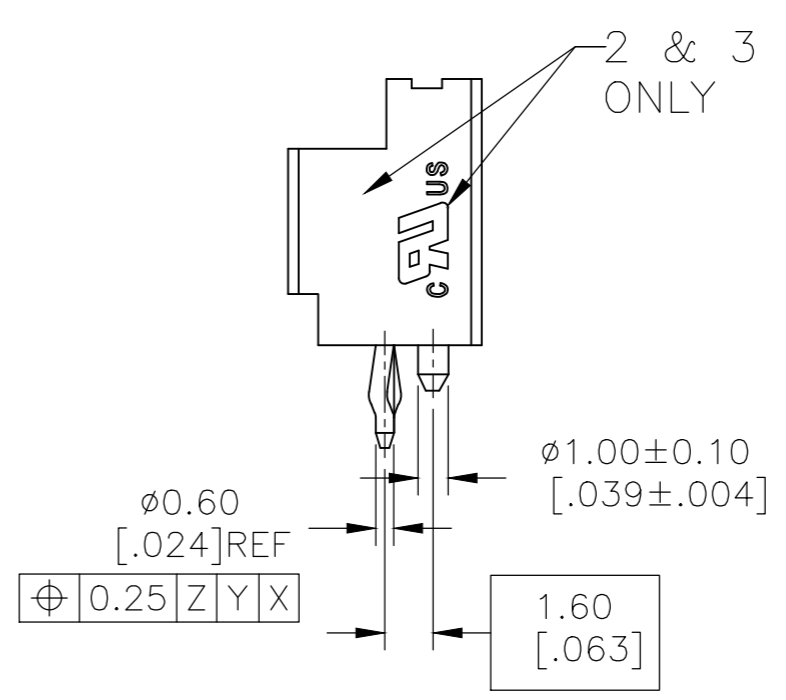
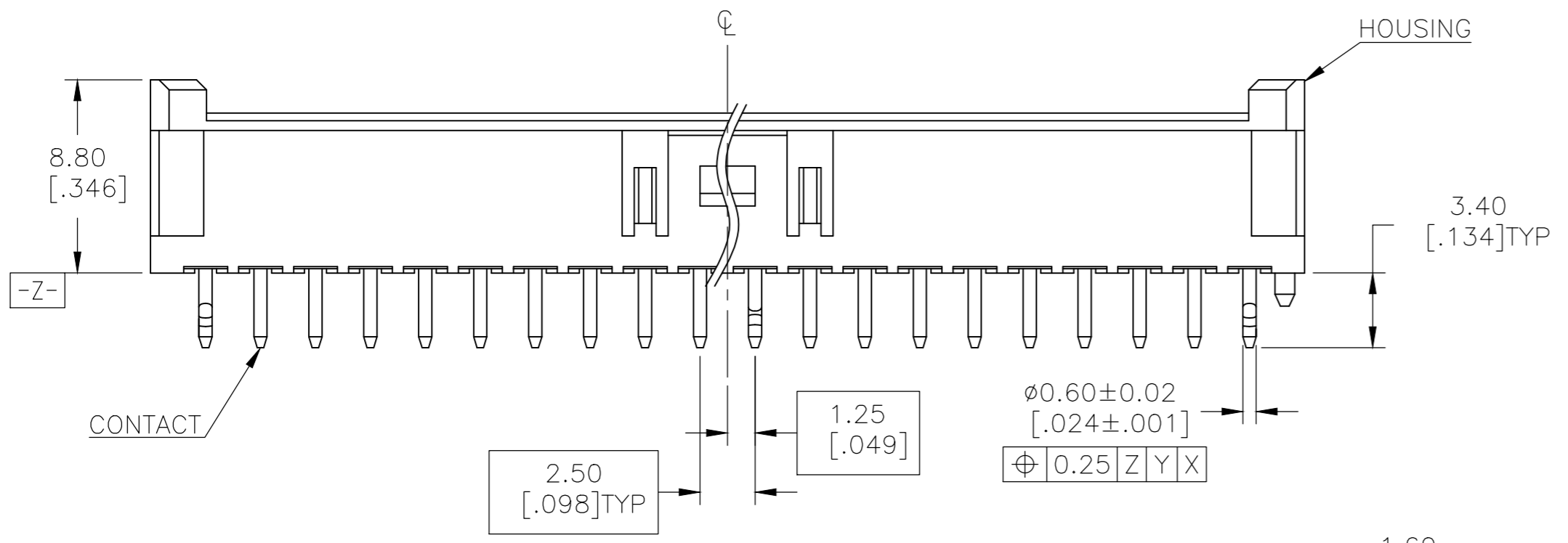

SIDE

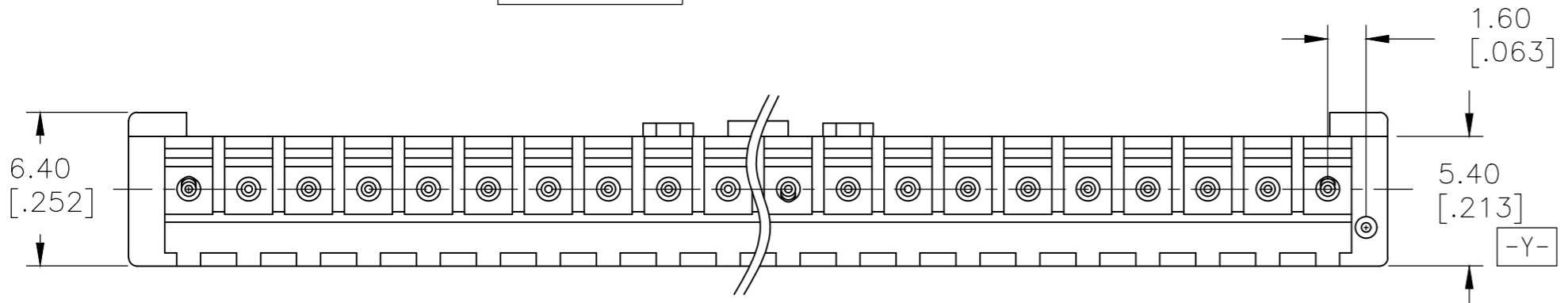

THIS DRAWING IS A CONTROLLED DOCUMENT.		DWN RAGHAVENDRA 06JAN11	TE Connectivity	
DIMENSIONS: mm [INCHES]		CHK MACE SAMUEL 06JAN11		
TOLERANCES UNLESS OTHERWISE SPECIFIED:		APVD MACE SAMUEL 06JAN11	NAME	
0 PLC ± 0.50	1 PLC ± 0.30	PRODUCT SPEC	108-2418 2	
2 PLC ± 0.20	3 PLC ± 0.10	APPLICATION SPEC	114-13315	
4 PLC ± -	ANGLES ± 3°	WEIGHT 0	SIZE A2	CAGE CODE 00779
MATERIAL -	FINISH -	CUSTOMER DRAWING	DRAWING NO C=2132230	RESTRICTED TO -
			SCALE 1:1	SHEET 1 OF 2
			REV F2	

THIS DRAWING IS UNPUBLISHED. RELEASED FOR PUBLICATION
 © COPYRIGHT - By - ALL RIGHTS RESERVED.

REVISIONS					
P	LTR	DESCRIPTION	DATE	DWN	APVD
-	-	SEE SHEET 1	-	-	-

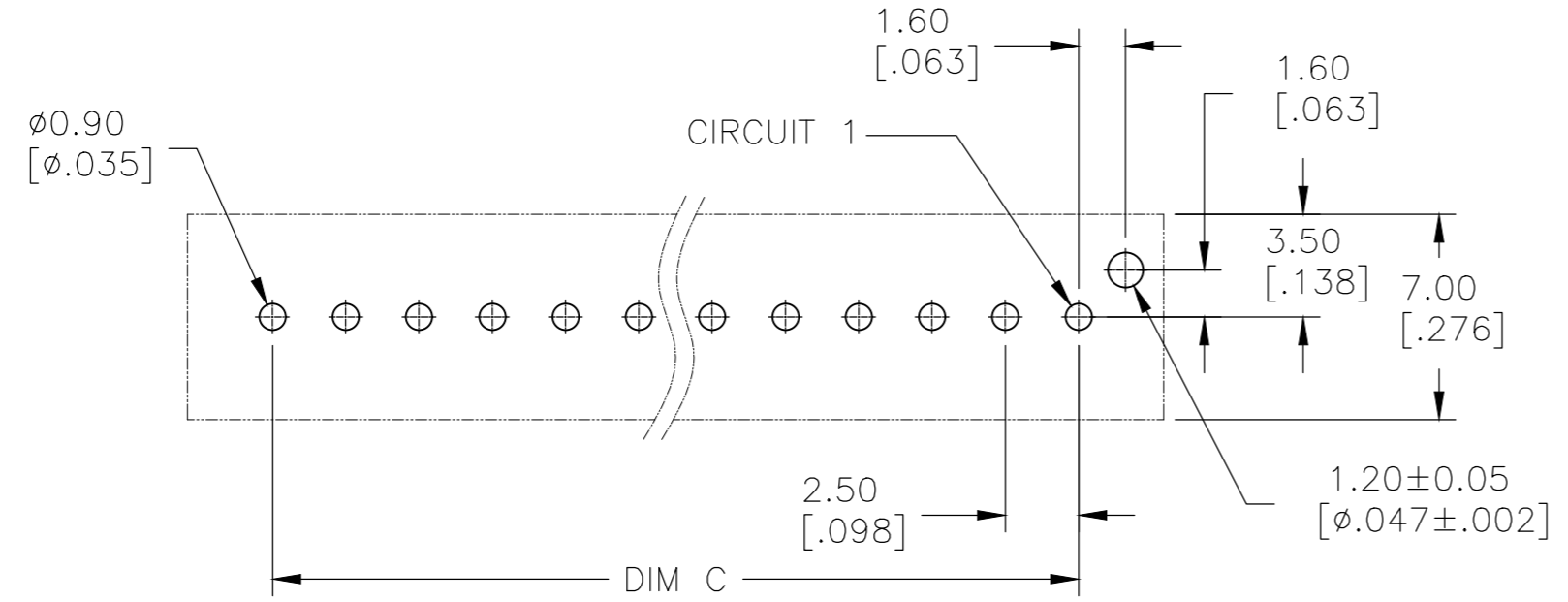
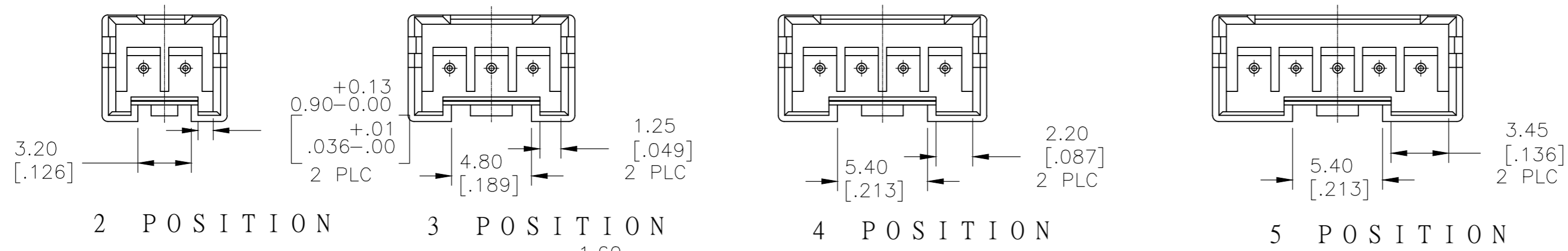

RECOMMENDED PCB LAYOUT

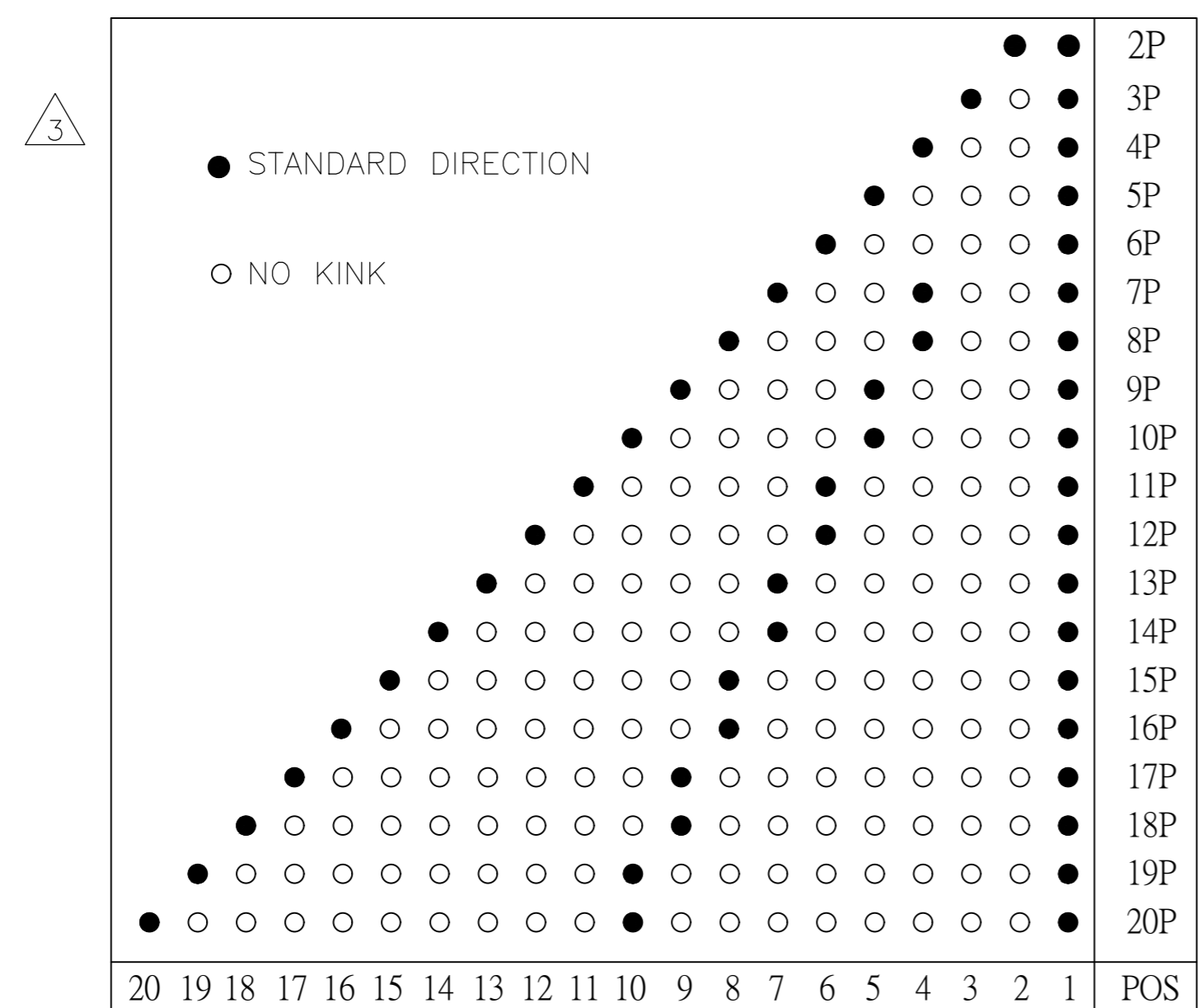

47.5 [1.870]	50.83 [2.001]	52.5 [2.067]	20	2-2132230-0
45.0 [1.772]	48.33 [1.903]	50.0 [1.968]	19	1-2132230-9
42.5 [1.673]	45.83 [1.804]	47.5 [1.870]	18	1-2132230-8
40.0 [1.575]	43.33 [1.706]	45.0 [1.772]	17	1-2132230-7
37.5 [1.476]	40.83 [1.607]	42.5 [1.673]	16	1-2132230-6
35.0 [1.378]	38.33 [1.510]	40.0 [1.575]	15	1-2132230-5
32.5 [1.280]	35.83 [1.411]	37.5 [1.476]	14	1-2132230-4
30.0 [1.181]	33.33 [1.312]	35.0 [1.378]	13	1-2132230-3
27.5 [1.083]	30.83 [.214]	32.5 [1.280]	12	1-2132230-2
25.0 [.984]	28.33 [.115]	30.0 [1.181]	11	1-2132230-1
22.5 [.886]	25.83 [.167]	27.5 [1.083]	10	1-2132230-0
20.0 [.787]	23.33 [.919]	25.0 [.984]	9	2132230-9
17.5 [.689]	20.83 [.820]	22.5 [.886]	8	2132230-8
15.0 [.591]	18.33 [.722]	20.0 [.787]	7	2132230-7
12.5 [.492]	15.83 [.623]	17.5 [.689]	6	2132230-6
10.0 [.394]	13.33 [.525]	15.0 [.591]	5	2132230-5
7.5 [.295]	10.83 [.426]	12.5 [.492]	4	2132230-4
5.0 [.197]	8.33 [.328]	10.0 [.394]	3	2132230-3
2.5 [.098]	5.83 [.229]	7.5 [.295]	2	2132230-2
DIM C	DIM B	DIM A	POS	PART NO

THIS DRAWING IS A CONTROLLED DOCUMENT.		DWN RAGHAVENDRA 06JAN11	TE Connectivity	
DIMENSIONS: mm [INCHES]		CHK MACE SAMUEL 06JAN11	NAME HEADER ASSEMBLY, VERTICAL, ECONOMY POWER, 2.5mm CENTERLINE	
TOLERANCES UNLESS OTHERWISE SPECIFIED:		APVD MACE SAMUEL 06JAN11	PRODUCT SPEC 108-2418	
0 PLC ± 0.50		APPLICATION SPEC 114-13315		
1 PLC ± 0.30		SIZE A2		
2 PLC ± 0.20		CAGE CODE 00779		
3 PLC ± 0.10		DRAWING NO C=2132230		
4 PLC ± .		RESTRICTED TO -		
ANGLES ± 3°		SCALE 1:1		
FINISH		SHEET 2 OF 2		
MATERIAL		REV F1		
WEIGHT		CUSTOMER DRAWING		