

| REVISIONS | | | | |
|-----------|------------------------------|-----------|----|-------|
| REV | DESCRIPTION | DATE | BY | APP'D |
| F | REVISED AS PER ECN-22-148247 | 28MAR2022 | KK | AK |

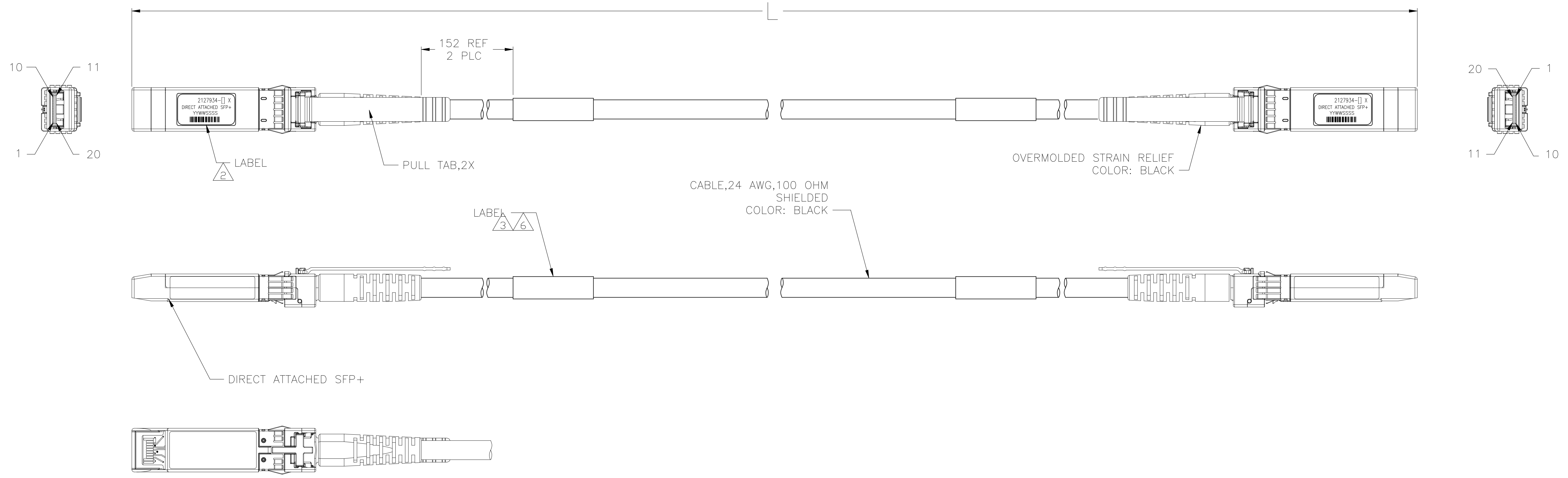

1. CHARACTERISTIC IMPEDANCE: 100±10 OHMS (MEASURED DIFFERENTIALLY).

2 LABEL INFORMATION:

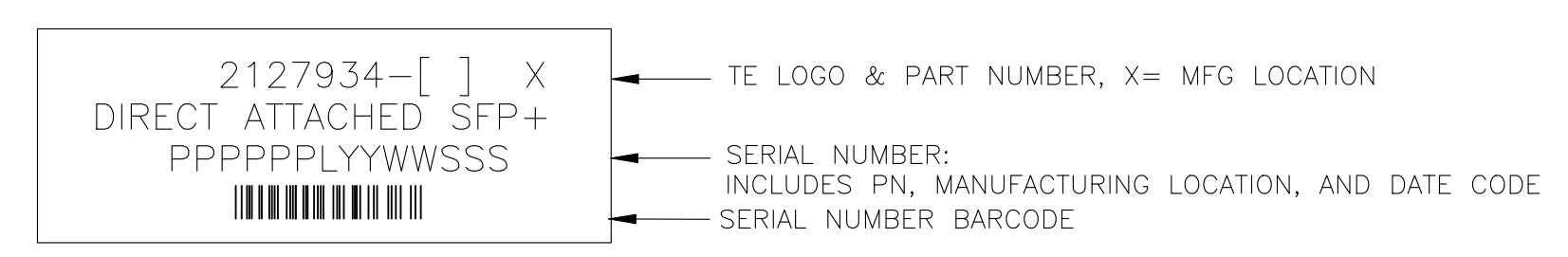

3 LABEL INFORMATION:

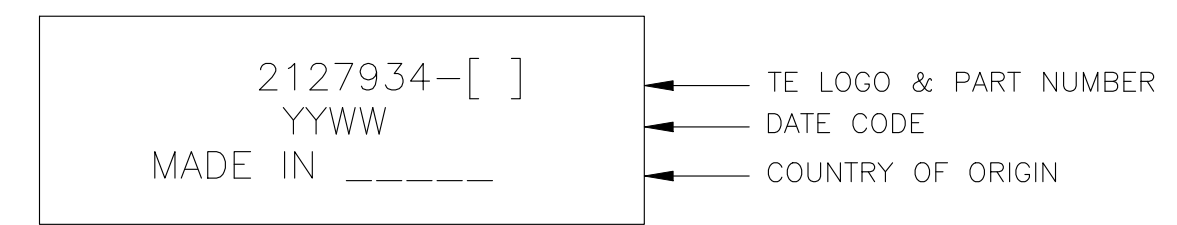

4. SEE SHEET 2 FOR WIRING SCHEMATIC.

5. ROHS COMPLIANCE: PRODUCT AND PROCESSING MEETS REQUIREMENTS OF TE SPECIFICATION TEC-138-702.

6 NO LABEL REQUIRED ON CABLE FOR TE PN:1-2127934-8.

| | | | |
|-----|-------------|--------|-------------|
| 7 | +0.1 -0 | METERS | 1-2127934-8 |
| 10 | +0.12 -0 | METERS | 1-2127934-1 |
| 9 | +0.1 -0 | METERS | 1-2127934-0 |
| 8 | +0.1 -0 | METERS | 2127934-9 |
| 7 | +0.1 -0 | METERS | 2127934-8 |
| 6 | +0.1 -0 | METERS | 2127934-7 |
| 5 | +0.1 -0 | METERS | 2127934-6 |
| 4 | +0.08 -0 | METERS | 2127934-5 |
| 3 | +0.08 -0 | METERS | 2127934-4 |
| 2 | +0.08 -0 | METERS | 2127934-3 |
| 1 | +0.05 -0 | METERS | 2127934-2 |
| 0.5 | +0.05 -0 | METERS | 2127934-1 |
| L | | | PART NO |

THIS DRAWING IS A CONTROLLED DOCUMENT.

| | | | | |
|-------------|--|------------------|-----------|----------------------|
| DIMENSIONS: | TOLERANCES UNLESS OTHERWISE SPECIFIED: | DESIGNED BY | DATE | TE CONNECTIVITY LTD. |
| mm | 0. PLC ± - 1. PLC ± - 2. PLC ± - 3. PLC ± - 4. PLC ± - ANGLES ± - | T. SMITH | 18MAR2010 | |
| MATERIAL | FINISH | CHK | DATE | NAME |
| - | - | C. ADAMS | 18MAR2010 | C. ADAMS |
| | | APPROVED | DATE | PRODUCT SPEC |
| | | G. ADAMS | 18MAR2010 | |
| | | APPLICATION SPEC | | |
| | | WEIGHT | | |
| | | A1 | 00779 | 2127934 |
| | | CUSTOMER DRAWING | SCALE | SHEET |
| | | | 1:1 | 1 OF 2 |

| REVISIONS | | | | |
|-----------|------|----|-------|-------------|
| REV | DATE | BY | APP'D | DESCRIPTION |
| - | - | - | - | SEE SHEET 1 |

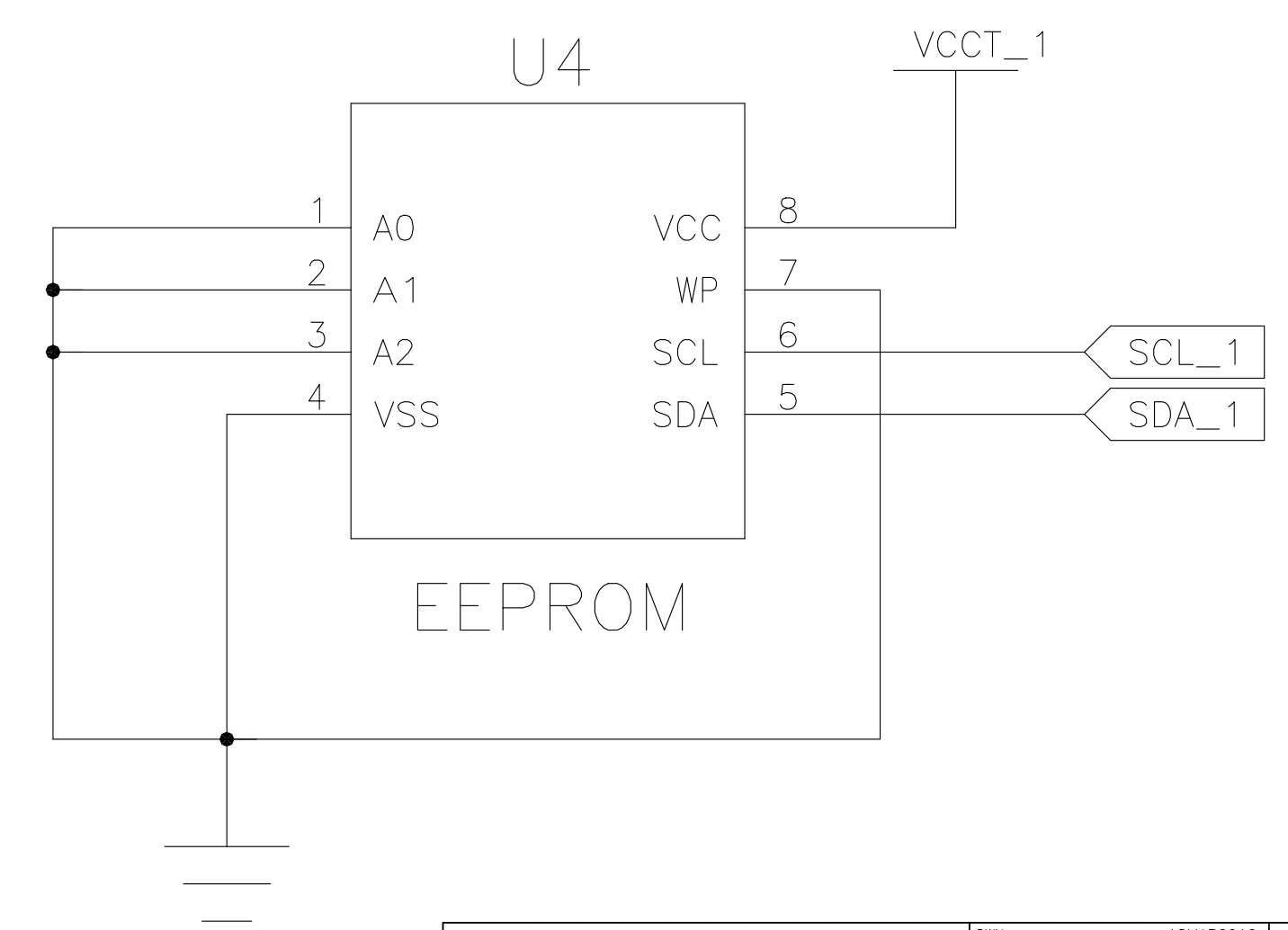
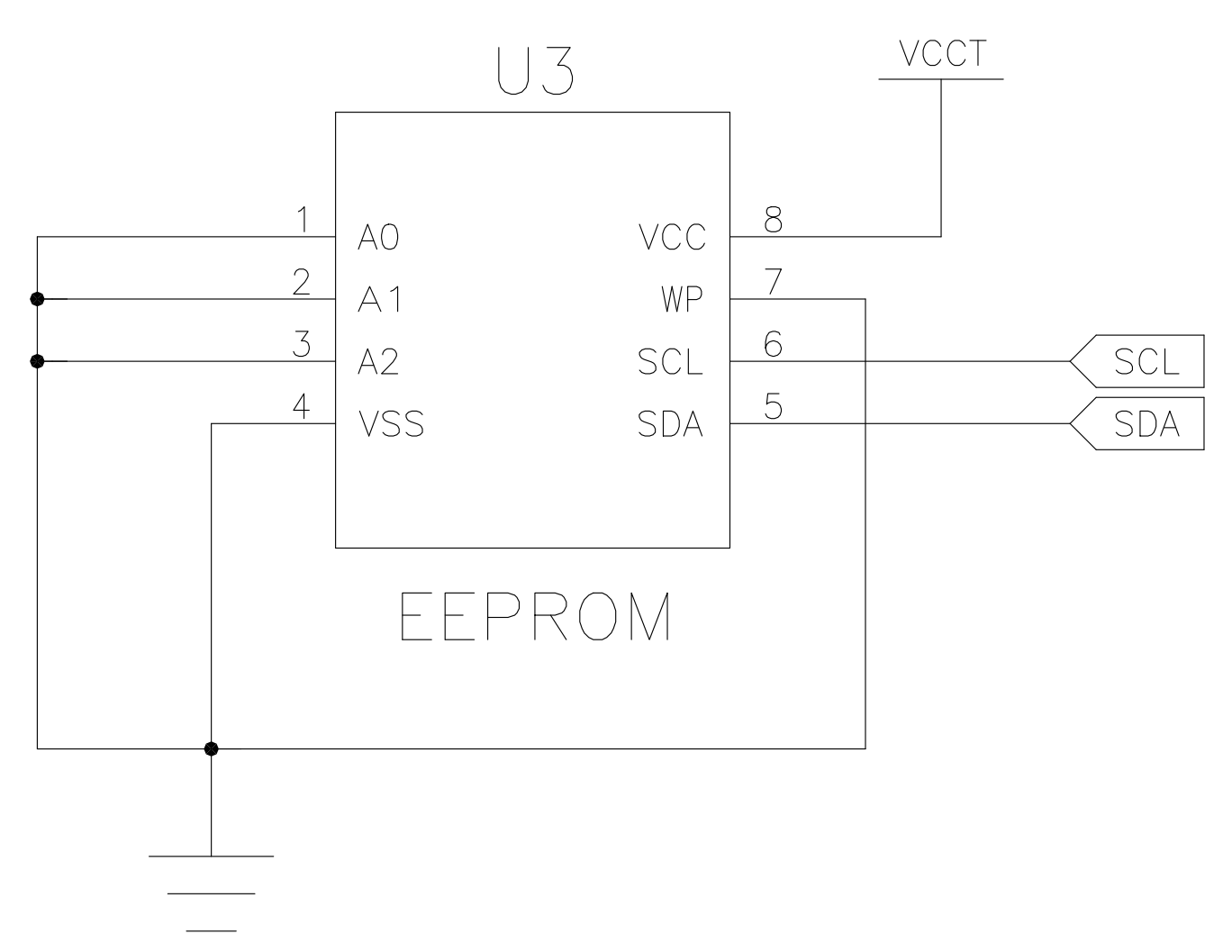
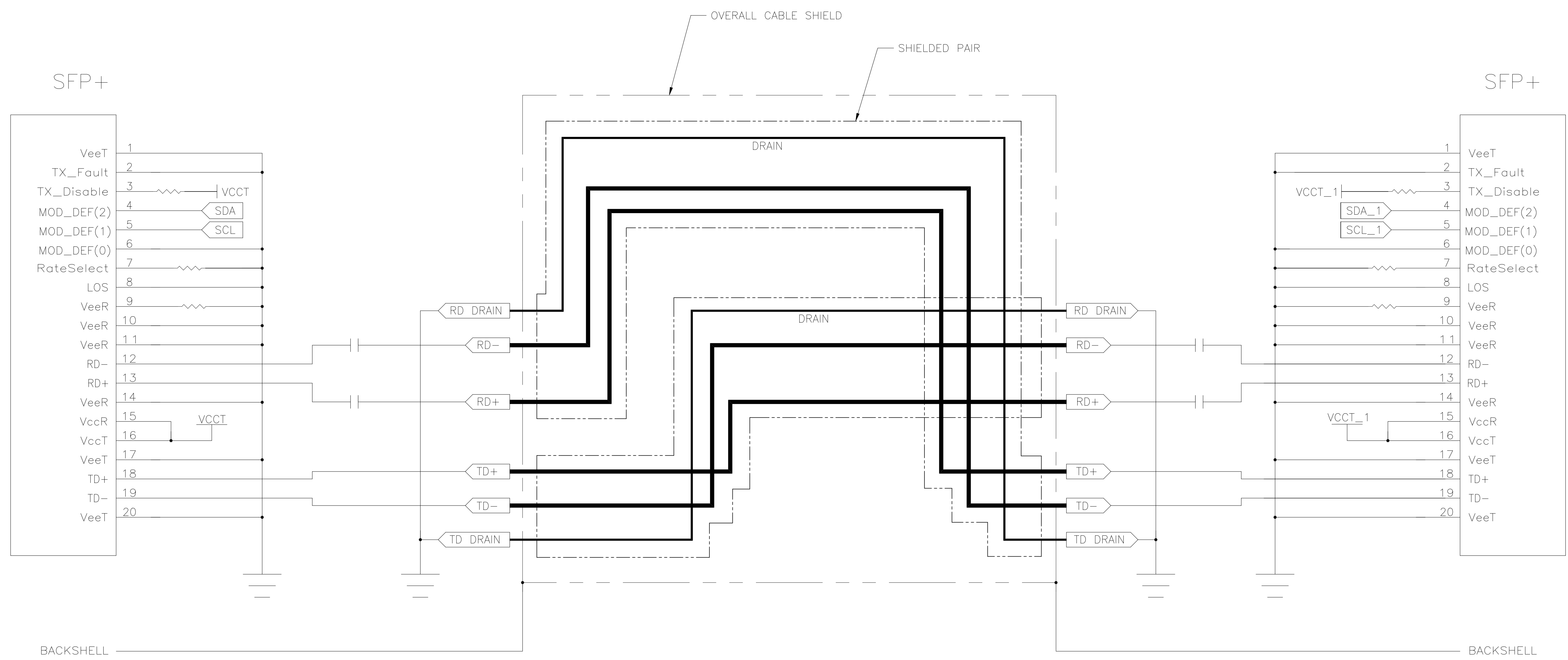

| | | | |
|--|--|-------------------------------|---|
| THIS DRAWING IS A CONTROLLED DOCUMENT. | | DIN T.SMITH 18MAR2010 | TE Connectivity Ltd. |
| DIMENSIONS: mm | | CHK C.ADAMS 18MAR2010 | |
| TOLERANCES UNLESS OTHERWISE SPECIFIED: 0. PLC ± . 1. PLC ± . 2. PLC ± . 3. PLC ± . 4. PLC ± . ANGLES ± . | | APP'D C.ADAMS 18MAR2010 | NAME CABLE ASSY,24 AWG,SFP+ TO SFP+ NI_PLATED |
| MATERIAL | | WEIGHT | RESTRICTED TO |
| FINISH | | SCALE 1:1 | SHEET 2 OF 2 REV F |
| CUSTOMER DRAWING | | SIZE A1 | DRAWING NO. 00779 |
| | | WEIGHT | DRAWING NO. 2127934 |