

REVISIONS				
P.	LTN.	DESCRIPTION	DATE	APVD.
A	ECO-14-011988		05AUG2014	YS TD
A1	ECO-15-002890		24FEB2015	YS TD
A2	ECR-17-012831		08AUG2017	AH CK

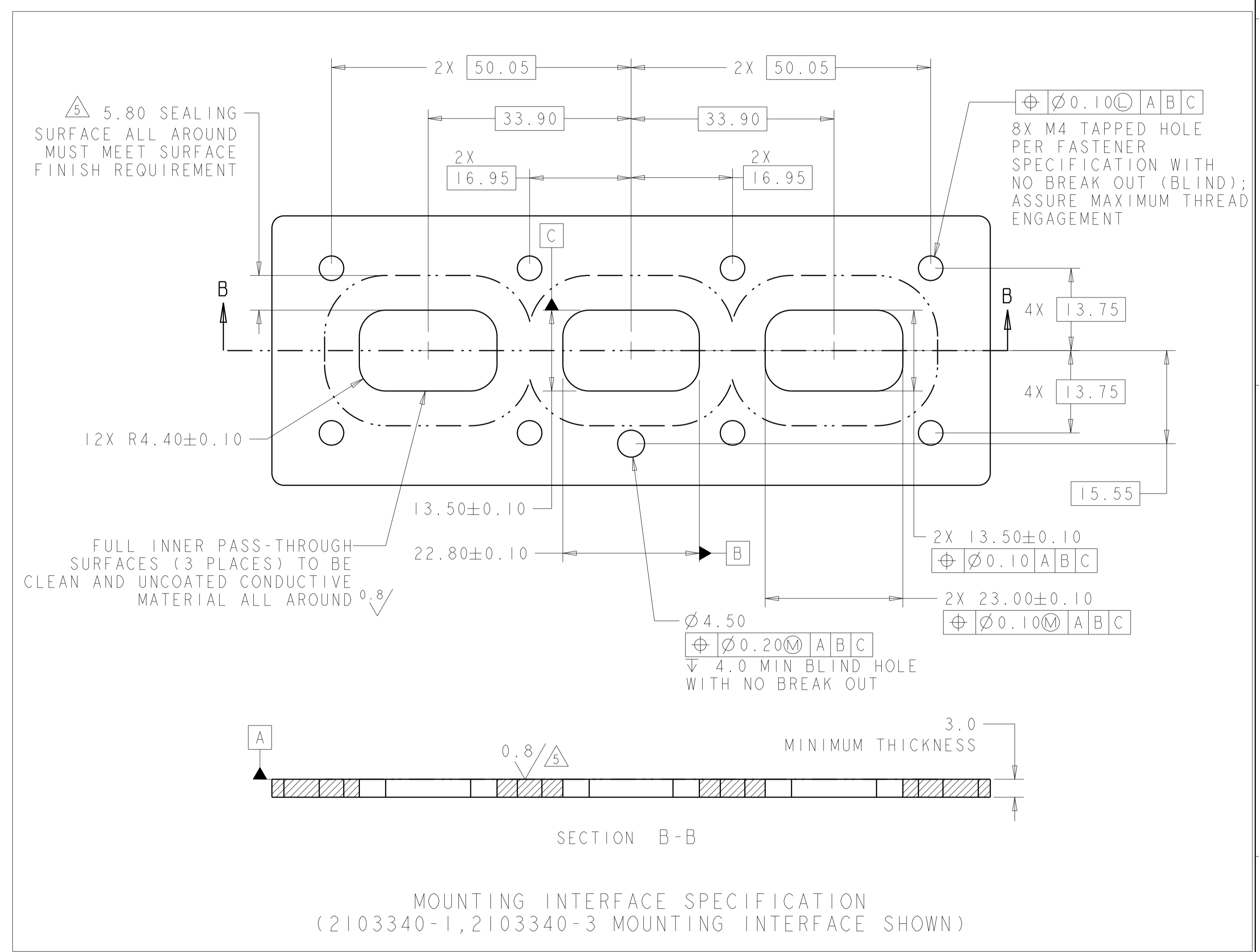

- △ IDENTIFICATION MARKING ON THIS SURFACE CONTAINS ASSEMBLY P/N AND DATE CODE (YYDD). TEXT ORIENTATION, SIZE, AND LOCATION CAN VARY AS LONG AS TEXT IS ON SURFACE SHOWN AND READABLE.
- △ SHIELD SEAM CAN BE POSITIONED AS SHOWN OR ROTATED 180° FROM POSITION SHOWN.
- 3. NOTE DELETED
- △ THESE DIMENSIONS DEFINE FASTENER SIZE LIMITS FOR PROPER COMPONENT FUNCTIONALITY. END USER MUST ENSURE FASTENER AND/OR WASHER DIAMETER IS 8.6 MM MIN FOR PROPER RETENTION. THESE ARE NOT PRODUCT FEATURES - NO INSPECTION REQUIRED FOR THESE ITEMS.
- △ SURFACE FINISH APPLIES IN THIS AREA
- 6. USE WITH INNER HOUSING 2103245-X (2P) OR 2103321-X (3P)

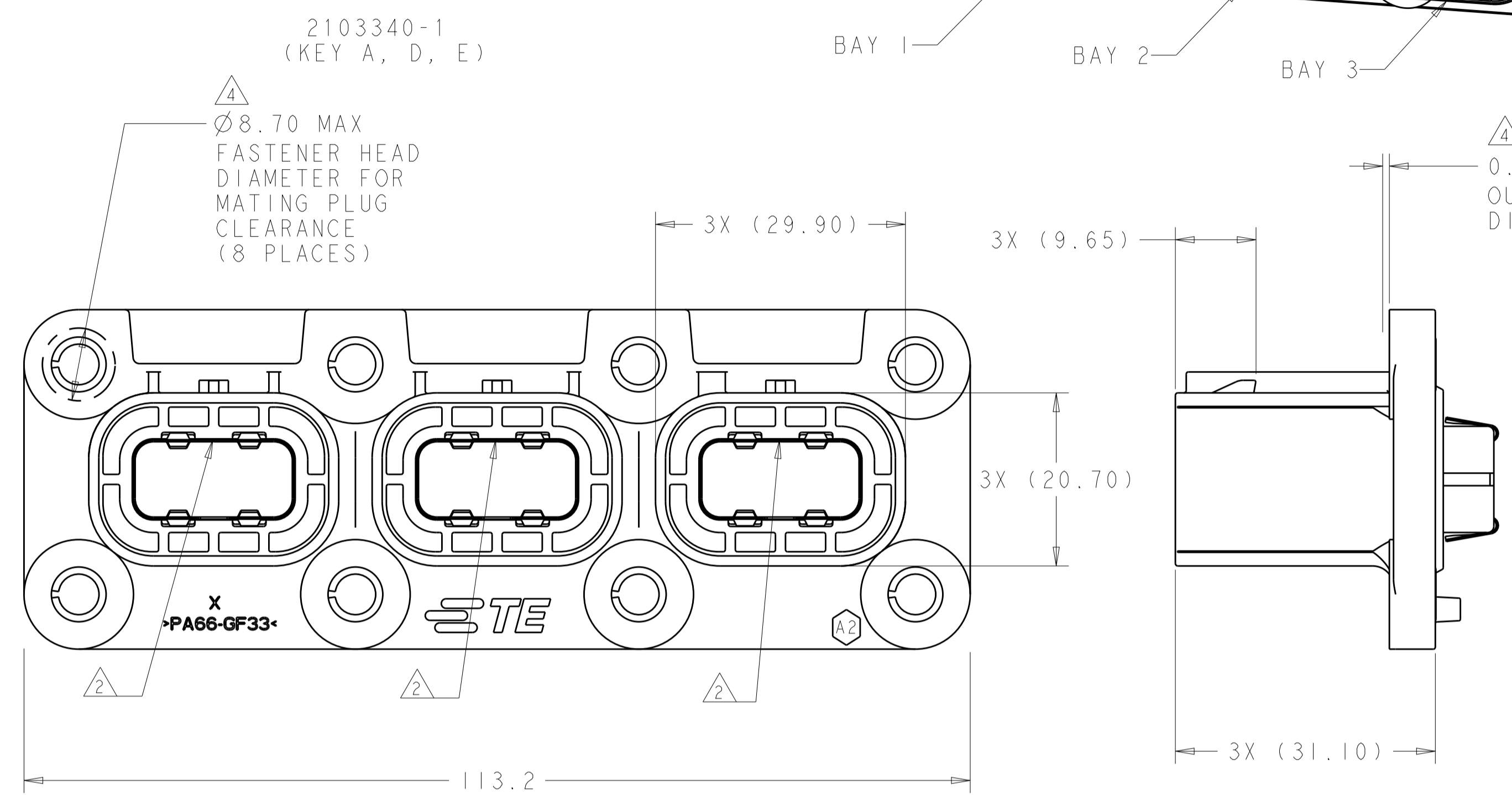
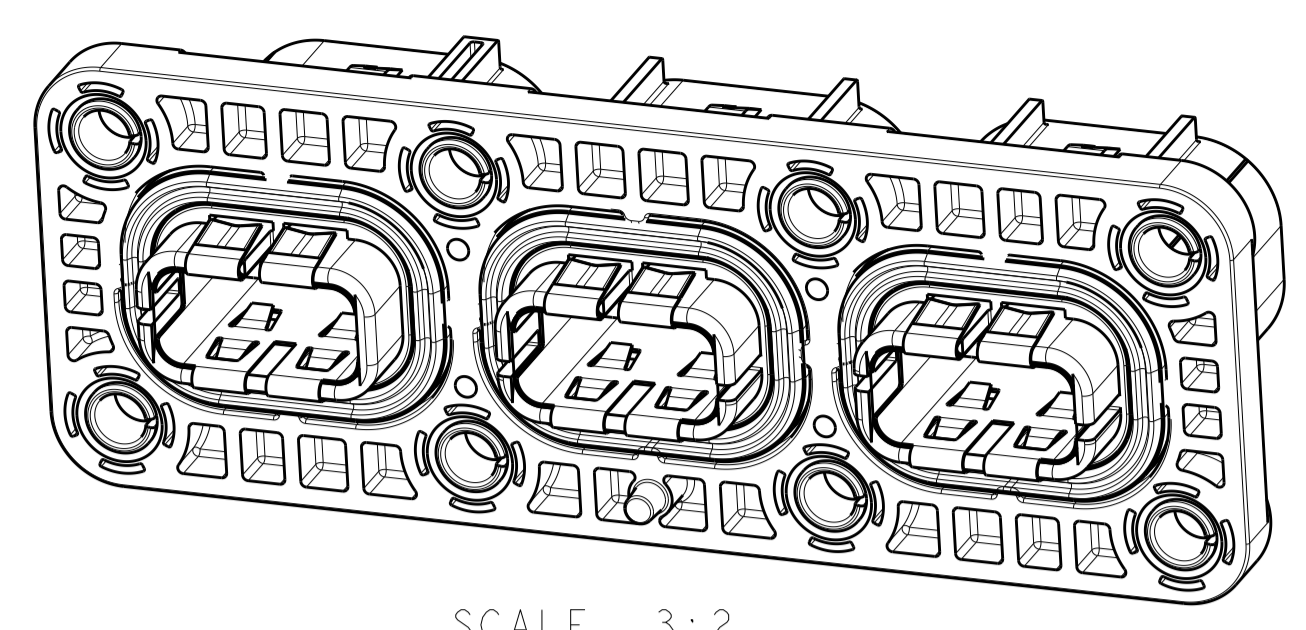
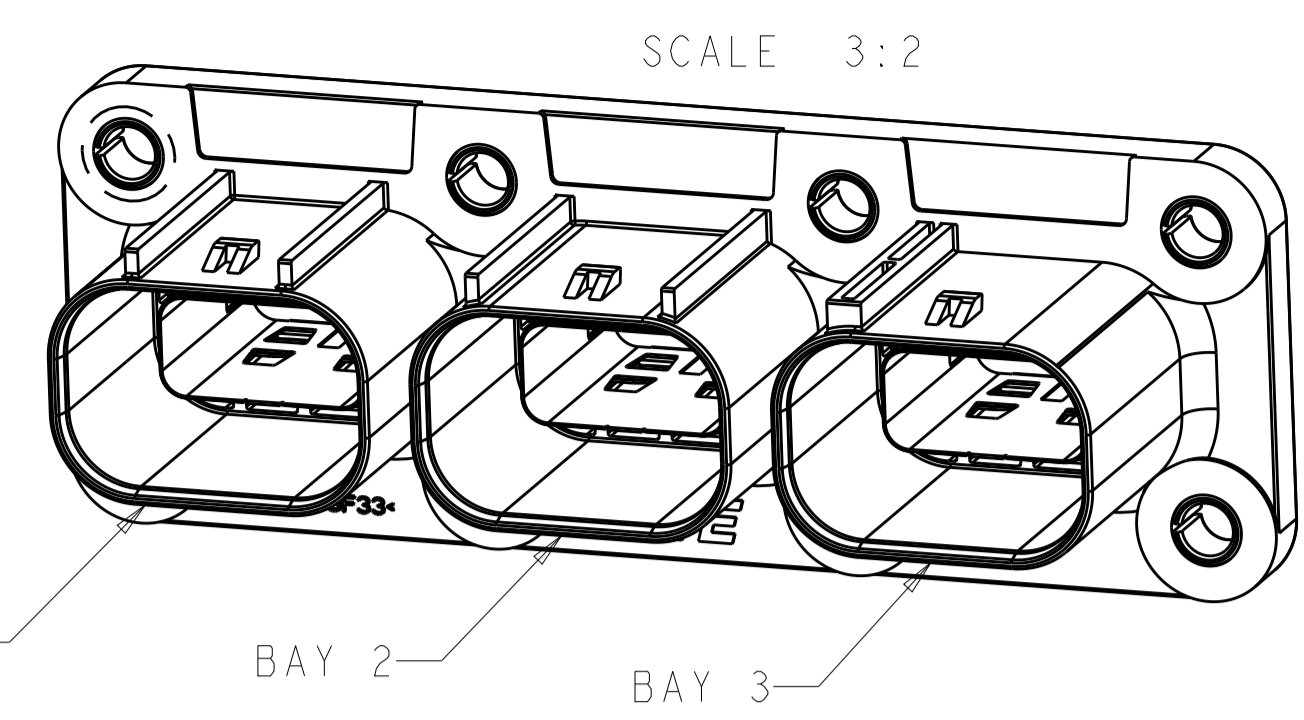
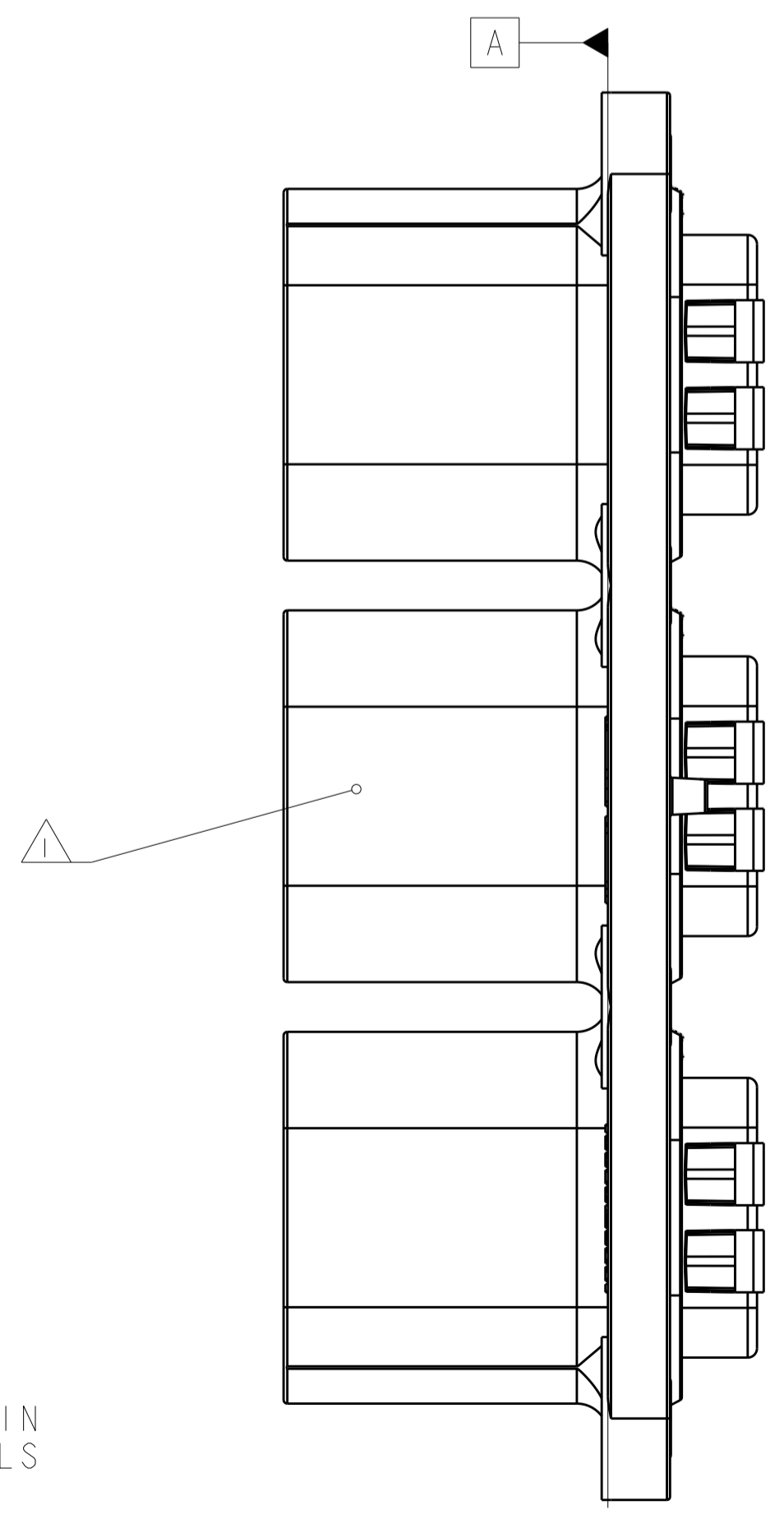

MOUNTING INTERFACE SPECIFICATION  
 (2103340-1, 2103340-3 MOUNTING INTERFACE SHOWN)

△ DATE CODE TO REPRESENT YEAR AND WEEK OF MANUFACTURE. TO OBTAIN WEEK OF MANUFACTURE, ADD READINGS OF BOTH LEFT AND RIGHT DIALS (E.G. 30 AND 7 MEANS 37TH WEEK). YEAR CODE IS THE INNER NUMBER ON ONE OF THE DIALS.

A, D, E	2103340-3
A, D, E	2103340-1
INDEX (BAY 1, 2, 3)	TE P/N

THIS DRAWING IS A CONTROLLED DOCUMENT.		OWN	T. DEWILTE	20JUN2012
DIMENSIONS:		CHK	T. DEWILTE	20JUN2012
mm	0 PLC ±0.50	APVD	T. DEWILTE	20JUN2012
	1 PLC ±0.50	PRODUCT SPEC		
	2 PLC ±0.15	APPLICATION SPEC		
	3 PLC ±0.05	SIZE		
	4 PLC ±	CAGE CODE		
	ANGLES ±	DRAWING NO		
MATERIAL	FINISH	RESTRICTED TO		
		A100779C=2103340		
Customer Drawing		SCALE	2:1	SHEET 1 OF 2

REVISIONS				
P.	LTN	DESCRIPTION	DATE	APVD
-	-	SEE SHEET 1	-	-

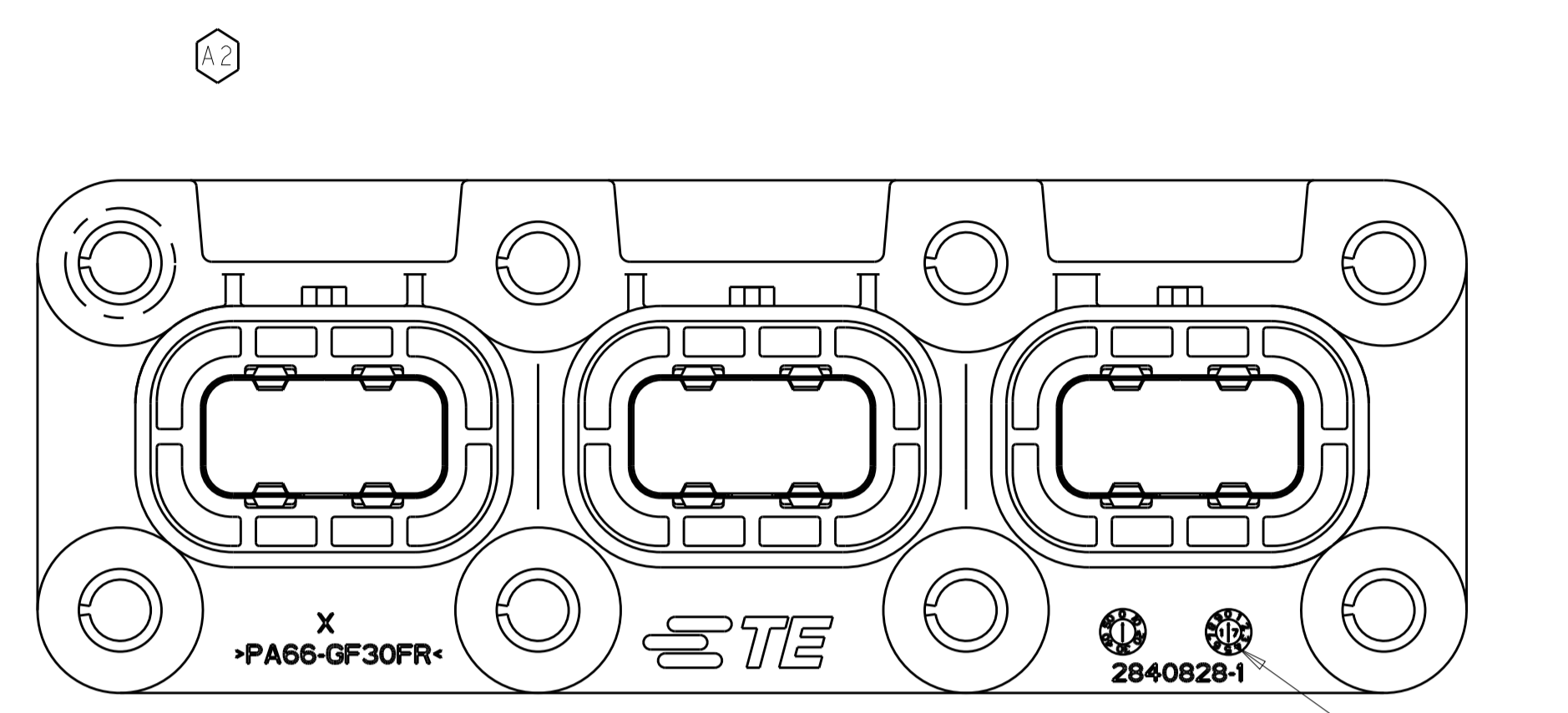
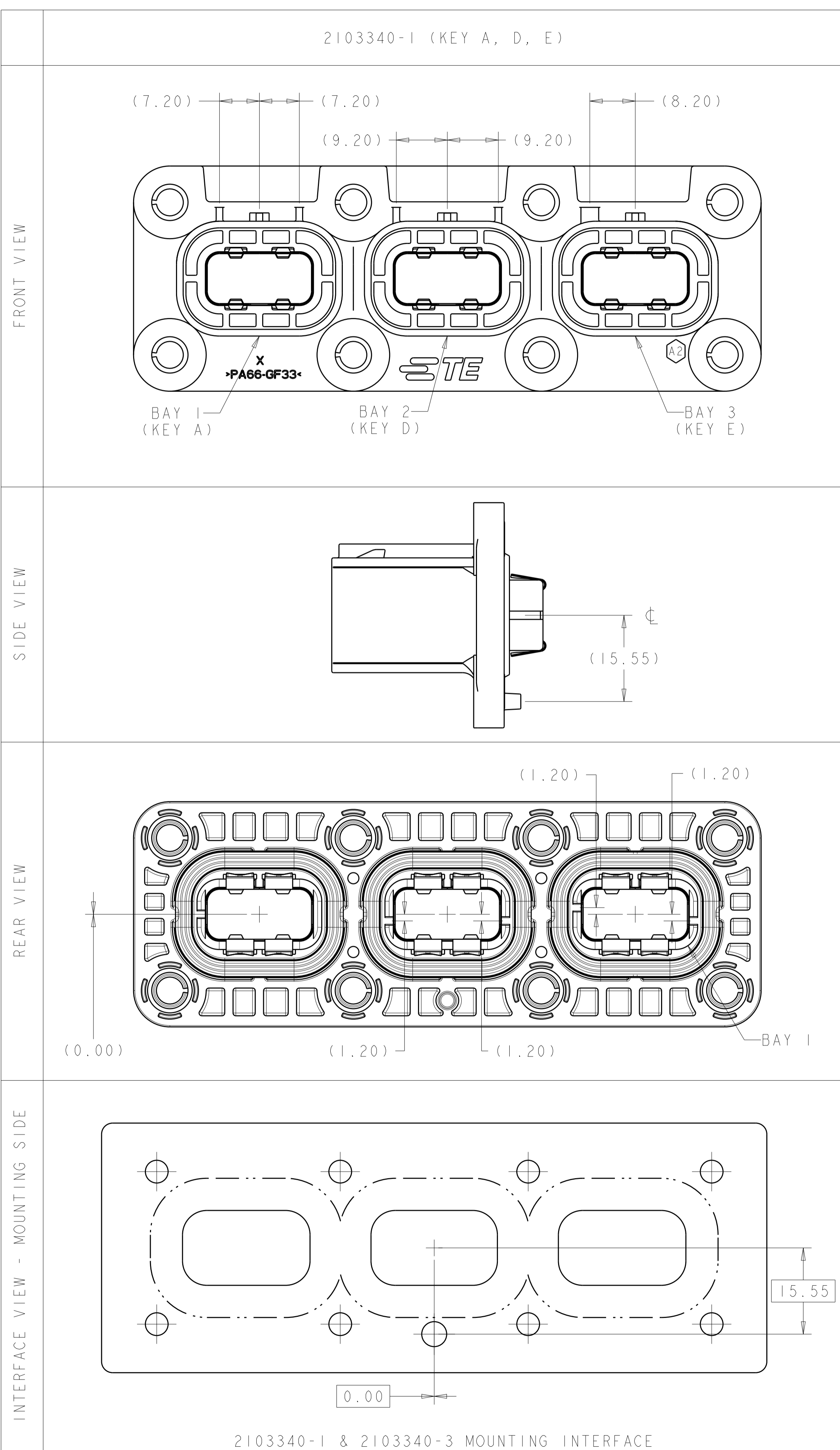

A, D, E	2103340-3
A, D, E	2103340-1
INDEX (BAY 1, 2, 3)	TE P/N

THIS DRAWING IS A CONTROLLED DOCUMENT.

DIMENSIONS:	TOLERANCES UNLESS OTHERWISE SPECIFIED:	0 PLC ±0.50	1 PLC ±0.50	2 PLC ±0.15	3 PLC ±0.05	4 PLC ±	ANGLES ±	FINISH
mm								

OWN	T. DEWILTE	20JUN2012
CHK	T. DEWILTE	20JUN2012
APVD	T. DEWILTE	20JUN2012
PRODUCT SPEC		
APPLICATION SPEC		
WEIGHT		
CUSTOMER DRAWING		

NAME	3 BAY HEADER ASSY, HVA280	
SIZE	CAGE CODE	DRAWING NO
A1	00779	C=2103340
RESTRICTED TO		
SCALE	2:1	SHEET 2 OF 2
REV	A2	

STE TE Connectivity