

THIS DRAWING IS UNPUBLISHED. RELEASED FOR PUBLICATION MAY, 2017.  
 © COPYRIGHT 2017 By TE Connectivity ALL RIGHTS RESERVED.

REVISIONS					
P	LTR	DESCRIPTION	DATE	DWN	APVD
	A	NEW DRAWING	23MAR2016	KR	KM
	B	DRAWING FORMAT UPDATE	11MAY2017	GK	KM

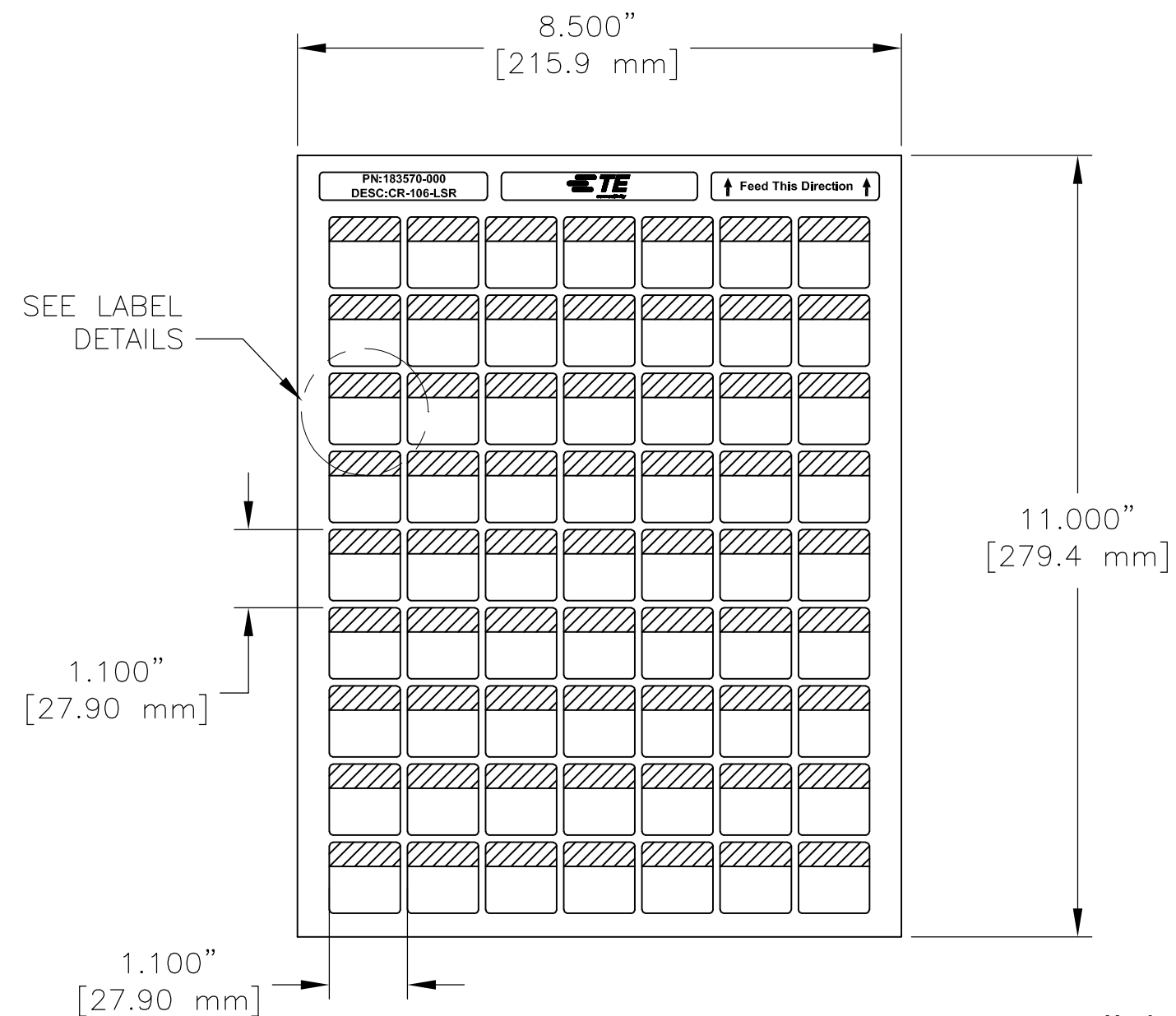

LABEL DETAILS

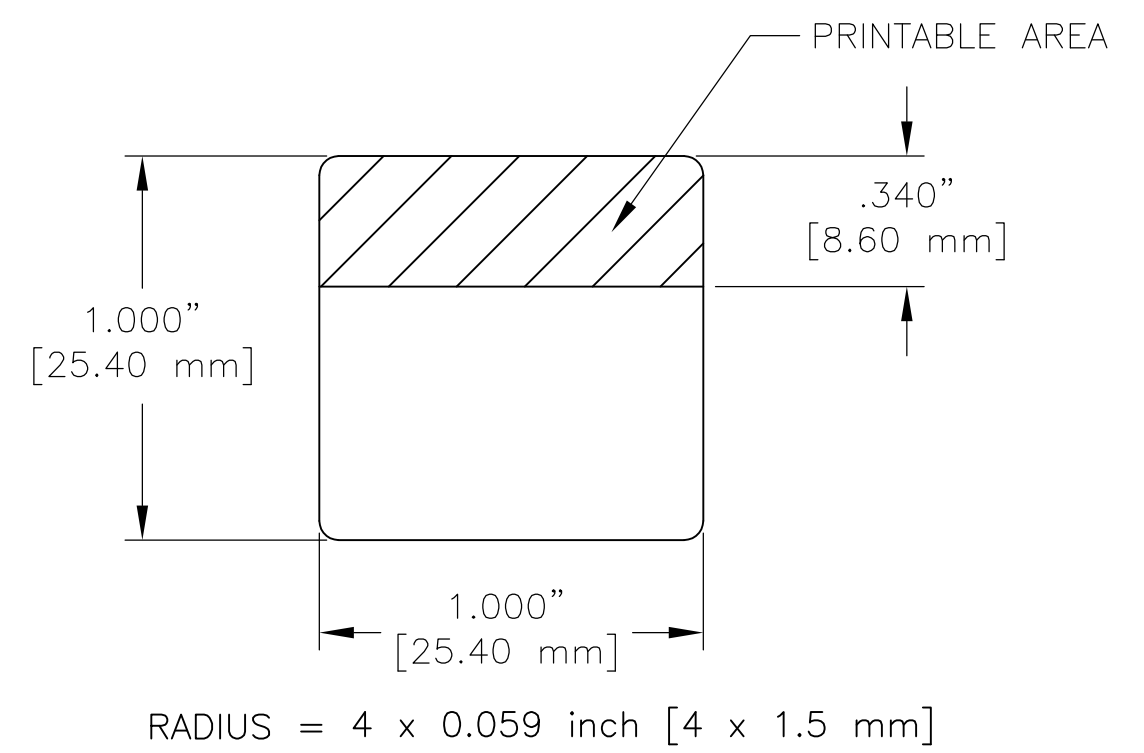

**LABEL ACROSS: 7**  
**PACKAGE QTY: 2,520**

All dimensions in INCHES[mm]

**TE PN: 183570-000**

MATERIAL	CLEAR POLYESTER FILM
ADHESIVE TYPE	PERMANENT
PRINT	WHITE PRINTABLE AREA AND HEADER WITH TE LOGO AND INFORMATION LINE IN WHITE COLOUR ON CLEAR FILM
REALIZATION	63 LABELS PER SHEET

TOLERANCES INCH [mm]	
LABEL HEIGHT:	±.012 [0.3]
LABEL WIDTH:	±.012 [0.3]
WEB WIDTH:	±.031 [0.8]
VERTICAL REPEAT:	±.031 [0.8]*
HORIZONTAL REPEAT:	±.031 [0.8]*
PRINT POSITIONING:	±.031 [0.8]*
LEFT MARGIN:	±.016 [0.4]
QUANTITY:	-0 % +2 %
*NON ACCUMULATING	

THIS DRAWING IS A CONTROLLED DOCUMENT.	
DIMENSIONS: INCHES [mm]	TOLERANCES UNLESS OTHERWISE SPECIFIED:
	0 PLC ± -
	1 PLC ± .1
	2 PLC ± .050
	3 PLC ± .020
	4 PLC ± 1/8"
ANGLES ± -	
MATERIAL: SEE TABLE	FINISH: GLOSSY

DWN	11MAY2017		TE Connectivity				
CHK	11MAY2017		NAME				
K. MUNZ			CR-106-LSR				
K. MUNZ			LSR LASER PRINTABLE SELF-LAMINATING LABELS				
APVD	11MAY2017	PRODUCT SPEC	NAME	SIZE	CAGE CODE	DRAWING NO	RESTRICTED TO
K. MUNZ		-	-	A3	00779	C-183570-000	-
K. MUNZ		APPLICATION SPEC	NAME	SCALE	SHEET	REV	
K. MUNZ		-	-	NTS	1 OF 1	B	
K. MUNZ		WEIGHT	NAME	CUSTOMER DRAWING			
K. MUNZ		-	-				