

LOC	DIST	REVISIONS					
AF	50	P	LTR	DESCRIPTION	DATE	DWN	APVD
		A		REVISED PER 0G3A-0954-04	01DEC04	MF	GJ

- 1 DIMENSIONS SPECIFIED MAY VARY PER CUSTOMER APPLICATION, DO NOT TOOL WITHOUT TYCO ELECTRONICS REVIEW AND APPROVAL.
- 2 TYCO ELECTRONICS REQUIRES THE FOLLOWING INFORMATION IN ORDER TO APPROVE THE CUSTOMERS APPLICATION DRAWING MAGNET WIRE RANGE, LEAD WIRE RANGE AND INSULATION THICKNESS.
- 3 MAGNET WIRE COIL MUST NOT EXCEED HEIGHT OF MAGNET WIRE SLOT AS SHOWN UNLESS PROVISIONS ARE MADE TO KEEP "FINISH" WIRE FLAT AGAINST BASE OF WIRE SLOT.
- 4 MATERIAL RECOMMENDED: NYLON 6/6 AND NYLON 6/6 30% GLASS FILLED. OTHER MATERIALS ARE ACCEPTABLE HOWEVER, CONSULT TYCO ELECTRONICS FOR SPECIFICATIONS.
- 5 30 AWG. (Ø .01 [0.26]) WIRE AND FINER REQUIRES WIRE WRAP POST INSTEAD OF TRIM POST. SEE SPEC. DRW. #1601447.
- 6 MUST MAINTAIN SLOT THICKNESS (.0235) [0.60] INCLUDING DRAFT ANGLE FROM BOTTOM OF POCKET TO .015 [0.38] MINIMUM ABOVE BASE OF WIRE SLOT. (.029 [0.74] MAX. THICKNESS AT TOP).
- 7 WHENEVER POSSIBLE, POCKET PITCH TO MATCH TERMINAL PITCH. MINIMUM PITCH TO BE .197 [5.00].
- 8 .060 [1.52] MIN. WALL THICKNESS RECOMMENDED ON TRIM POST SIDE WHEN WIRE TRIMMING IS REQUIRED.
- 9 SIZE THIS SLOT FOR LARGEST WIRE DIA. CONSULT MOLD VENDOR IF SMALLER THAN .020 [0.51] IS TO BE SPECIFIED.
- 10 REFER TO TABLE. CONSULT TYCO ELECTRONICS IF WIRE SIZE TO BE USED, OVERLAP THE RANGES SHOWN.
- 11 SLOT DEPTH DIMENSIONS ARE FOR CONNECTING ONE MAGNET WIRE WITH A MOVING BEAM SIAMEZE CONTACT. CONSULT TYCO ELECTRONICS FOR BIFILAR (2 WIRE) CONNECTIONS.

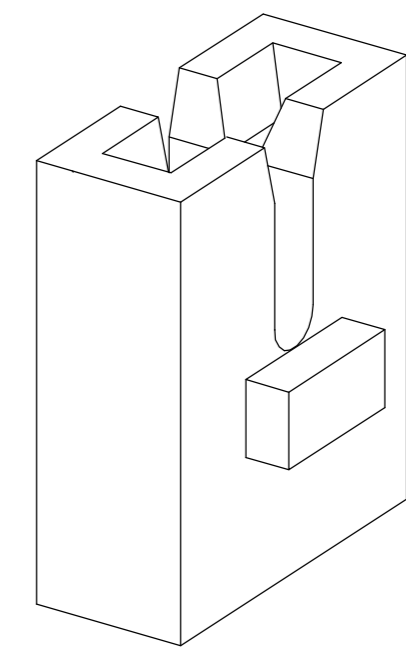
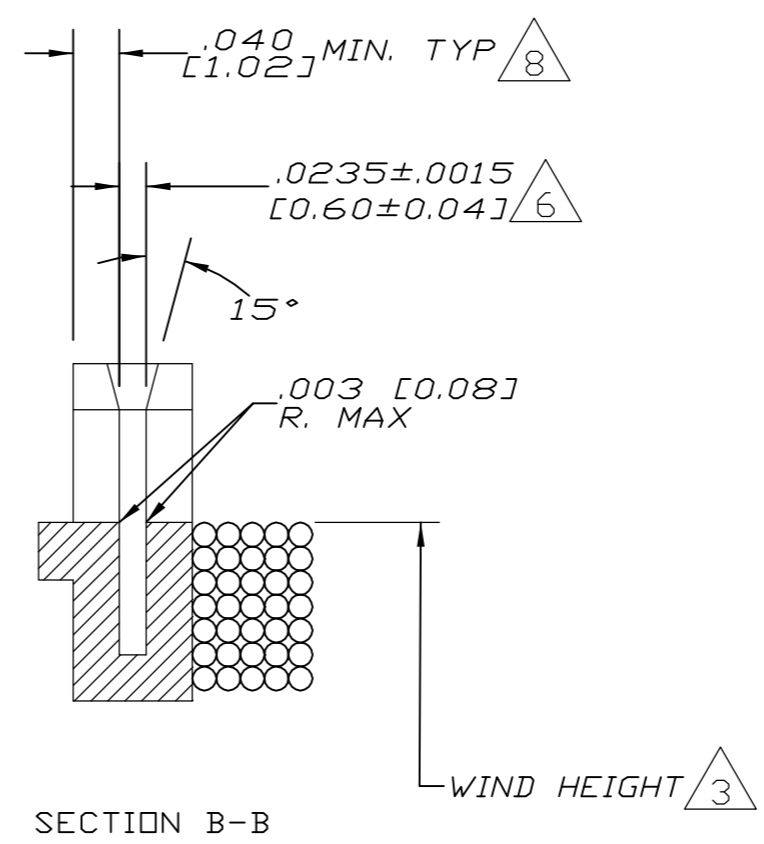
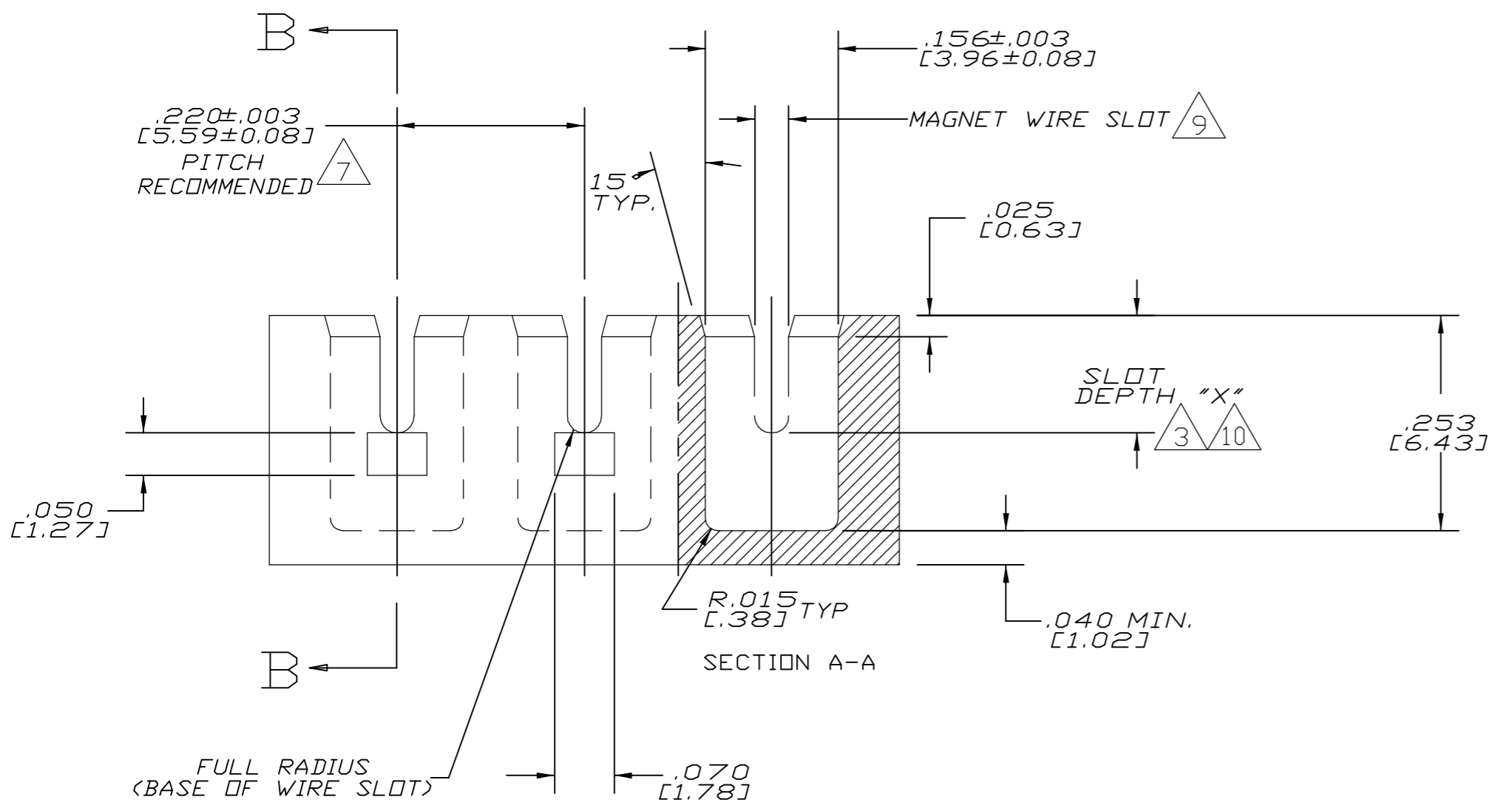
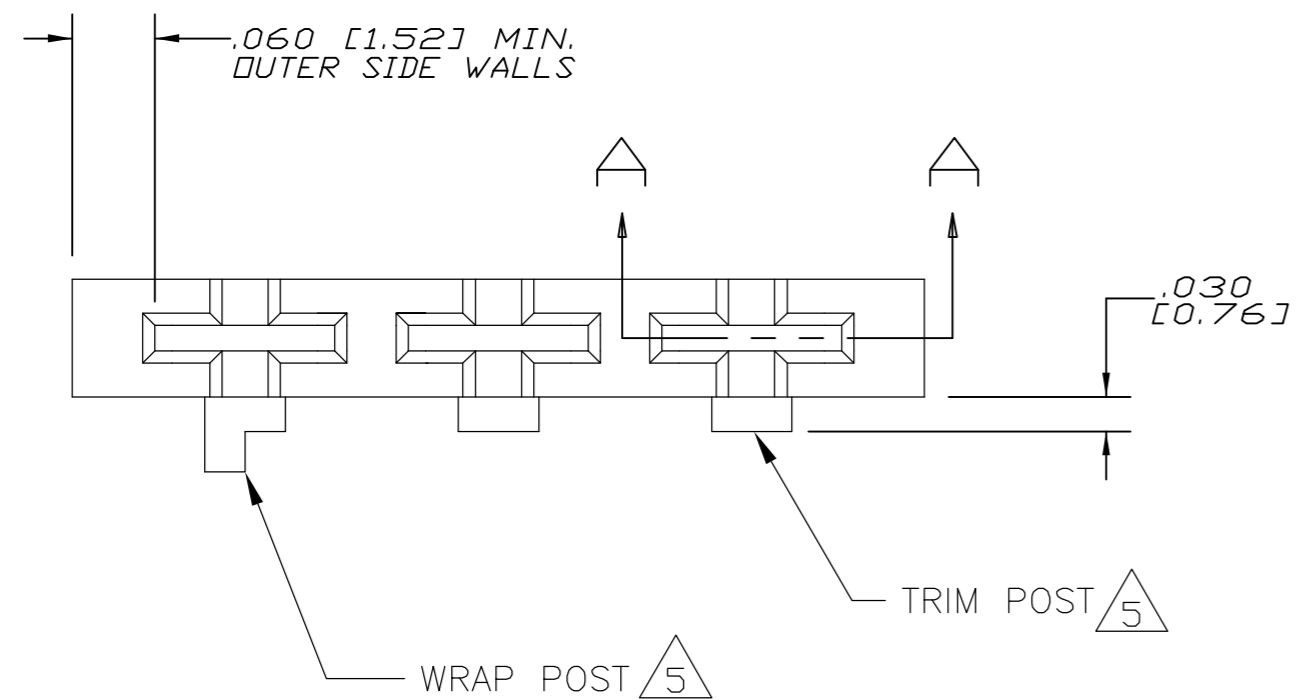

MAGNET WIRE SIZE AWG [mm DIA]	SLOT DEPTH "X" ±.003 [±0.08] 11
#18-#21.5 [1.02-0.69]	.158 [4.01]
#22-#25.5 [0.65-0.43]	.146 [3.71]
#26-#29.5 [0.41-0.27]	.138 [3.51]
#30-#33.5 [0.25-0.17]	.133 [3.38]
#34-#36 [0.16-0.13]	.130 [3.30]

THIS DRAWING IS A CONTROLLED DOCUMENT.		DWN 05APR2002 MICHAEL S. FEHER	tyco Tyco Electronics Corporation Harrisburg, Pa 17105-3608	
DIMENSIONS: INCHES		CHK 05APR2002 GENE JACONO	NAME KURT A. RANDOLPH	
TOLERANCES UNLESS OTHERWISE SPECIFIED:		APVD 05APR2002 KURT A. RANDOLPH	PRODUCT SPEC	
0 PLC ± -		APPLICATION SPEC		
1 PLC ± -		408-8629		
2 PLC ± .01 [0.25]		WEIGHT -		
3 PLC ± .005 [0.13]		SIZE A2 CAGE CODE 00779 DRAWING NO C=1601434		
4 PLC ± .0010 [0.026]		RESTRICTED TO -		
ANGLES ± 2°		SCALE 6:1 SHEET 1 OF 1 REV A		
MATERIAL 4	FINISH -	CUSTOMER DRAWING		