

THIS DRAWING IS UNPUBLISHED. RELEASED FOR PUBLICATION
 © COPYRIGHT - By - ALL RIGHTS RESERVED.

LOC		DIST		REVISIONS			
P	LTR	DESCRIPTION		DATE	DWN	APVD	
	A	INITIAL RELEASE		2 JUL 12	CAS	MKS	

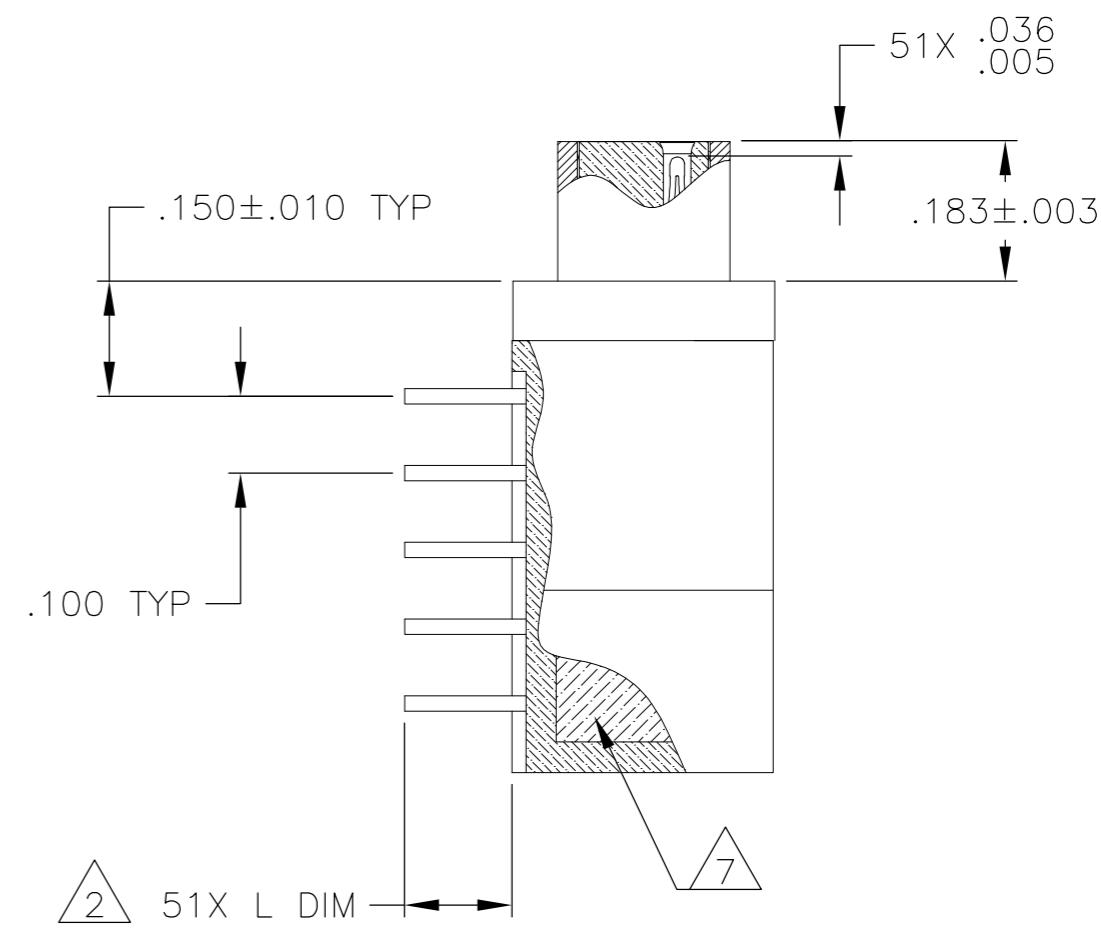
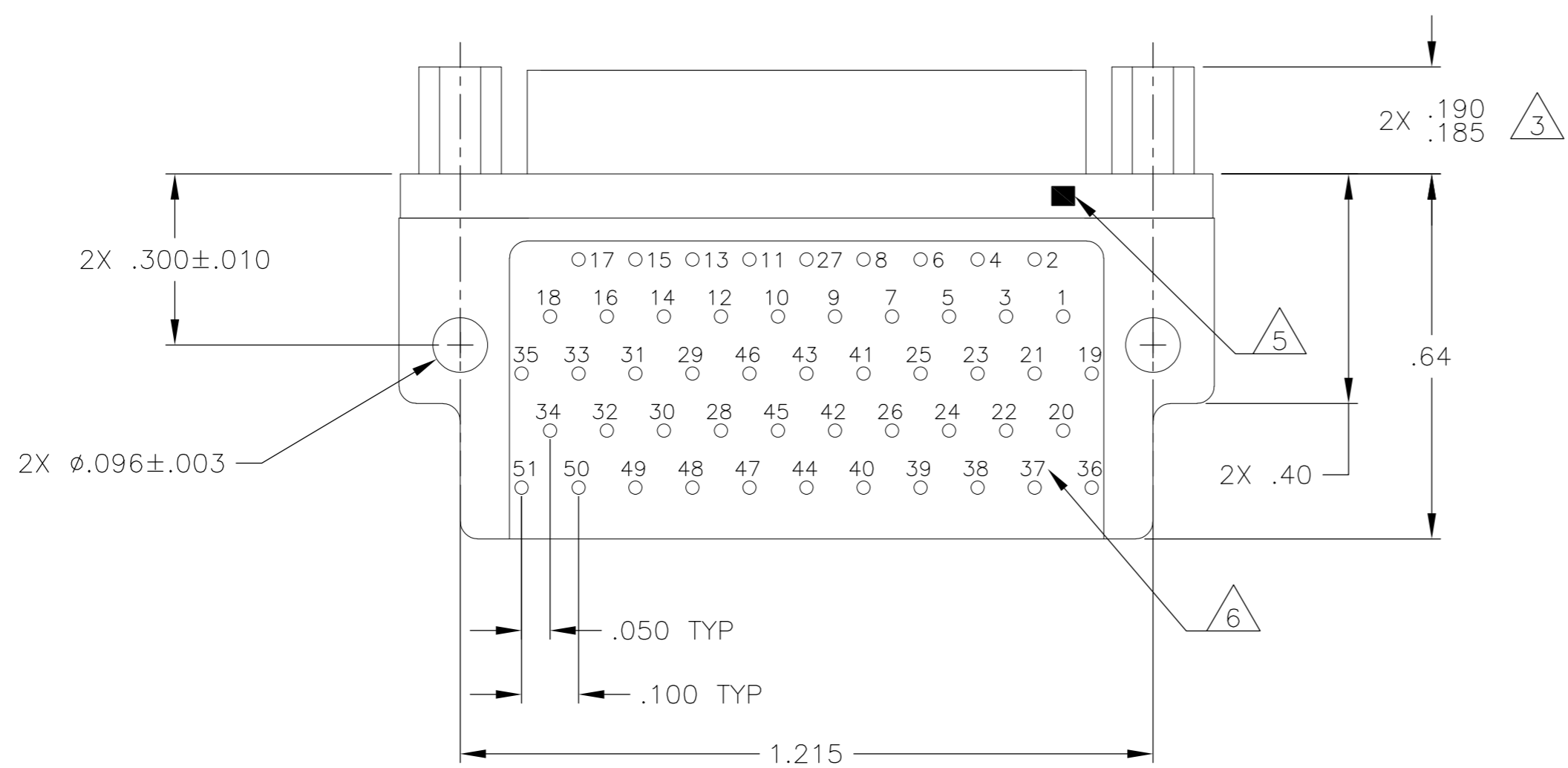
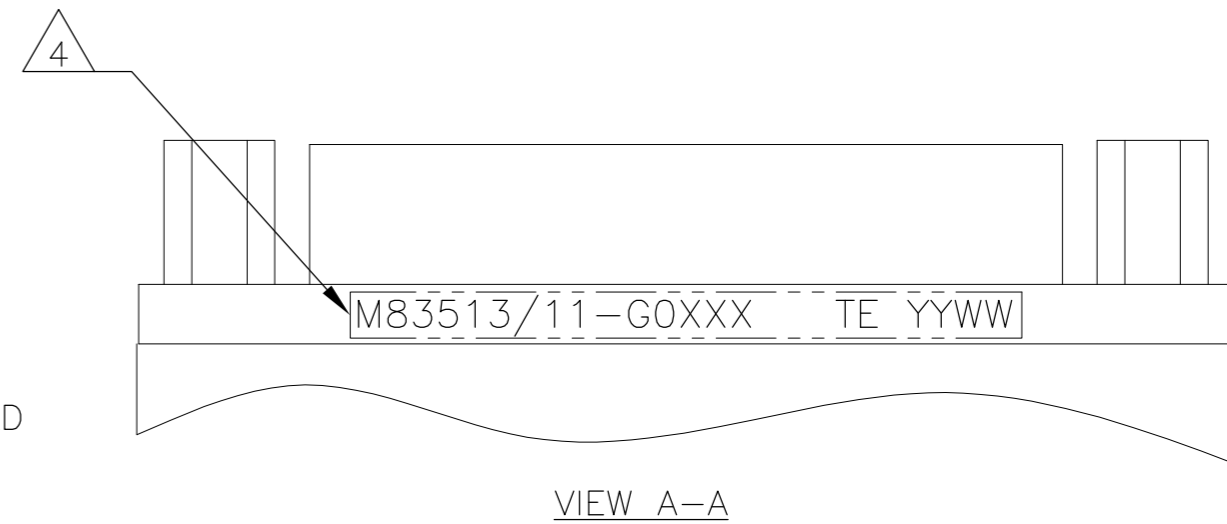
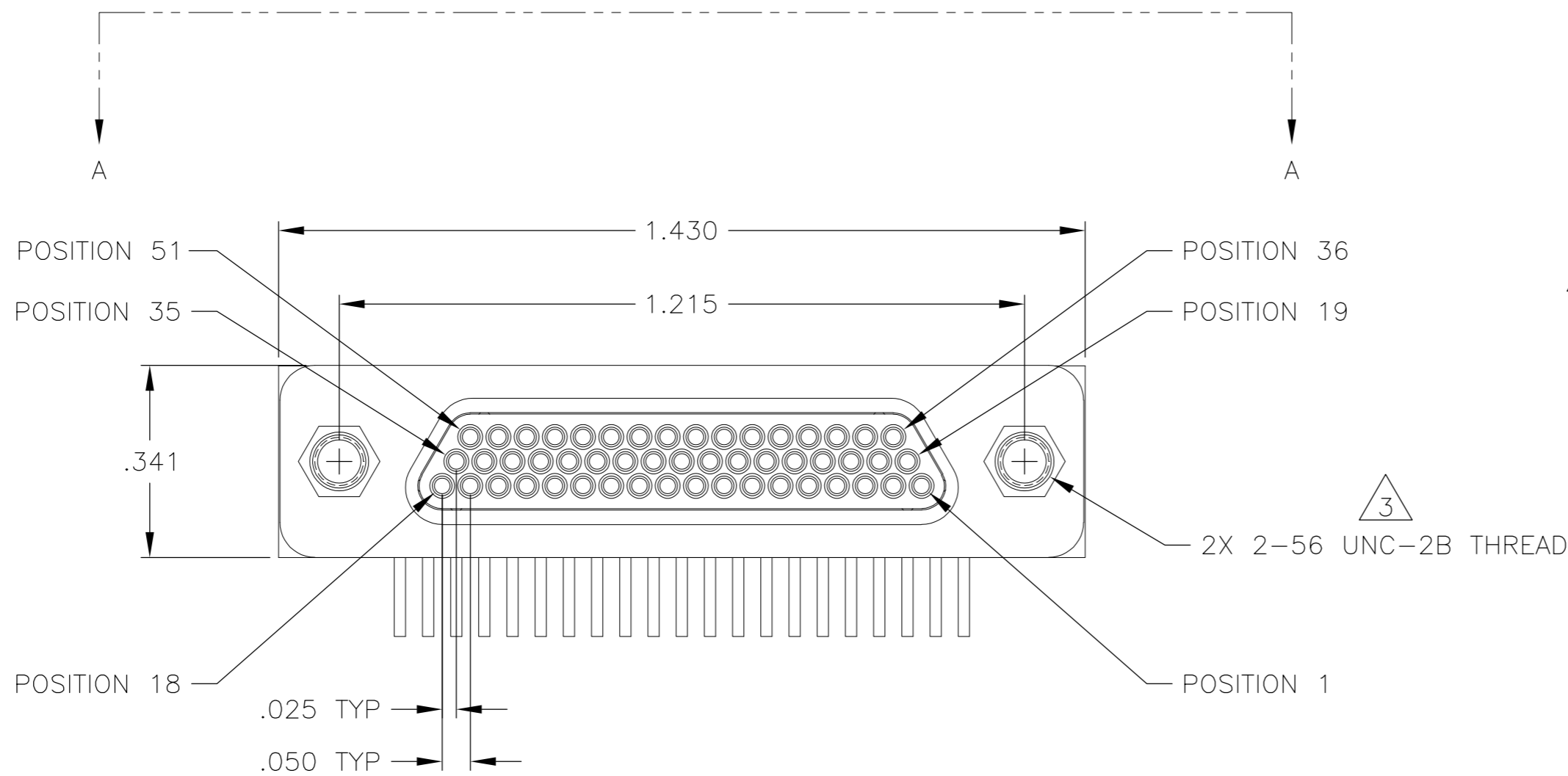

JACKPOSTS OMITTED FOR CLARITY

SEE SHEET 2 FOR NOTES

THIS DRAWING IS A CONTROLLED DOCUMENT.		DWN C SCHOLL 2 JUL 12		
DIMENSIONS: INCHES		CHK M STORRY 2 JUL 12		
TOLERANCES UNLESS OTHERWISE SPECIFIED:		APVD M STORRY 2 JUL 12	NAME PLUG ASSEMBLY, MCKS, RT1 RIGHT ANGLE, PCB MOUNT, 3 ROW, SIZE 51, PER MIL-DTL-83513/11	
0 PLC ± -		PRODUCT SPEC	SIZE A2	CAGE CODE 98278
1 PLC ± -		APPLICATION SPEC	DRAWING NO 1532256	RESTRICTED TO -
2 PLC ± .010			SCALE 4:1	SHEET 1 OF 2
3 PLC ± .005			REV A	
4 PLC ± -				
ANGLES ± 1°				
FINISH SEE NOTES		WEIGHT -	CUSTOMER DRAWING	

THIS DRAWING IS UNPUBLISHED. RELEASED FOR PUBLICATION
 © COPYRIGHT - By - ALL RIGHTS RESERVED.

LOC		DIST		REVISIONS			
P	LTR	DESCRIPTION	DATE	DWN	APVD		
-	-	SEE SHEET 1	-	-	-		

TE PART NUMBER	MIL-DTL-83513 PIN	MCKS DESCRIPTION	SHELL FINISH $\triangle 1$	HARDWARE $\triangle 3$	L DIM $\pm .015$
1532256-1	M83513/11-G01CN	MCKS-C2-B-51PRT1	CADMIUM	NONE	.109
1532256-2	M83513/11-G01CP	MCKS-C2-P-51PRT1	CADMIUM	JACKPOSTS	.109
1532256-3	M83513/11-G01NN	MCKS-N1-B-51PRT1	NICKEL	NONE	.109
1532256-4	M83513/11-G01NP	MCKS-N1-P-51PRT1	NICKEL	JACKPOSTS	.109
1532256-5	M83513/11-G02CN	MCKS-C2-B-51PRT1A	CADMIUM	NONE	.140
1532256-6	M83513/11-G02CP	MCKS-C2-P-51PRT1A	CADMIUM	JACKPOSTS	.140
1532256-7	M83513/11-G02NN	MCKS-N1-B-51PRT1A	NICKEL	NONE	.140
1532256-8	M83513/11-G02NP	MCKS-N1-P-51PRT1A	NICKEL	JACKPOSTS	.140
1532256-9	M83513/11-G03CN	MCKS-C2-B-51PRT1B	CADMIUM	NONE	.172
1-1532256-0	M83513/11-G03CP	MCKS-C2-P-51PRT1B	CADMIUM	JACKPOSTS	.172
1-1532256-1	M83513/11-G03NN	MCKS-N1-B-51PRT1B	NICKEL	NONE	.172
1-1532256-2	M83513/11-G03NP	MCKS-N1-P-51PRT1B	NICKEL	JACKPOSTS	.172

- $\triangle 1$ SHELL MATERIAL: 6061-T6 ALUMINUM
 FINISH OPTIONS:
 ELECTROLESS NICKEL PLATED PER SAE-AMS-C-26074 OR SAE AMS 2404 OR CADMIUM PLATED PER SAE-AMS-QQ-P-416 WITH YELLOW CHROMATE
 INSULATOR: LIQUID CRYSTAL POLYMER (LCP)
 HARDWARE: 300 SERIES STAINLESS STEEL
 TB BOX: POLYPHENYLENE SULFIDE (PPS) AND EPOXY POTTING
- $\triangle 2$ TERMINATION: 24AWG GOLD PLATED COPPER WIRE, Sn63Pb37 SOLDER DIPPED UP TO MOUNTING SURFACE AT A MINIMUM
- $\triangle 3$ JACKPOST HARDWARE SHALL BE PERMANENTLY INSTALLED AS SHOWN WHEN REQUIRED BY THE MIL PIN. JACKPOST DIMENSIONS AND REQUIREMENTS ARE DEFINED IN MIL-DTL-83513/5.
- $\triangle 4$ CONNECTOR SHALL BE MARKED IN ACCORDANCE WITH METHOD I OF MIL-STD-1285. MARKING SHALL CONTAIN THE MILITARY PIN, CAGE CODE (OR TE), AND DATE CODE. EXAMPLE: M83513/11-GOXXX TE YYWW (WHERE XXX IS PART OF THE PIN SHOWN IN THE "MIL-DTL-83513 PIN" COLUMN OF THE PART NUMBER TABLE, AND YYWW IS THE DATE CODE). THE MARKING MUST BE PRINTED ON THE FLANGE. TEXT HEIGHT SHALL BE .035 INCH MINIMUM.
- $\triangle 5$ POSITION 1 SHALL BE INDICATED BY AN IDENTIFIABLE MARK, LOCATED APPROXIMATELY AS SHOWN ON THE POSITION 1 SIDE OF THE CONNECTOR FLANGE. THIS MARK SHALL BE INCLUDED AS PART OF THE PART MARKING INFORMATION.
- $\triangle 6$ TERMINAL IDENTIFICATION NUMBERS AS SHOWN DO NOT ACTUALLY APPEAR ON THE PART (FOR IDENTIFICATION ONLY)
- $\triangle 7$ EPOXY ENCAPSULATION
- 8 ALL REQUIREMENTS CONFORM TO MIL-DTL-83513/11. SEE MIL-SPEC FOR DETAILED INTERFACE DIMENSIONS AND SUGGESTED PCB LAYOUTS

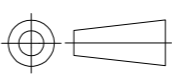
THIS DRAWING IS A CONTROLLED DOCUMENT.		DWN C SCHOLL	2 JUL 12	 TE Connectivity	
DIMENSIONS: INCHES		CHK -	-		
TOLERANCES UNLESS OTHERWISE SPECIFIED:		APVD M STORRY	2 JUL 12	NAME PLUG ASSEMBLY, MCKS, RT1 RIGHT ANGLE, PCB MOUNT, 3 ROW, SIZE 51, PER MIL-DTL-83513/11	
		PRODUCT SPEC -		SIZE A2	
MATERIAL SEE NOTES		APPLICATION SPEC -		CAGE CODE 98278	DRAWING NO 1532256
FINISH SEE NOTES		WEIGHT -		RESTRICTED TO -	
		CUSTOMER DRAWING	SCALE 4:1	SHEET 2 of 2	REV A