

DWG NO. 1102209

THIS DRAWING IS A CONTROLLED DOCUMENT FOR TE INCORPORATED. IT IS SUBJECT TO CHANGE AND THE CONTROLLING ENGINEERING ORGANIZATION SHOULD BE CONTACTED FOR THE LATEST REVISION.

DIESES ZEICHNUNGSDOKUMENT WIRD DURCH TE INCORPORATED KONTROLLIERT. AENDERUNGEN, DIE DEM TECHNISCHEN FORTSCHRITT DIENEN, SIND VORBEHALTEN. DEN JEWEILS LETZTIGUELIGEN AENDERUNGSSTAND ERFAHREN SIE AUF ANFRAGE.

THIS INFORMATION IS CONFIDENTIAL AND IS DISCLOSED TO YOU ON CONDITION THAT NO FURTHER DISCLOSURE IS MADE BY YOU TO OTHER THAN TE PERSONNEL WITHOUT WRITTEN AUTHORIZATION FROM AMP INCORPORATED, HARRISBURG, PA.

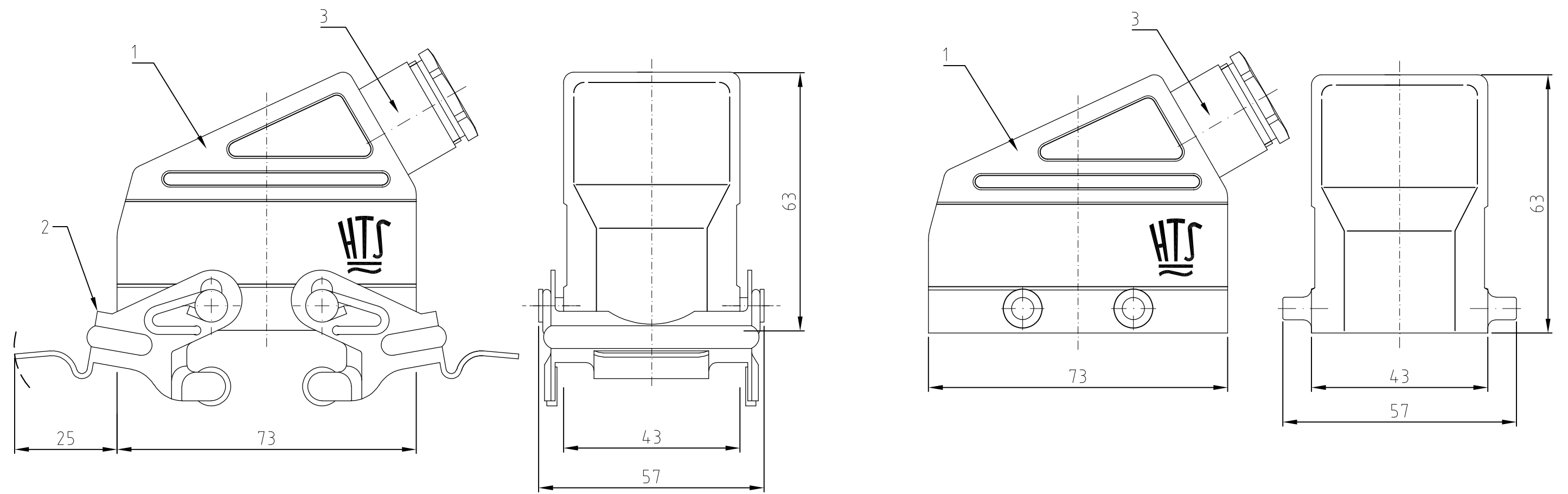

Notes,

- ① Material: Housing: aluminium diecasting alloy
- ② Surface: Varnish- grey
- ③ Varnish on the inside not necessarily

Bemerkungen,

- ① Material: Gehäuse: Alu-Druckguß-Legierung
- ② Oberfläche: Lackierung - grau
- ③ Lackierung im Gehäuseinnere ist nicht notwendig

OBSOLETE													
1	1	Kabelverschraubung rund	Messing	vernickelt	blau/blue	3	PG16						
2	2	VS-Bügel	Stahl	verzinkt	blau/blue	2	-						
1	1	Steckergehäuse HB	aluminium/ALU	-	grey/grau	1	-						
1-6	1-1	DESCRIPTION / BESCHREIBUNG	MATERIAL	SURFACE / OBERFLÄCHE	COLOR / FARBE	ITEM NO. POS.	REMARKS / BEMERKUNGEN						
HB-KF.10.STS.1.16	ORDERING TEXT / BESTELLTEXT	<p>THIS DRAWING IS A CONTROLLED DOCUMENT FOR TE INCORPORATED. IT IS SUBJECT TO CHANGE AND THE CONTROLLING ENGINEERING ORGANIZATION SHOULD BE CONTACTED FOR THE LATEST REVISION. DIESES ZEICHNUNGSDOKUMENT WIRD DURCH TE INCORPORATED KONTROLLIERT. AENDERUNGEN, DIE DEM TECHNISCHEN FORTSCHRITT DIENEN, SIND VORBEHALTEN. DEN JEWEILS LETZTIGUELIGEN AENDERUNGSSTAND ERFAHREN SIE AUF ANFRAGE.</p> <p>DIMENSIONS: DIMENSIONEN: mm</p> <p>TOLERANCES UNLESS OTHERWISE SPECIFIED: ALLGEMEINTOLERANZEN</p> <p>ISO 8015 D. ISO 2768 - mH - E D. DIN 16901 - 14.0</p> <p>0 PLC # 1 PLC # 2 PLC # 3 PLC #</p> <p>ANGLES / WINKEL #</p> <p>FINISH / OBERFLÄCHE / FARBE</p>		DWN SCHNEIDER 09.12.02	Tyco Electronics 53757 Sankt Augustin Germany		<p>NAME</p> <p>HOOD ASSY</p>		RESTRICTED TO NUR FUER				
HB-KF.10.STS-VS.1.16	ORDERING TEXT / BESTELLTEXT			CHK SCHWEIGER 09.12.02			SIZE A3	CAGE CODE 00779	DRAWING NO ZEICHNUNGS-NR. C- 1102209	SCALE MASSSTAB 1:1	SHEET BLATT 1	OF VON 1	REV. A2
				CUSTOMER DRAWING / KUNDENZEICHNUNG									

LOC	A1
DIST	-