

## PIEZO FILM SOLID STATE SWITCHES

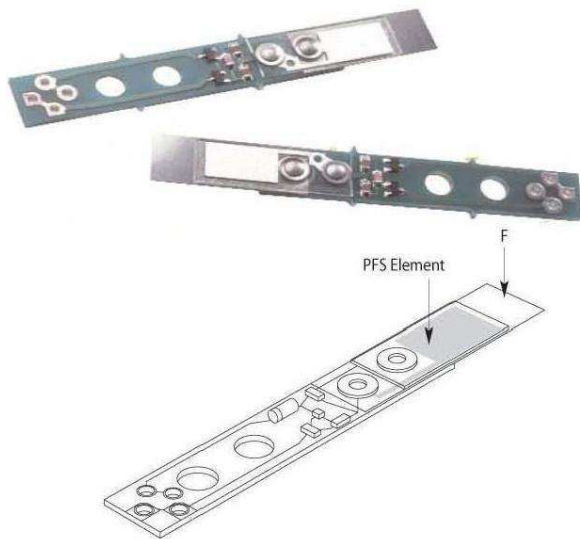

### SPECIFICATIONS

- ◆ **Impact and Momentary Switch**
- ◆ **Digital Output – contact closure**
- ◆ **Robust**
- ◆ **Solderable**
- ◆ **Piezo Film Technology**

The **SW100** is an ideal configuration for impact detection and momentary switch applications. A direct contact force on the top of the stainless steel cantilever beam of the SW100 induces strain on the laminated Piezo Film Sensor (PFS) element. With dynamic strain the PFS element generates an output that activates the built-in transistor, closing the normally open circuit. Once activated, the circuit resembles the closure of a contact switch but without the inherent discontinuity that contact points exhibit because of corrosion, pitting and bouncing.

Thus, the SW100 provides a single digital pulse that is ideal for triggering digital circuits and signal processing. The imperviousness, elasticity and reliability of the PFS element, along with the noise rejection characteristics of the circuit, combine to provide the SW100 with features that suit applications demanding consistent, reliable performance throughout tens of millions of switching cycles.

### FEATURES

- ◆ Digital Output
- ◆ No adjustments required during installation
- ◆ Impervious to moisture, dust and smoke
- ◆ Virtually no maintenance required
- ◆ Long lifetime, greater than 10 million cycles
- ◆ Low profile
- ◆ PCB and beam customization available to fit many applications

### APPLICATIONS

- ◆ Foot pedal / door closure switch
- ◆ Counter of units in assembly line processes
- ◆ Panel switch
- ◆ Toothed gear counter
- ◆ Impact detection and counter for machine-dispensed products
- ◆ Games and toys for impact detection and counting

# PIEZO FILM SOLID STATE SWITCHES

## DIMENSIONS

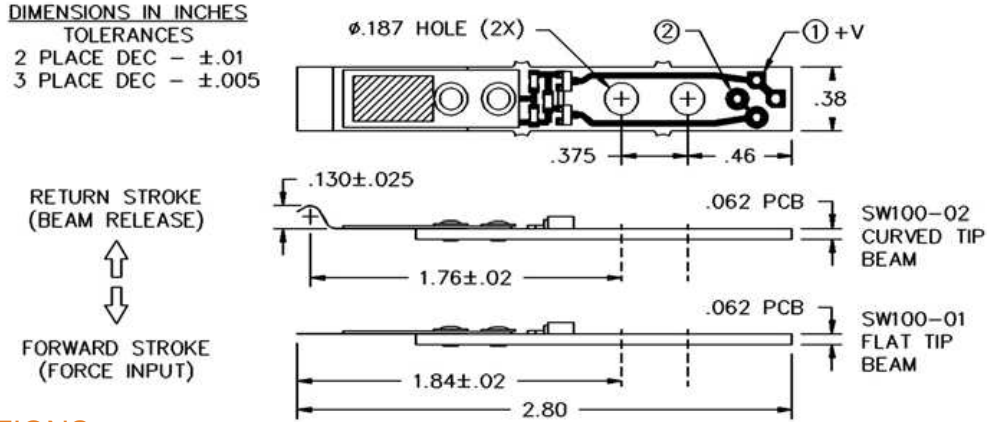

## SPECIFICATIONS

Performance Characteristics (T=25°)	Minimum	Typical	Maximum	Units
Force Input/Beam Tip Deflection	10/0.03	20/0.06	30/0.09	Gram/In
Frequency of Force Input	5	-	60	Hz
Voltage Input	+5.0	-	+50	Volts
Switch Current	+0.5	-	+70	mA
On Resistance	-	7.5	13.5	Ohms
Life	-	-	>>10MM	Cycles
<b>Environmental Characteristics</b>				
Operating Temperature	5	-	60	°C
Operating Humidity	-	-	90% non-cond.	
Storage Temperature	-40	-	60	°C

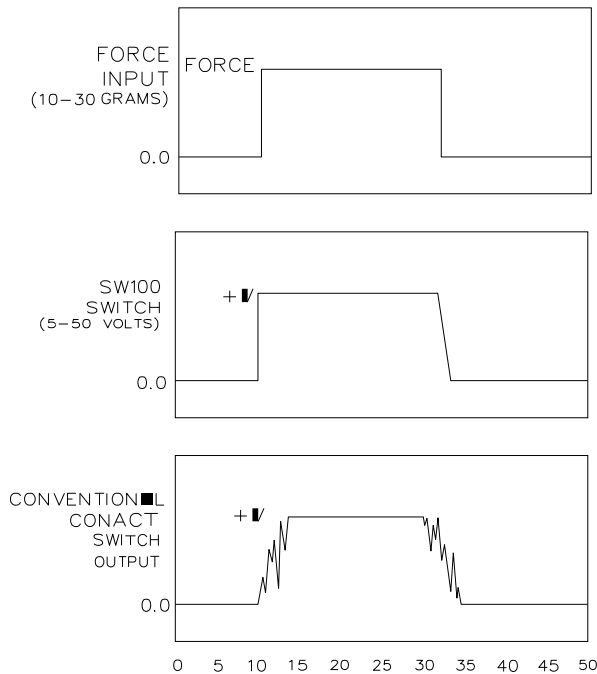

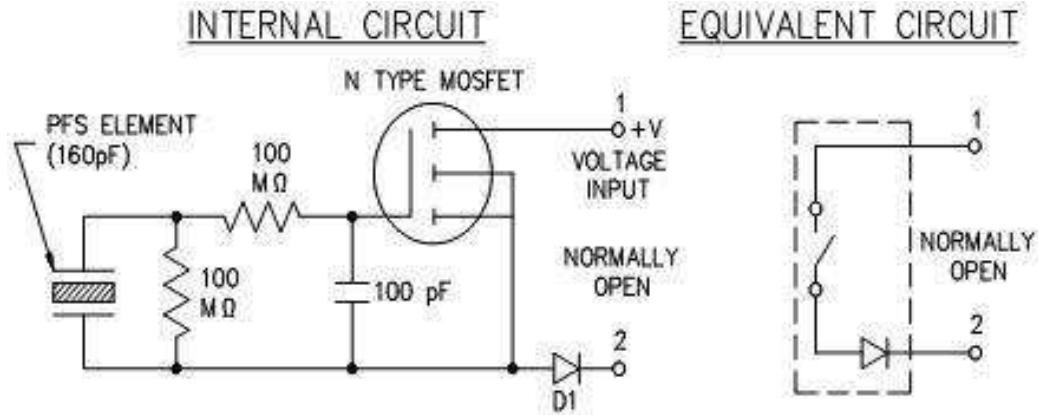

**SW100 BEAM CALIBRATION EXPERIMENT**

To investigate the open-circuit output voltage developed by the beam element from an SW100-02 (curved beam) switch, all circuit components were removed from the PCB and the device mounted such that the beam tip was resting under slight spring force against a baseplate.

Shim elements of known thickness were withdrawn from underneath the beam tip at various speeds, such that the beam experienced a “step” deflection.

The piezo film element (capacitance nominally 160 pF) was connected to a 4.7 nF load capacitance. The voltage across the combined capacitance (4.86 nF) was observed using a “x100” probe (100 megohm impedance). The resulting electrical time constant was thus 0.486 seconds, meaning that results were almost independent of speed of actuation. The measured peak voltage for various step heights was measured, and scaled to give charge output. This charge output was then used to calculate open-circuit output voltage (by dividing the charge obtained by the source capacitance of 160 pF).

**RESULTS**

The open-circuit output voltage was found to follow a logarithmic law with step height, of the form:  $\text{Log}_{10}(V) = m \cdot \text{log}_{10}(h) + c$  where  $m = 0.865$ ,  $c = 1.556$ ,  $V$  is in volts, and  $h$  in mm. A plot of these results follows:

Step (mm)	Charge (nC)	O/C Volts	Best Fit (V)
0.00			0.1
0.33	2.2	13.3	13.9
0.66	4.2	26.0	25.2
1.00	5.9	36.5	35.8
1.33	7.4	45.5	46.0
1.66	9.0	55.5	55.8
1.99	11.1	68.4	65.3
2.32	12.5	77.4	74.6
2.65	13.8	85.3	83.7
3.00	14.8	91.1	92.7
3.32	16.1	99.6	101.5
3.65	16.9	104.5	110.3

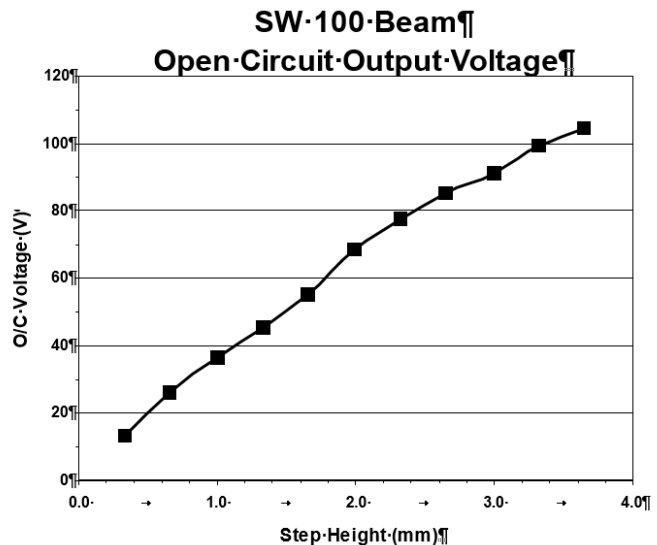

**TYPICAL INTERFACE**

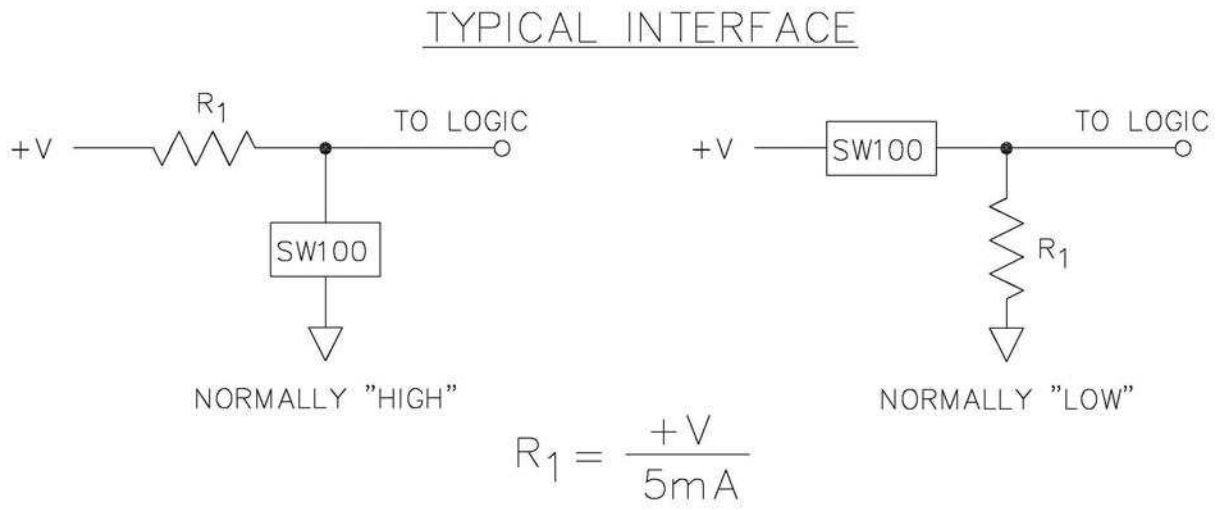

**ORDERING INFORMATION**

Description	Beam Tip	Stroke Direction to Trigger Switch	Part Number
SW100-01-R	Flat	Reversed	1002393-1
SW100-01-F	Flat	Forward	1002393-2
SW100-02-R	Curved	Reversed	1002132-1
SW100-02-F	Curved	Forward	1002132-2

**NORTH AMERICA**

Measurement Specialties, Inc.,  
 a TE Connectivity Company  
 Tel: +1-800-522-6752  
 Email: [customercare.dtm@te.com](mailto:customercare.dtm@te.com)

**EUROPE**

MEAS Deutschland GmbH  
 a TE Connectivity Company  
 Tel: +49-800-440-5100  
 Email: [customercare.dtm@te.com](mailto:customercare.dtm@te.com)

**ASIA**

Measurement Specialties (China), Ltd.,  
 a TE Connectivity Company  
 Tel: +86 0400-820-6015  
 Email: [customercare.chdu@te.com](mailto:customercare.chdu@te.com)

**TE.com/sensorsolutions**

Measurement Specialties, Inc., a TE Connectivity company.

Measurement Specialties, TE Connectivity, TE Connectivity (logo) and EVERY CONNECTION COUNTS are trademarks. All other logos, products and/or company names referred to herein might be trademarks of their respective owners.

The information given herein, including drawings, illustrations and schematics which are intended for illustration purposes only, is believed to be reliable. However, TE Connectivity makes no warranties as to its accuracy or completeness and disclaims any liability in connection with its use. TE Connectivity's obligations shall only be as set forth in TE Connectivity's Standard Terms and Conditions of Sale for this product and in no case will TE Connectivity be liable for any incidental, indirect or consequential damages arising out of the sale, resale, use or misuse of the product. Users of TE Connectivity products should make their own evaluation to determine the suitability of each such product for the specific application.

© 2015 TE Connectivity Ltd. family of companies All Rights Reserved.