

# OPERATION MANUAL MODEL 832 & 832M1 ACCELEROMETER

---



### WARRANTY

TE Connectivity accelerometers are warranted during a period of one year from date of shipment to original purchaser to be free from defects in material and workmanship. The liability of Seller under this warranty is limited to replacing or repairing any instrument or component thereof which is returned by Buyer, at his expense, during such period and which has not been subjected to misuse, neglect, improper installation, repair, alteration, or accident. Seller shall have the right to final determination as to the existence and cause of a defect. In no event shall Seller be liable for collateral or consequential damages. This warrant is in lieu of any other warranty, expressed, implied, or statutory; and no agreement extending or modifying it will be binding upon Seller unless in writing and signed by a duly authorized officer.

### RECEIVING INSPECTION

Every TE Connectivity accelerometer is carefully inspected and is in perfect working condition at the time of shipment. Each accelerometer should be checked as soon as it is received. If the unit is damaged in any way, or fails to operate, a claim should immediately be filed with the transportation company.

### SERVICE CONCERNS

If a TE Connectivity instrument requires service, first contact the nearest TE Connectivity representative. They may be able to solve the problem without returning the unit to the factory. If it is determined that factory service is required, call Customer Service at the regional headquarters for an RMA number before return.

### RETURNS

All units being returned to the factory require an RMA (Return Material Authorization) number before they will be accepted. This number may be obtained by calling Customer Service at the regional headquarters with the following information; model number(s), quantity, serial number(s), and symptoms of the problem, if being returned for service. You must include the original purchase order number if under warranty.

### RECALIBRATION SERVICES

The Vibration Sensors Design Center and its two manufacturing facilities in China and France offer factory re-calibration services for Piezoresistive, Piezoelectric and Integrated Electronics Piezoelectric (IEPE, ISOTRON, ICP, etc.) accelerometers. NIST (US), DKD (Germany), COFRAC (France) traceable calibration services on sensitivity at 100 Hz (102 or 120 Hz in Europe) and full frequency sweeps are offered. Contact the regional headquarters for pricing information.

# MODEL 832 & 832M1 ACCELEROMETER

## DESCRIPTION

The Model 832 & 832M1 are low power triaxial accelerometers designed to be mounted on circuit boards. The accelerometers are ideal for embedded applications and is packaged in a hermetic ceramic LCC package. The Model 832 & 832M1 feature stable piezo-ceramic crystals with full power and signal conditioning that draw a maximum current of 4 micro-Amps (22 micro-Amps for 832M1). The accelerometers are offered in ranges from  $\pm 100g$  to  $\pm 500g$  with a flat response up to greater than 2000Hz (greater than 6000Hz for 832M1).

## INSTALLATION

The model 832 & 832M1 accelerometers are designed to be soldered to printed circuit boards or hybrid substrates. It is critical that the substrate has a low coefficient of expansion and that you have good mechanical coupling between the sensor and the mounting surface to ensure good transmissibility. Ceramic circuit boards are recommended but FR4 boards can also be used with a recommended thickness of 0.062" (1.57mm). The model 832 accelerometer is not to be reflow soldered in an oven since the reflow temperatures may shift the output sensitivity. It is recommended to reflow solder on a hot plate or manually solder the accelerometer to the circuit boards. The following guidelines should be followed.

- The recommended dimensions for the mounting pads on the circuit board are detailed below.
- Pre-tinning of the accelerometer pads is recommended to prevent gold embrittlement.
- Use a suitable RMA flux coated solder paste.
- A recommended stencil thickness is .008" (0.2mm).
- If using a hot plate, do not heat above +250°C and leave only on plate long enough for solder to reflow.

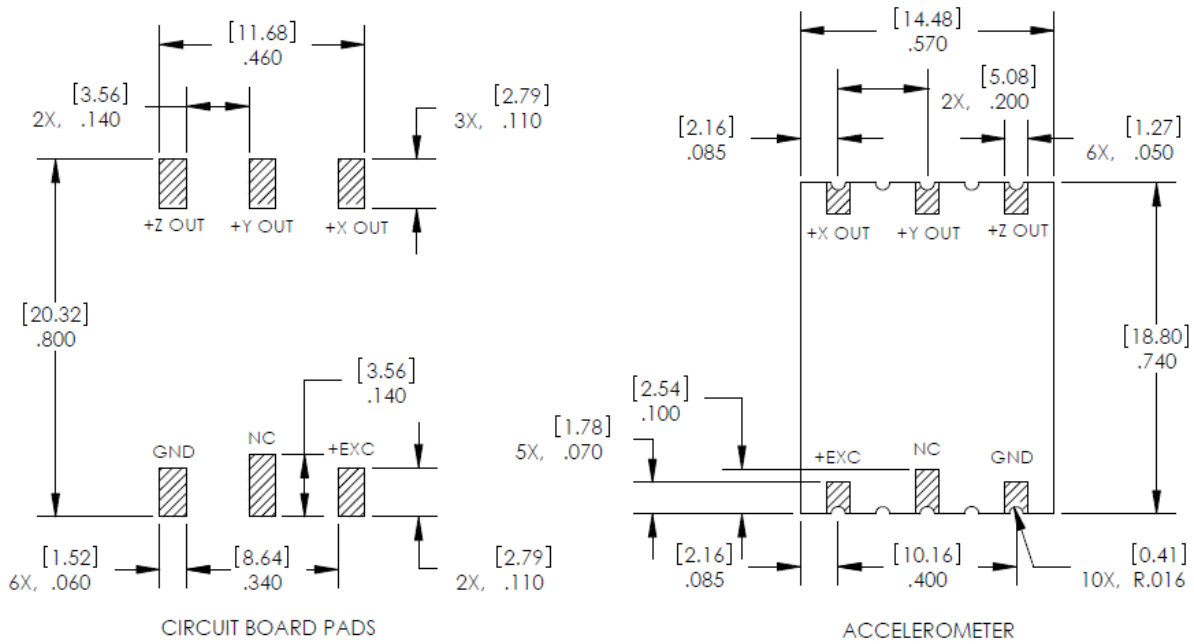

If the accelerometers are to be subjected to high amplitude shocks during operation then it is also recommended to apply a thin layer of epoxy underneath the accelerometers after solder attachment. A low viscosity cyanoacrylate with a room temperature cure such as Loctite 4501 is recommended.

## MODEL 832 & 832M1 ACCELEROMETER

### EXCITATION

Although the model 832 & 832M1 are designed to be operated by 3.3Vdc battery power for optimum performance, the accelerometer can also be powered by excitation voltages (ExcV) ranging from 2.7 to 5.5Vdc. However, excitation voltages other than 3.3Vdc will affect the full scale range of the accelerometer since the bias voltage is a function of excitation voltage.

The following formula can be used to calculate the full scale range of the accelerometer when using different excitation voltages other than 3.3Vdc.

$$\text{Full scale range (g)} = [\text{ExcV} - 0.3\text{V} - (\text{ExcV} / 2)] / \text{Sensitivity (V/g)}$$

Example; a model 832-0200 with z-axis sensitivity of 6.41mV/g and 2.8Vdc excitation

$$\text{Full scale range} = [2.8\text{V} - 0.3\text{V} - (2.8\text{V} / 2)] / .00641\text{V/g} = 172\text{g}$$

### TEMPERATURE COMPENSATION

The model 832 & 832M1 accelerometers incorporate piezo-ceramic crystals in shear mode that have a stable temperature performance over the operating range of the accelerometers. Additional temperature compensation can be accomplished by using an external ASIC with onboard temperature sensing to further correct temperature induced errors.

### NOISE FLOOR SPECIFICATIONS

The model 832 & 832M1 broadband and spectral noise floor specifications are detailed in table below.

		-0025	-0050	-0100	-0200	-0500
Broadband Noise (uV, 0.1Hz ~ 10kHz)	832	300	210	160	150	160
	832M1	110	90	50	40	50
832 Spectral Noise (* $\sqrt{\text{Hz}}$ )	@10Hz	120ug	120ug	120ug	120ug	400ug
	@100Hz	80ug	80ug	80ug	80ug	320ug
	@1000Hz	40ug	40ug	40ug	40ug	160ug
832M1 Spectral Noise (* $\sqrt{\text{Hz}}$ )	@10Hz	120ug	160ug	160ug	160ug	600ug
	@100Hz	40ug	40ug	40ug	40ug	160ug
	@1000Hz	20ug	16ug	16ug	16ug	80ug

## FREQUENTLY ASKED QUESTIONS

**Question:** The datasheet shows the operating temperature from -40°C to +125°C. -40°C is not low enough; we need beyond -55°C. What is your plan of meeting this requirement?

**Response:** We tested the bias at -55°C. Test result of 832-0500 DC bias change with temperature is shown below, DC Bias changes about 0.5% at -55°C compared to 25°C:

	25°C	-55°C
X	1.7423 V	1.7535 V
Y	1.7412 V	1.7477 V
Z	1.7928 V	1.8035 V

Total current supply is 4.1uA at -55°C which is still within specification. Model 832M1 has no problem working down at -55°C

**Question:** Do you happen to have any more detail for the assembling of this part to a board? Our board assembly department is a little concerned about manually soldering this part. It says on your data sheet that the accelerometer can't go through solder reflow at high temperature and that manual soldering is recommended. I was hoping for some more clarification on this statement.

**Response:** The reason for the caution is the potential risk of sensitivity shift in the output after reflow soldering. The units will survive the reflow soldering process. We caution against this process since we have seen a 1-2% sensitivity drop after reflow soldering. For our reflow profile we have a peak temperature of +250°C since we use non-leaded solder for RoHS compliance. A lower reflow profile may result in negligible sensitivity shift. If you can use leaded solder such Sn63 or Sn62 (183°C and 179°C eutectic respectively) then the peak reflow temp should not have to exceed +210°C (60sec max). This should then allow reflow soldering.

**Question:** We generally conformal coat our circuit boards to protect the circuitry, would there be any concern with conformal coating?

**Response:** No concerns with conformal coating. The seismic mass system and electronics are all hermetically sealed under the cover.

**Question:** Can we bake the board after coating?

**Response:** Yes. There will be no problem with an over-night bake at +200°F on the model 832M1. We bake the units for 24hours at +250°F during manufacture.

**Question:** Just a clarification, at 0g output, is the accelerometer output Supply Voltage/2? So that when we have a negative acceleration we approach 0 but not negative?

**Response:** Yes, you are correct. The output will swing nominally +/-1.25V about the bias voltage. For a +/-100g range accelerometer with 3.3V excitation (bias at 1.65V), the output would be nominally be 0.4V to 2.9V.

**Question:** You mentioned about getting us an equation to calculate the measurement range based on our bias voltage. We talked about how the lower bias voltage would lower the maximum measurement of this accelerometer and I was hoping to get a better understanding of this.

**Response:** Page 5 in this manual, under the 'Excitation' paragraph, discusses how to calculate the full-scale range of the accelerometer based on excitation voltages other than the nominal 3.3V. Let us know if you need further information. Our engineers have confirmed that the minimum excitation voltage is in fact 2.7V. We specified 3.3V in our datasheet to give us some margin. We also confirmed that we had previously performed a signal warm-up test on our model 832M1. The signal converged to 98% of its final value at 30msec. There was no overshoot. It was typical of a single-pole response characteristic that was determined by its filtering ...95% (lapse of three time constants).

**Question:** Can Measurement Specialties provide a higher temp version of Model 834M1?

**Response:** Yes, we can make high temp version which operates from -40°C to +150°C, but the current consumption will be 60uA.

**Question:** If I use structural epoxy around the perimeter to reinforce the vibration sensor onto the circuit card (after soldering) will this affect the vibration response of the sensor? Is there a reinforcement technique you would recommend?

**Response:** No, this will not affect the response of the sensor and in fact it is recommended to reinforce the sensor attachment after soldering. Typically we recommend the customer use a low viscosity cyanoacrylate adhesive and allow the epoxy to wick underneath the circuit board.

**Question:** What mounting techniques and materials are recommended to achieve the best high frequency response?

**Response:** To achieve the best frequency response, we recommend mounting the accelerometer directly to the structure to be measured. An adhesive can be used to secure the accelerometer. Take precautions not to short the output pads underneath the circuit board. Good frequency response can also be achieved by mounting the accelerometer onto a ceramic or hybrid circuit board. FR4 boards should be avoided for applications requiring wide bandwidth measurements since the FR4 material can impart a resonance to your measuring system. If attaching wires to the output pads then these need to be properly secured/anchored at regular intervals to minimize cable motion that can add noise and resonances to the output signal.

**Question:** What is the material composition of the plating on the solder pads?

**Response:** The circuit board traces are Titanium-Tungsten plated with Nickel and Gold. 50micro-inches min of Au (99.9% pure gold per MIL-G-45204, Type III, grade A) over 50-350micro-inches of Ni (per AMS-QQ-N-290, Class I

### NORTH AMERICA

Measurement Specialties, Inc.,  
a TE Connectivity Company  
1000 Lucas Way  
Hampton, VA 23666  
United States  
Tel: +1 757 766 1500  
Email: [customercare.hmpt@te.com](mailto:customercare.hmpt@te.com)

Measurement Specialties, Inc.,  
a TE Connectivity Company  
Vibration Sensors Design Center  
32 Journey, Suite 150  
Aliso Viejo, CA 92656, USA  
Tel: +1 949 716 7324

### [te.com/sensorsolutions](http://te.com/sensorsolutions)

Measurement Specialties, Inc., a TE Connectivity company.

Measurement Specialties (MEAS), American Sensor Technologies (AST), TE Connectivity, TE Connectivity (logo) and EVERY CONNECTION COUNTS are trademarks. All other logos, products and/or company names referred to herein might be trademarks of their respective owners.

The information given herein, including drawings, illustrations and schematics which are intended for illustration purposes only, is believed to be reliable. However, TE Connectivity makes no warranties as to its accuracy or completeness and disclaims any liability in connection with its use. TE Connectivity's obligations shall only be as set forth in TE Connectivity's Standard Terms and Conditions of Sale for this product and in no case will TE Connectivity be liable for any incidental, indirect or consequential damages arising out of the sale, resale, use or misuse of the product. Users of TE Connectivity products should make their own evaluation to determine the suitability of each such product for the specific application.

© 2016 TE Connectivity Ltd. family of companies All Rights Reserved.

### EUROPE

MEAS Deutschland GmbH  
a TE Connectivity Company  
105 av. du Général Eisenhower  
BP 1036, 31023 Toulouse Cedex, France  
Tel: +33 (0) 561 194 543  
Email: [customercare.tlse@te.com](mailto:customercare.tlse@te.com)

### ASIA

Measurement Specialties China Ltd.,  
a TE Connectivity Company  
F1.6-4D, Tian An Development Compound  
Shenzhen, China 518057  
Tel: +86 755 8330 1004  
Phone: +86-755-33305088  
Email: [customercare.shzn@te.com](mailto:customercare.shzn@te.com)

Rev B