

# **OPERATION MANUAL MODEL 4332M3 ACCELEROMETER**

---



## MODEL 4332M3 ACCELEROMETER

---

### WARRANTY

Measurement Specialties, Inc. accelerometers are warranted during a period of one year from date of shipment to original purchaser to be free from defects in material and workmanship. The liability of Seller under this warranty is limited to replacing or repairing any instrument or component thereof which is returned by Buyer, at his expense, during such period and which has not been subjected to misuse, neglect, improper installation, repair, alteration, or accident. Seller shall have the right to final determination as to the existence and cause of a defect. In no event shall Seller be liable for collateral or consequential damages. This warrant is in lieu of any other warranty, expressed, implied, or statutory; and no agreement extending or modifying it will be binding upon Seller unless in writing and signed by a duly authorized officer.

### RECEIVING INSPECTION

Every Measurement Specialties, Inc. accelerometer is carefully inspected and is in perfect working condition at the time of shipment. Each accelerometer should be checked as soon as it is received. If the unit is damaged in any way, or fails to operate, a claim should immediately be filed with the transportation company.

### SERVICE CONCERNS

If a Measurement Specialties, Inc. instrument requires service, first contact the nearest Measurement Specialties, Inc. representative. They may be able to solve the problem without returning the unit to the factory. If it is determined that factory service is required, call Customer Service at the regional headquarters for an RMA number before return.

### RETURNS

All units being returned to the factory require an RMA (Return Material Authorization) number before they will be accepted. This number may be obtained by calling Customer Service at the regional headquarters with the following information; model number(s), quantity, serial number(s), and symptoms of the problem, if being returned for service. You must include the original purchase order number if under warranty.

### RECALIBRATION SERVICES

The Vibration Sensors Design Center and its two manufacturing facilities in China and France offer factory re-calibration services for Piezoresistive, Piezoelectric and Integrated Electronics Piezoelectric (IEPE, ISOTRON, ICP, etc.) accelerometers. NIST (US), DKD (Germany), COFRAC (France) traceable calibration services on sensitivity at 100 Hz (102 or 120 Hz in Europe) and full frequency sweeps are offered. Contact the regional headquarters for pricing information.

## MODEL 4332M3 ACCELEROMETER

### DESCRIPTION

The Model 4332M3 is a low noise, 4-20mA output triaxial accelerometer packaged in a rugged stainless steel housing with an integral cable assembly. The Model 4332M3 is offered in ranges from  $\pm 2$  to  $\pm 20g$  and features gas damped MEMS sensing elements. The accelerometer features a bandwidth up to 300Hz and an operating temperature range of  $-40^{\circ}\text{C}$  to  $+85^{\circ}\text{C}$ . The accelerometer is also certified to IP68 protection up to 40m depth.

### INSTALLATION

The model 4332M3 accelerometer is designed to be screw mounted but can also be adhesively mounted if the installation does not allow for screw mounting.

#### Screw Mounting

For screw mounting of accelerometers the following guidelines should be followed:

- The mounting surface should be clean and free of any residue or foreign material.
- The mounting surface should be smooth, flat, and with a maximum surface roughness of 32 micro-inches rms.
- Optional: Apply a light coating of coupling fluid (machine oil or silicone grease) on the mating surface to maximize the usable frequency range.
- Torque screws to recommended limits using steel washers under the heads of the mounting screws. Use manual torque wrench (do not use electric tools).

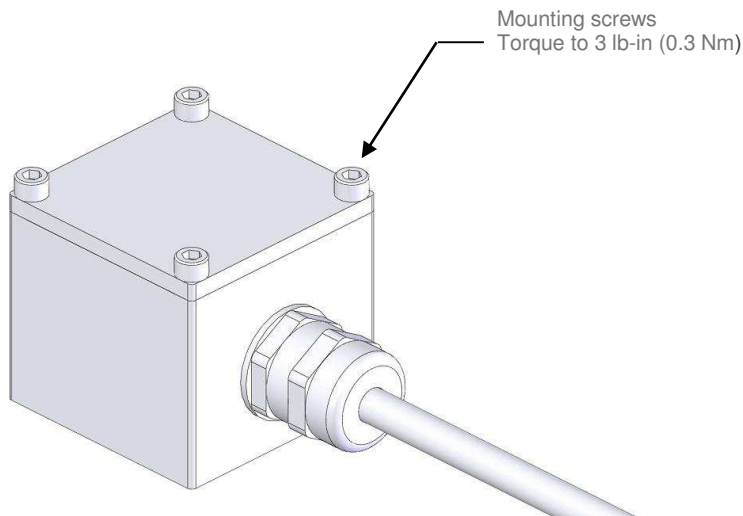

#### Adhesive Mounting

To avoid damaging the accelerometer during subsequent removal, it is recommended to use an adhesive mounting adaptor for this method of attachment. TE offers the AC-A05172 adhesive mounting adaptor for purchase. For adhesively mounting of accelerometers the following guidelines should be followed:

- The mounting surface should be clean and free of any residue or foreign material.
- The mounting surface should be smooth, flat, and with a maximum surface roughness of 64 micro-inches rms.
- For best high frequency performance a cyanoacrylate adhesive is recommend. A thin layer offers best frequency response.
- Soften adhesive cured adhesive with a chemical debonder (eg. acetone) prior to removal. Gently shear accelerometer loose from the mounting surface after waiting a few minutes for the debonding agent to penetrate the epoxy. Make sure not to use excessive force as this may damage the accelerometer.

# MODEL 4332M3 ACCELEROMETER

## CABLE ROUTING

The model 4332M3 accelerometer incorporates a PVC jacketed cable with an integral shield. The cable assembly should be properly secured at regular intervals during testing. It is recommended to use clamps, wax, or tape to secure the cable to minimize cable motion that can add noise to the output signal. The initial attachment should be within two to three inches of the accelerometer.

Avoid routing cables near high-voltage wires and also ground the shield at the signal conditioner to minimize ground loops.

## 4-20mA SIGNAL OUTPUT

The accelerometer is designed to be operated from 7-24Vdc excitation and provides a 4.0 to 20mA full scale output. The output is DC-coupled and should be used in single-ended mode (3-wire). The electrical hookup for operation is detailed below.

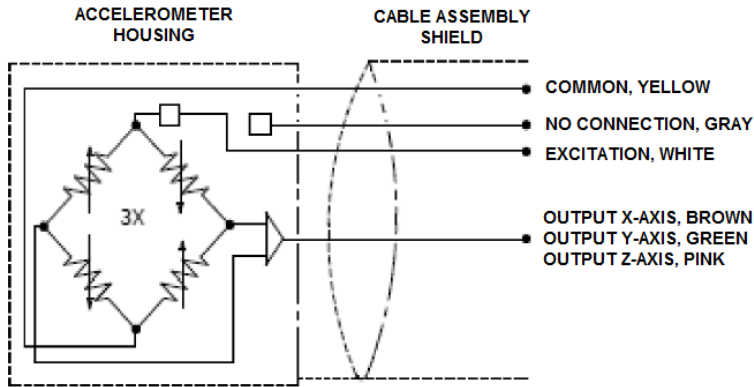

. A typical system installation for 4332M3 accelerometer.

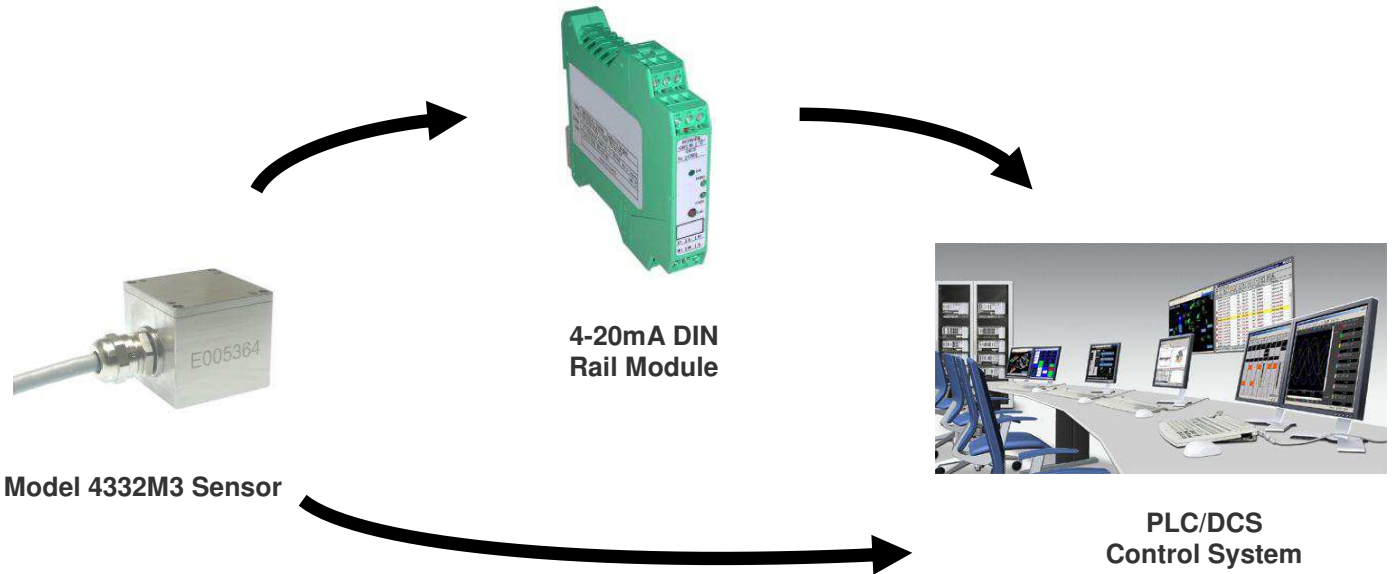

# MODEL 4332M3 ACCELEROMETER

## NOISE FLOOR SPECIFICATIONS

The model 4332M3 accelerometer incorporates a LP filtered output for a high output signal. The noise specifications for this accelerometer are detailed in table below.

FULL SCALE RATING (g-pk)	SENSITIVITY (mV/g)	±5% AMPL PASSBAND (Hz)	PASSBAND NOISE (µg-rms)	SPECTRAL NOISE (µg-rms/√Hz)	DYNAMIC RANGE (dB)
2	1000	200	25	2	98
5	400	300	50	3	100
10	200	300	100	7	99
20	100	300	200	18	96

## FREQUENCY RESPONSE CURVES

The typical frequency response curves for the model 4332M3 accelerometer are illustrated below.

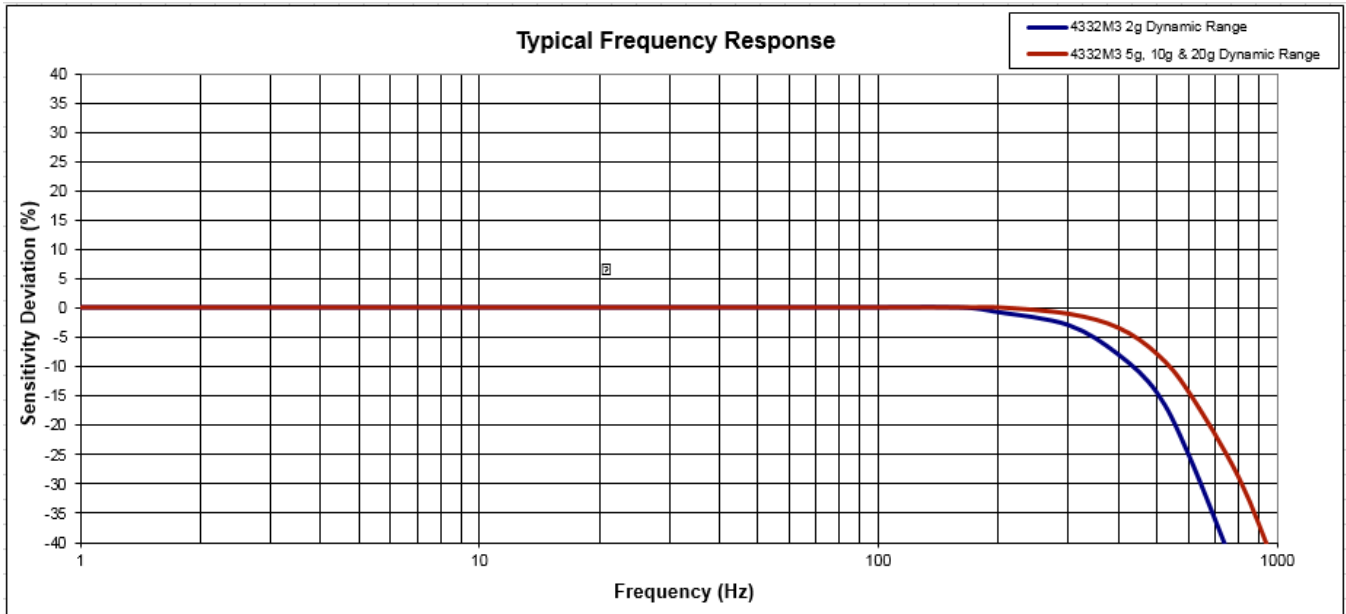

## MODEL 4332M3 ACCELEROMETER

---

### NORTH AMERICA

Measurement Specialties, Inc.,  
a TE Connectivity Company  
1000 Lucas Way  
Hampton, VA 23666  
United States  
Tel: +1 757 766 1500  
Email: [customer-care.hmpt@te.com](mailto:customer-care.hmpt@te.com)

Measurement Specialties, Inc.,  
a TE Connectivity Company  
Vibration Sensors Design Center  
32 Journey, Suite 150  
Aliso Viejo, CA 92656, USA  
Tel: +1 949 716 7324

### EUROPE

MEAS Deutschland GmbH  
a TE Connectivity Company  
Impasse Jeanne BENOZZI  
CS 83 163, 31027 Toulouse Cedex 3, France  
Tel: +33 (0) 582 08 22 00  
Email: [customer-care.tlse@te.com](mailto:customer-care.tlse@te.com)

### ASIA

Measurement Specialties China Ltd.,  
a TE Connectivity Company  
No. 26, Langshan Road  
Shenzhen High-tech Park (North)  
Nanshan District, Shenzhen 518057  
China  
Phone: +86-755-3330-5088  
Email: [customer-care.shzn@te.com](mailto:customer-care.shzn@te.com)

### [te.com/sensorsolutions](http://te.com/sensorsolutions)

Measurement Specialties, Inc., a TE Connectivity company.

Measurement Specialties (MEAS), American Sensor Technologies (AST), TE Connectivity, TE Connectivity (logo) and EVERY CONNECTION COUNTS are trademarks. All other logos, products and/or company names referred to herein might be trademarks of their respective owners.

The information given herein, including drawings, illustrations and schematics which are intended for illustration purposes only, is believed to be reliable. However, TE Connectivity makes no warranties as to its accuracy or completeness and disclaims any liability in connection with its use. TE Connectivity's obligations shall only be as set forth in TE Connectivity's Standard Terms and Conditions of Sale for this product and in no case will TE Connectivity be liable for any incidental, indirect or consequential damages arising out of the sale, resale, use or misuse of the product. Users of TE Connectivity products should make their own evaluation to determine the suitability of each such product for the specific application.

© 2016 TE Connectivity Ltd. family of companies All Rights Reserved.

