

LOC	DIST	REVISIONS			
		REV.	DATE	BY	APPV
A1	-	A2	29NOV2012	MDA	HHC
		A3	17DEC2012	MDA	HHC

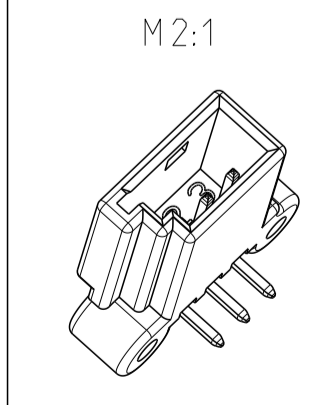
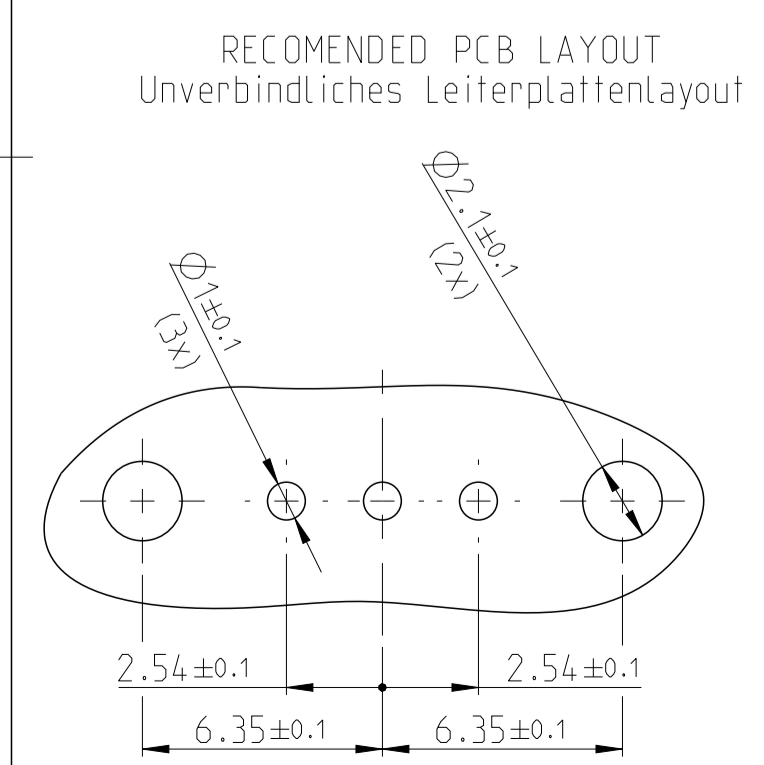
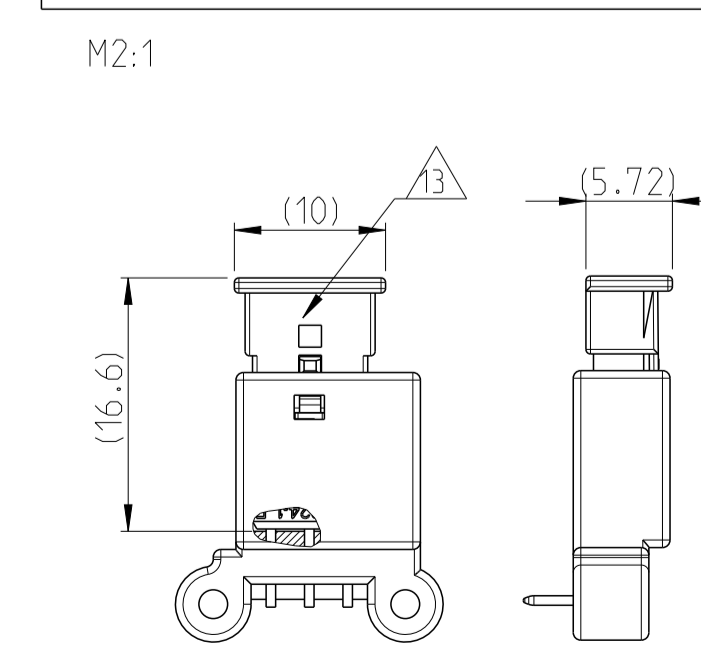
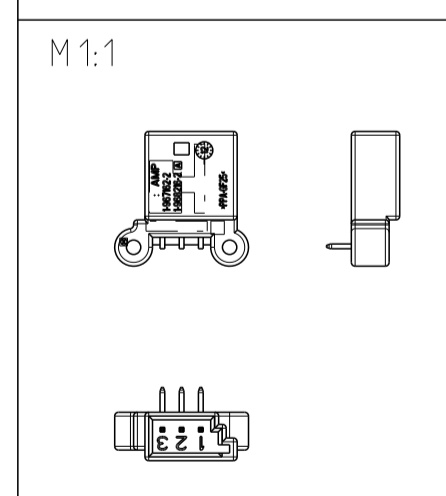
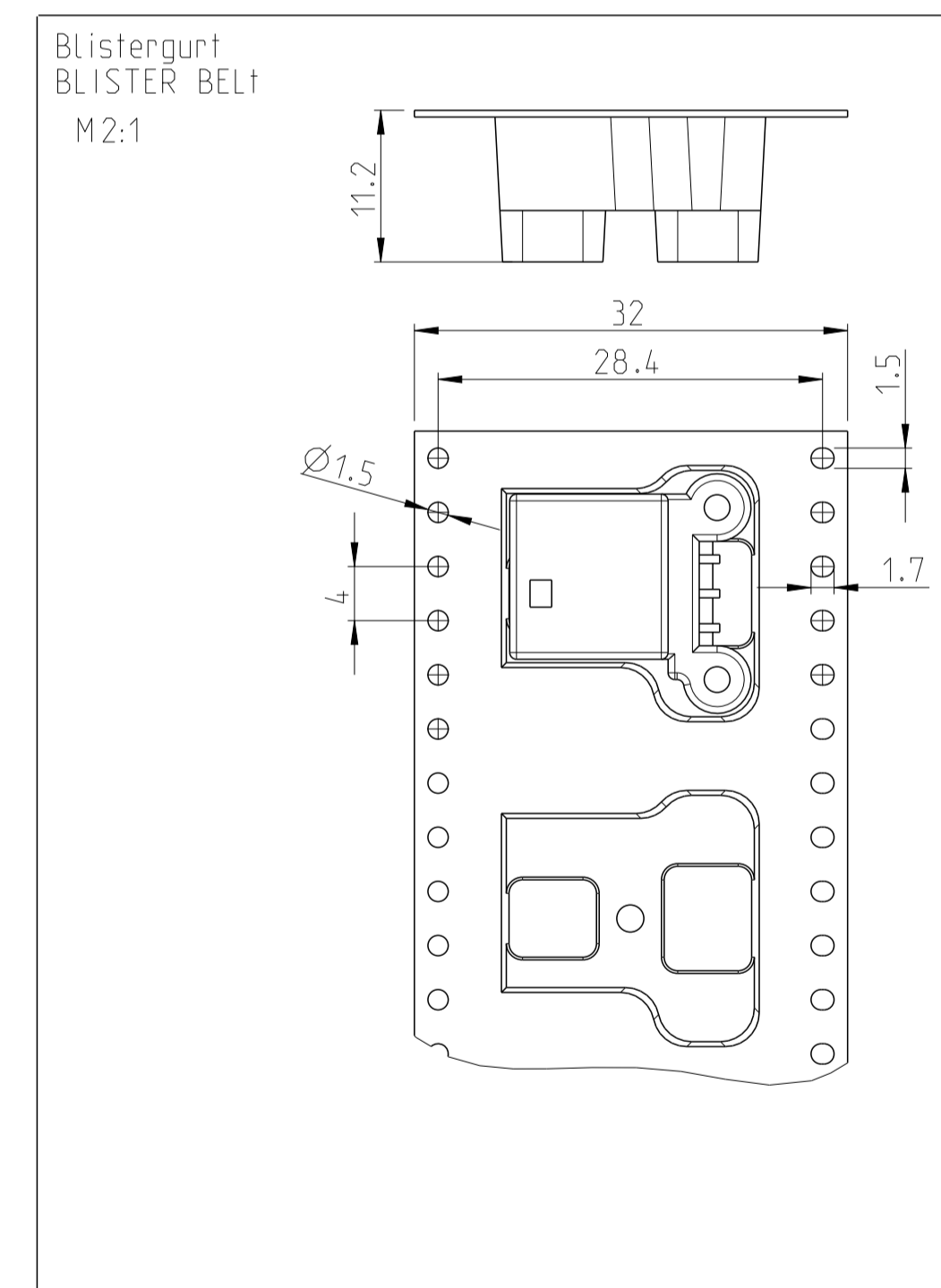
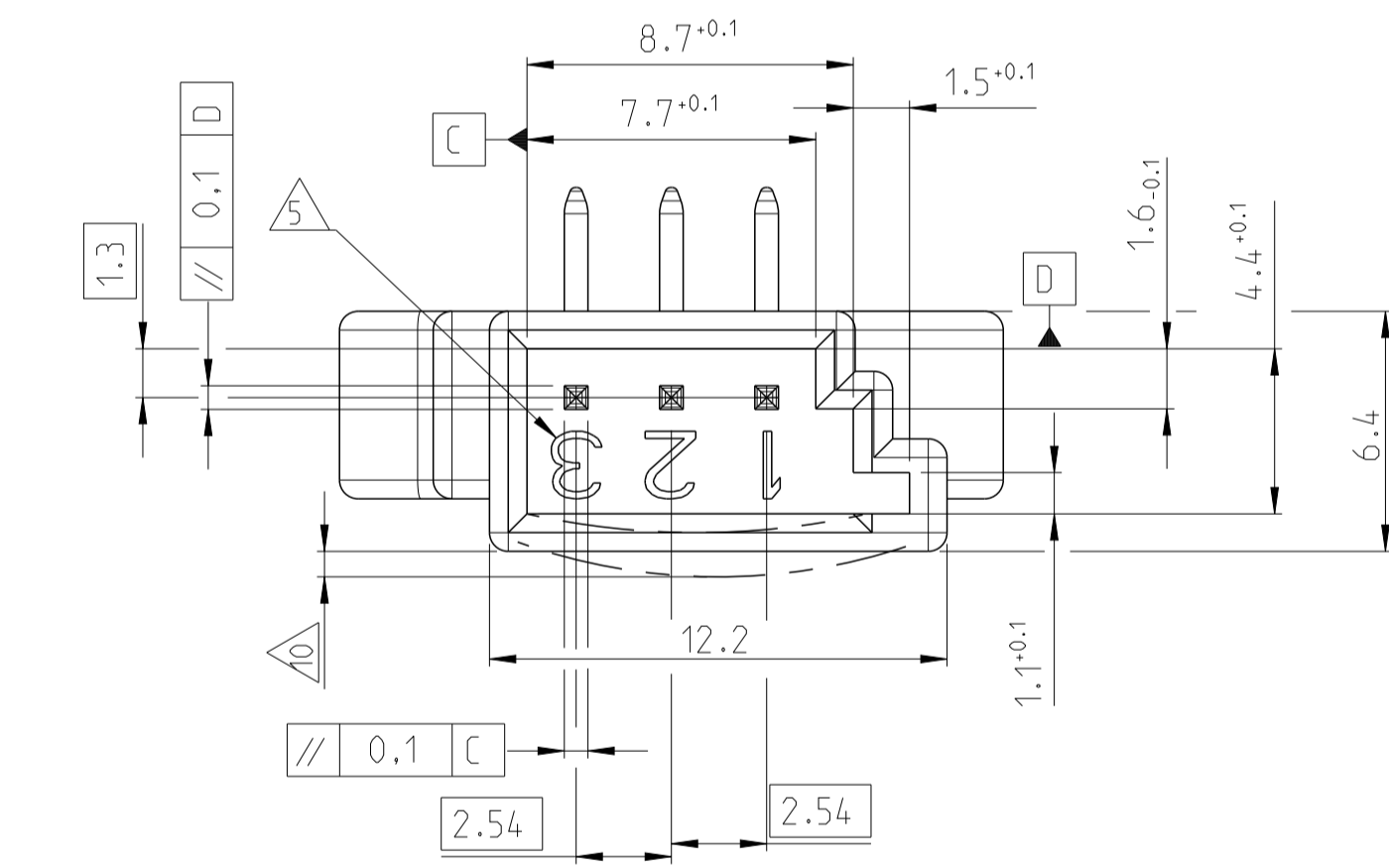
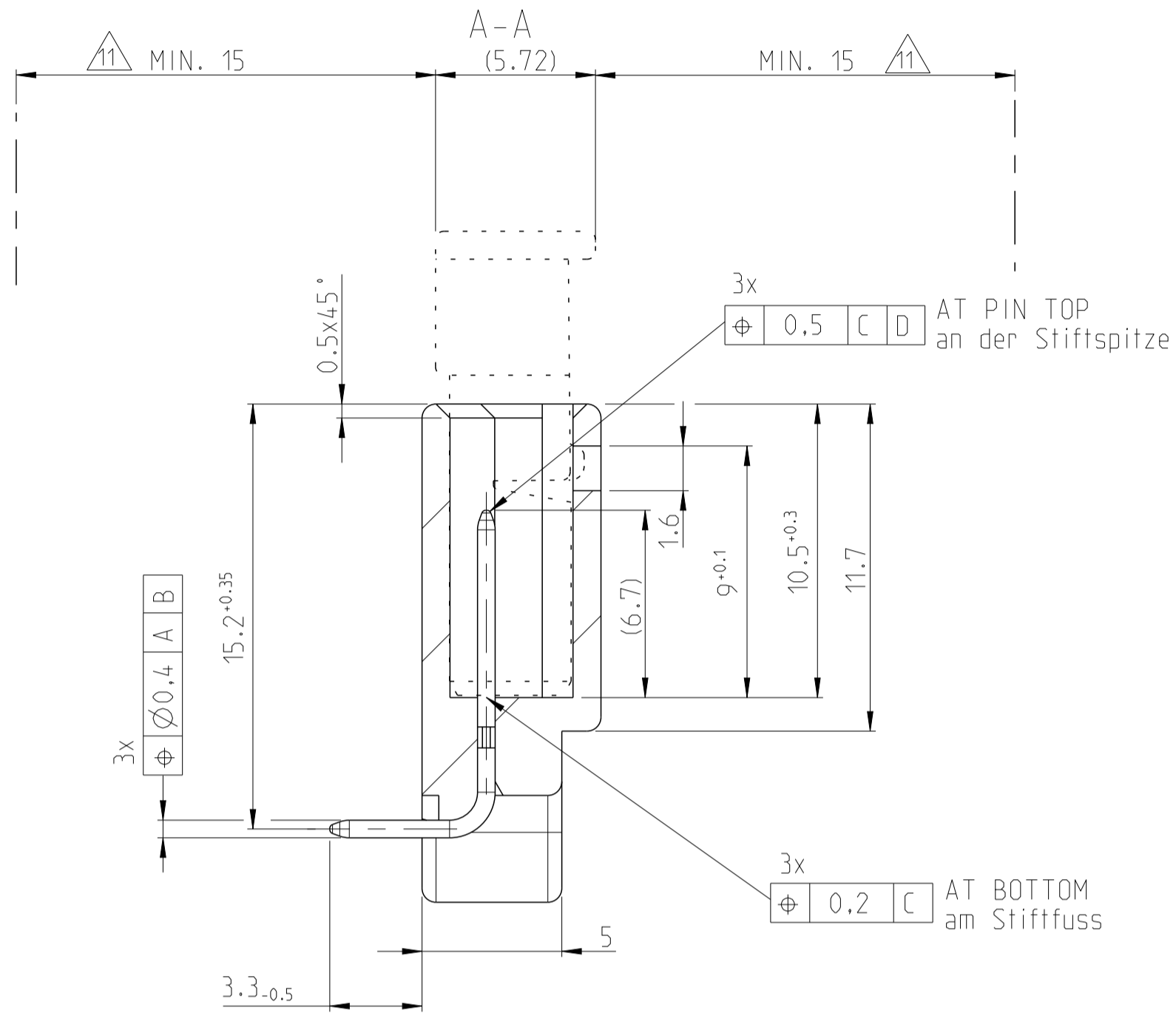
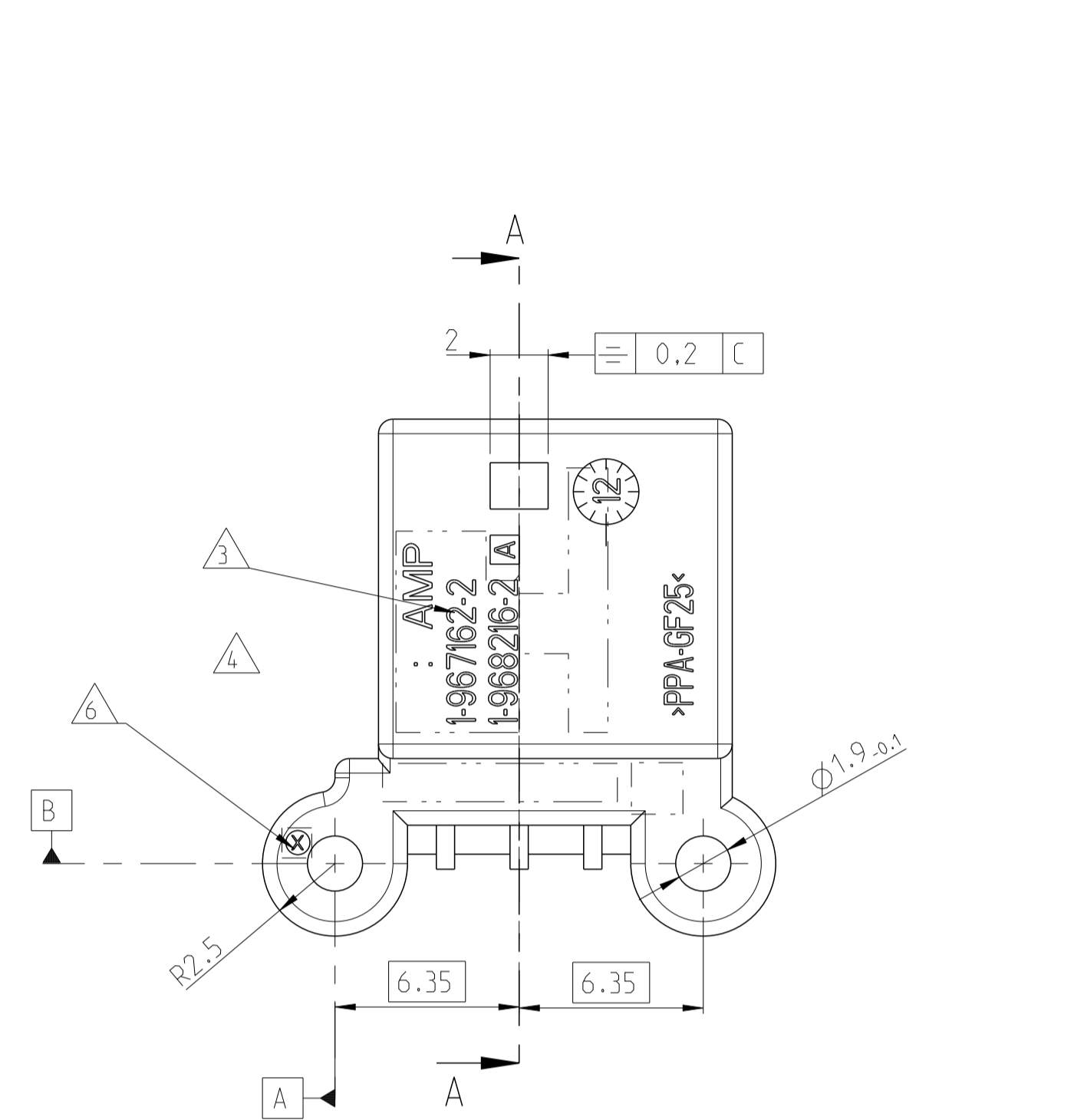

- NOTES
Bemerkungen
- ONLY THE GERMAN LANGUAGE VERSION IS AUTHORITATIVE
Massgebend ist nur der deutsche Text
 - CODING A AS SHOWN
Kodierung A wie gezeichnet
 - SUPPLIER-MARK
Lieferantenkennzeichnung
 - MATERIAL MARKING
Materialkennzeichnung
 - CAVITY IDENTIFICATION
Kammer-Kennzeichnung
 - MOULD CAVITY MARKING
Formnest-Kennzeichnung
 - SUPPLIED FORM: LAYERS IN CARDBOARD BOX
Auslieferungsform: Lagenweise im Karton
 - SUPPLIED FORM: BLISTER BELT, COVERING TAPE AND REEL ACC. TO DIN/IEC 286 PART 3
Auslieferungsform: Blistergurt, Abdeckband und Spule nach DIN/IEC 286 Teil 3
 - REFLOW TYPE
Reflow Variante
 - IN THIS AREA MIN. 0.5mm SPACE FOR MOVEMENT OF THE HOUSING
Gehäuse muss in diesem Bereich mindestens 0.5mm nach aussen federn können
 - SPACE FOR ACTIVITY
Betaetigungsfreiraum
- 1- -1 AS SHOWN
1- -1 wie gezeigt

NOTE Bem.	FEATURE Merkmal	Tyco Electronics - No.
12	INTERFACE DRAWING Ausfuehrungsvorschrift	114-18063-018
13	USEABLE MATING PART BY TYCO ELECTRONICS Passendes Gegenstueck von Tyco Electronics	1241324

Verpackung PACKING	Benennung TITLE	Masse [kg] MASS [kg]	COD	Tyco Electronics Bestell-Nr. ORDER-NO.	REV	QTY	Benennung TITLE	Werkstoff MATERIAL	Oberflaeche/Farbe SURFACE/COLOUR	Pos. ITEM
	Steckerleiste	0.001	A	1-967162-3	A	3	0.63 Stift/PIN	Cu Fe 2	verzinkt TIN PLATED	2
	Steckerleiste	0.001	A	1-967162-2	A	1	Stiftwanne MQS PIN HOUSING	PPA-GF25 Ultradid TKR435G5/BASF	schwarz BLACK	1
						1	0.63 Stift/PIN	Cu Fe 2	verzinkt TIN PLATED	2
						1	Stiftwanne MQS PIN HOUSING	PPA-GF25 Ultradid TKR435G5/BASF	schwarz BLACK	1

THIS DRAWING IS UNPUBLISHED. RELEASED FOR PUBLICATION. DATE: 2009. MATED WITH: 355894 22.
 DIESER ZEICHNUNGSDRUCK IST NUR FÜR DEN GEBRAUCH BEI DER BESTELLENDE UNTERSCHREIBUNG.
 THIS DRAWING IS UNPUBLISHED. RELEASED FOR PUBLICATION. DATE: 2009. MATED WITH: 355894 22.
 DIESER ZEICHNUNGSDRUCK IST NUR FÜR DEN GEBRAUCH BEI DER BESTELLENDE UNTERSCHREIBUNG.

OWN	P. Henzel	26SEPT1996	TE Connectivity
CHK	J. Byll	30SEP1996	
APVD			NAME
PRODUCT SPEC			PINHEADER: 3 POS.; MQS Stiftwanne; 3pol.; MQS
PRODUCT SPEC			
APPLICATION SPEC			
VERARBEITUNGSSPEZ.			
SIZE	CAGE CODE	DRAWING NO.	RESTRICTED TO
A1	00779	967162	NUR FÜR
CUSTOMER DRAWING			REV. A3

SCALE: 5:1
SHEET 1 OF 1