

THIS DRAWING IS UNPUBLISHED. RELEASED FOR PUBLICATION 2005  
 © COPYRIGHT 2005 BY TYCO ELECTRONICS CORPORATION. ALL RIGHTS RESERVED.

LOC	DIST	REVISIONS			
P	LTR	DESCRIPTION	DATE	DWN	APVD
A1	-				

# ERGOCRIMP DIE SET FOR MCON 2.8LL TERMINALS / 1,5-2,5 mm<sup>2</sup>

Ergocrimp Matrize als Ersatzteil erhaeltlich  
 PN 9-1579021-2  
 Ergocrimp die set as spare part available  
 PN 9-1579021-2

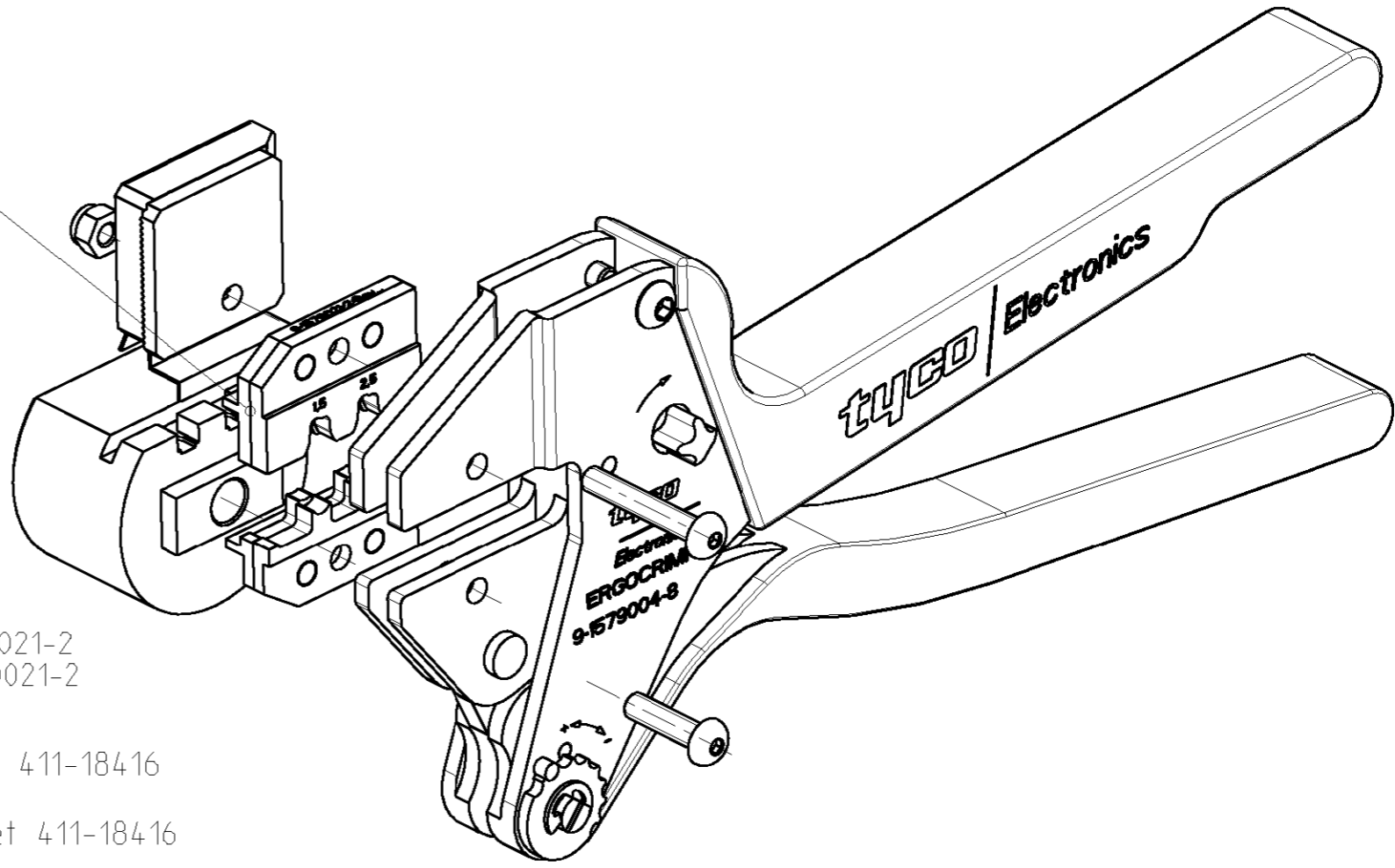

Einzelzeile der Ergocrimp Matrize bestellbar. Siehe Zeichnung PN 9-1579021-2  
 Spare parts of the Ergocrimp die set available. See drawing PN 9-1579021-2

Handzange mit Matrize zusammengebaut und mit Bedienungsanleitung 411-18416  
 im Karton verpackt  
 Hand tool assembled with die set and packed with instruction sheet 411-18416  
 in a cardboard

Kontakt	DGB (mm <sup>2</sup> )	Drahtcrimp / Wire Crimp		Isolationscrimp/Insulationcrimp		Isol.∅	Betriebsanl.
Contact	Wire Range	Hoehe/Height mm	Breite/Width mm	Hoehe/Height mm	Breite/Width mm	Ins.Range	Instr.Sheet
1719841	1,50	1,48 ±0,05	2,79 F	3,20	3,94 0V	2,2-2,4	411-18416
	2,50	1,77 ±0,05		3,30		2,7-3,0	

<small>THIS DRAWING IS A CONTROLLED DOCUMENT FOR TYCO ELECTRONICS CORPORATION                  IT IS SUBJECT TO CHANGE AND THE CONTROLLING ENGINEERING ORGANIZATION                  SHOULD BE CONTACTED FOR THE LATEST REVISION.</small>		DWN Ch.Witt 03MAY2007 CHK - APVD - PRODUCT SPEC - APPLICATION SPEC - WEIGHT 750 g		<b>tyco Electronics</b> tyco Electronics AMP GmbH D - 64625 Bensheim	
DIMENSIONS: mm 		TOLERANCES UNLESS OTHERWISE SPECIFIED: 0 PLC ± 1 PLC ± 2 PLC ± 3 PLC ± 4 PLC ± ANGLES ±° MATERIAL - FINISH -		NAME ERGOCRIMP HAND TOOL FOR MCON 2.8LL/1,5-2,5 mm <sup>2</sup> SIZE A3 CAGE CODE 00779 DRAWING NO C-9-1579004-8 RESTRICTED TO -	
CUSTOMER DRAWING			SCALE 1:1	SHEET 1 OF 1	REV A