

MODEL 8042-AR/-AP SUBMERSIBLE ACCELEROMETER



SPECIFICATIONS

- ◆ Submersible Accelerometer
- ◆ 4-20mA Output Signal
- ◆ True RMS or Peak Output
- ◆ IP68 Protection, >100meters
- ◆ Integral Cable, Tefzel & Urethane

DIMENSIONS

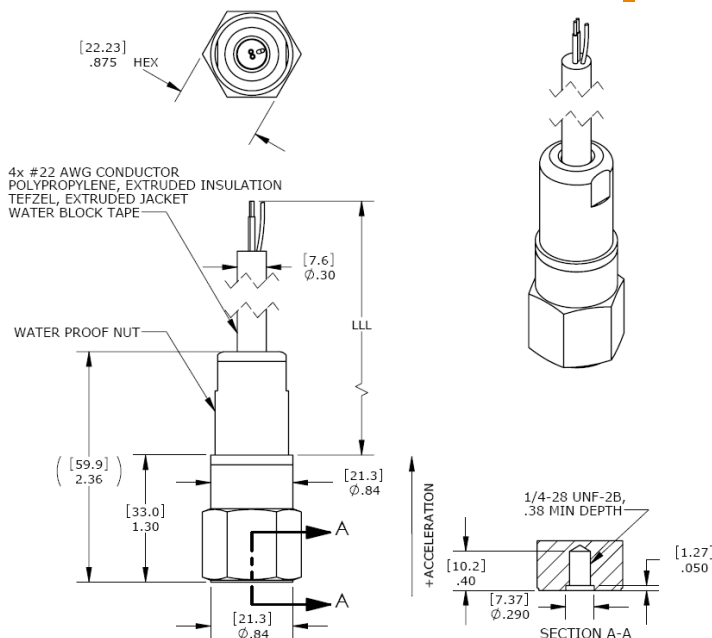

The Model 8042-AR/AP is a submersible accelerometer designed for harsh environments. The accelerometer is available in ranges from $\pm 5g$ to $\pm 100g$, in either 4-20mA RMS or Peak acceleration output options, and features a welded Titanium housing. The model 8042 features an integral cable that is custom designed for submersible applications and features a unique water block feature that self-seals in the event of accidental cuts to the cable.

The accelerometer includes internal shielding and a wide usable bandwidth to 5000Hz.

FEATURES

- ◆ $\pm 5g$ to $\pm 100g$ Dynamic Ranges
- ◆ 3-5000Hz Bandwidth
- ◆ Case Isolated, Internally Shielded
- ◆ Welded Titanium
- ◆ Annular Shear Mode Crystals
- ◆ Reverse Wiring Protection

APPLICATIONS

- ◆ Submersible Pumps
- ◆ Rotating Machinery Monitoring
- ◆ Underwater Vibration Monitoring
- ◆ Outdoor, Harsh Environments
- ◆ Gearbox Monitoring
- ◆ Shipboard Installations

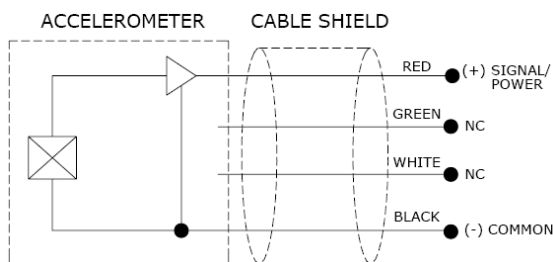

PERFORMANCE SPECIFICATIONS

All values are typical at +24°C, 100Hz and 15Vdc excitation unless otherwise stated. Measurement Specialties reserves the right to update and change these specifications without notice. Standard product parameters are described in PSC-1003 for Plug & Play AC Accelerometers.

Measurement Specialties family of [Piezoelectric Accelerometers](#) are used for vibration/shock monitoring, structural analysis, impact detection and machine monitoring.

Parameters

DYNAMIC

	±5	±10	±20	±50	±100	Notes
Range (g Peak or RMS)	±5	±10	±20	±50	±100	
Output (mA)	4 to 20	4 to 20	4 to 20	4 to 20	4 to 20	See Note 1
Frequency Response (cpm)	180-300000	180-300000	180-300000	180-300000	180-300000	±10%
Frequency Response (Hz)	3-5000	3-5000	3-5000	3-5000	3-5000	±10%
Non-Linearity (%FSO)	±1	±1	±1	±1	±1	
Transverse Sensitivity (%)	<5	<5	<5	<5	<5	
Shock Limit (g)	5000	5000	5000	5000	5000	

ELECTRICAL

Excitation Voltage (Vdc)	12 to 30					
Loop Resistance (Ohms)	900 max					See Note 2
Turn on Time (sec)	<15					
Grounding	Case Isolated, Internally Shielded					

ENVIRONMENTAL

Temperature Response (%)	±5
Operating Temperature (°C)	-20 to +80 for T (Tefzel) option cable -20 to +60 for U (Urethane) option cable
Protection Rating	IP68, 100meter minimum submersion

PHYSICAL

Sensing Element	Ceramic (shear mode)
Case Material	Titanium
Weight (grams)	70
Mounting Torque	24 lb-in (2.7 N-m)

Calibration supplied: CS-FREQ-0100 NIST Traceable Amplitude Calibration from 20Hz to ±10% Frequency Response Limit

Supplied accessories: AC-A03663 ¼-28 to ¼-28 mounting stud

Optional accessories: AC-D03664 ¼-28 to M5 mounting stud
AC-D03665 ¼-28 to M6 mounting stud
AC-A04209 Magnetic Mounting Adaptor
AC-D04210 Adhesive Mounting Adaptor

Note 1

The signal output from the 8042 sensor can be calculated using the following formulas.

$$\text{Vibration Level in G's} = (\text{Signal Output in mA} - 4\text{mA}) \times (\text{Full Scale Range in G's} / 16\text{mA})$$

Typical outputs are illustrated in the tables below.

Signal Output	8042-AR & 8042-AP Accelerometer Ranges				
	5g	10g	20g	50g	100g
4mA	0.00g	0.00g	0.0g	0.0g	0.0g
8mA	1.25g	2.50g	5.0g	12.5g	25.0g
12mA	2.50g	5.00g	10.0g	25.0g	50.0g
16mA	3.75g	7.50g	15.0g	37.5g	75.0g
20mA	5.00g	10.0g	20.0g	50.0g	100.0g

Note 2

$$\text{Maximum Loop Resistance} = (\text{Excitation Voltage} - 12\text{Vdc}) / 20\text{mA}$$

ORDERING INFORMATION

PART NUMBERING Model Number+Output Type+Range+Cable Option+Cable Length

8042-XX-GGG-TZZZ
| | | | Cable Length (0360 is 360 inches)
| | | Cable Jacket Option (T is Tefzel, U is Urethane)
| | Range (080 is 80g)
| Range Type (AR is RMS Acceleration)
-XX
AR = RMS
AP = Peak

Example: 8042-AR-080-U0360
Model 8042, RMS Acceleration Output, 80g Range, Urethane Cable, 360 inch (30ft) Cable Length

NORTH AMERICA

Measurement Specialties, Inc.,
a TE Connectivity Company
Tel: 800-522-6752
Email: customercare.hmpt@te.com

EUROPE

MEAS France SAS
a TE Connectivity Company
Tel: 800-440-5100
Email: customercare.lcsb@te.com

ASIA

Measurement Specialties (China), Ltd.,
a TE Connectivity Company
Tel: 0400-820-6015
Email: customercare.shzn@te.com

TE.com/sensorsolutions

Measurement Specialties, Inc., a TE Connectivity company.

Measurement Specialties, TE Connectivity, TE Connectivity (logo) and EVERY CONNECTION COUNTS are trademarks. All other logos, products and/or company names referred to herein might be trademarks of their respective owners.

The information given herein, including drawings, illustrations and schematics which are intended for illustration purposes only, is believed to be reliable. However, TE Connectivity makes no warranties as to its accuracy or completeness and disclaims any liability in connection with its use. TE Connectivity's obligations shall only be as set forth in TE Connectivity's Standard Terms and Conditions of Sale for this product and in no case will TE Connectivity be liable for any incidental, indirect or consequential damages arising out of the sale, resale, use or misuse of the product. Users of TE Connectivity products should make their own evaluation to determine the suitability of each such product for the specific application.

© 2015 TE Connectivity Ltd. family of companies All Rights Reserved.