

PART NUMBER	REV	FIRST USED
680477-1	A	122500-1
680477-2	A	565435-5

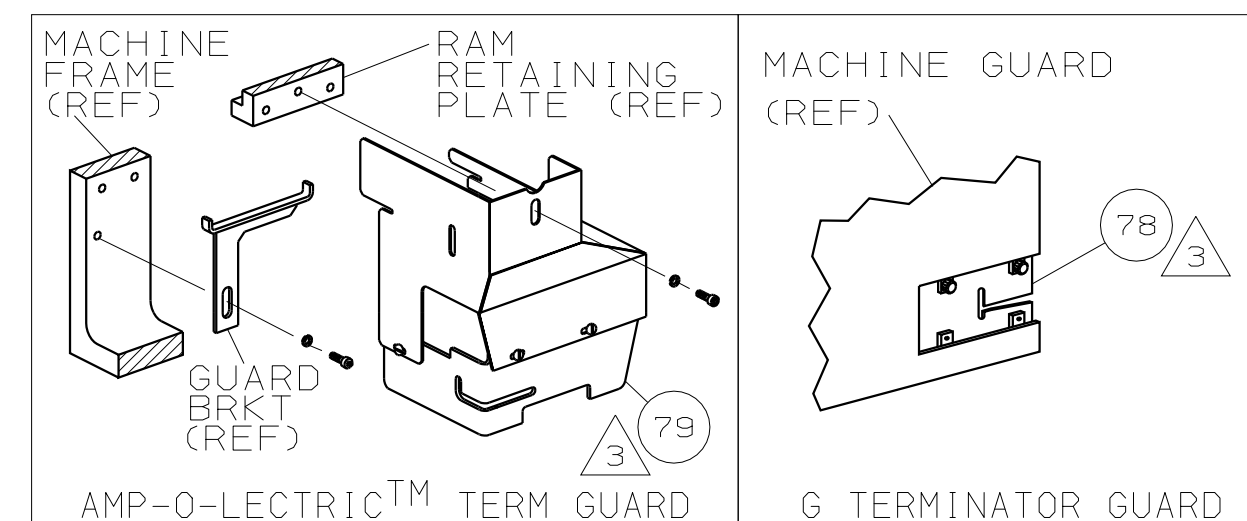

TERMINAL NAME: CONTACT, TWIN LEAF		CRIMPING DATA	
PAD LTR	CRIMP HEIGHT	WIRE SIZE	
A	.103 ±.002 [2.62 ±0.05mm]	10	
B	.087 ±.002 [2.21 ±0.05mm]	12	
C	.079 ±.002 [2.0 ±0.05mm]	14	
D	.071 ±.002 [1.8 ±0.05mm]	16	

CRIMP	SIZE	TYPE	RANGE
WIRE	.160 [4.06mm] .130 [3.30mm]	F	12-10 16-14
INSUL	-	-	-

WIRE STRIP LENGTH	TERM APPL SPEC	FEED	APPL INSTRUCTION	SET UP GAGE	LAYOUT
.234-.250	NONE	1.120	408-8039	458638-1	L1962

QTY	REV	U/M	DWG SIZE	PART NO	DESCRIPTION	ITEM NO
1	-	-	-	692655-5	AIR FEED VALVE ASSY	70
1	1	-	-	461690-1	SPACER, AIR FEED	68
REF	-	-	-	24042-2	VALVE, SHUT OFF	67
REF	-	-	-	692655-6	AIR FEED VALVE ASSY	66
1	1	-	-	460277-2	AIR FEED ASSY (2 INCH)	65
2	2	-	-	4-21000-3	SCR,SHC (10-32x2.00)AIR ASSY	64
-	1	-	-	983427-6	ELBOW, SWIVEL 1/8 NPT - 1/4 T	63
-	1	-	-	23238-1	QUICK DISCONNECT	62
-	12.00	IN	-	27319-4	TUBING, POLY-FLO Ø.25	61
1	1	-	-	454220-1	CAP, RAM	59
1	1	-	-	453736-1	HOUSING	58
1	1	-	-	694433-7	PAWL, FEED	56
1	1	-	-	461062-1	FEED FINGER ASSY	53
-	1	-	-	22374-7	VALVE, QUICK EXHAUST	48
-	1	-	-	22304-1	NIPPLE, HEX 1/8 NPT	47
1	1	-	-	690191-1	PLUG, NYLON	45
1	1	-	-	455674-1	RAM	44
1	1	-	-	690125-1	WASHER, LAMINATED	43
1	1	-	-	1-690124-1	WASHER, RAM	42
1	1	-	-	7-21002-9	BOLT, CRIMPER (5/16-24x1.00)	41
1	1	-	-	690223-2	SPACER, INSULATION DISC	38
1	1	-	-	354777-1	WIRE DISC, PLASTIC	37
1	1	-	-	22480-5	WASHER, SPRING	36
1	1	-	-	690212-1	POST, RAM	35
2	2	-	-	1-22284-0	SPRING, DRAG	32
1	1	-	-	240793-1	LEVER, DRAG RELEASE	31
1	1	-	-	2-690451-6	SPACER, STRIPPER	28
1	1	-	-	240639-1	STRIPPER	27
1	1	-	-	904229-1	PLATE, BASE	26
1	1	-	-	240792-1	DRAG, TERMINAL	25
1	1	-	-	904228-1	PLATE, STRIP GUIDE	24
1	1	-	-	690438-4	GUIDE, STRIP (REAR)	19
1	1	-	-	3-458031-3	GUIDE, STRIP (FRONT)	18
1	1	-	-	904231-1	HOLDER, SHEAR	14
1	1	-	-	904230-1	SHEAR, FLOATING	13
1	1	-	-	5-22280-0	SPRING, SHEAR	12
1	1	-	-	690461-1	STOP, SHEAR	11
1	1	-	-	456410-5	CRIMPER, WIRE	10
1	1	-	-	904232-2	ANVIL	9
1	1	-	-	904232-1	ANVIL	8
1	1	-	-	356420-2	DEPRESSOR	7
1	1	-	-	455888-9	SPACER, CRIMPER	2
1	1	-	-	456414-2	CRIMPER, WIRE	1

THIS DRAWING IS A CONTROLLED DOCUMENT FOR AMP INCORPORATED. IT IS SUBJECT TO CHANGE AND THE CONTROLLING ENGINEERING ORGANIZATION SHOULD BE CONTACTED FOR THE LATEST REVISION.

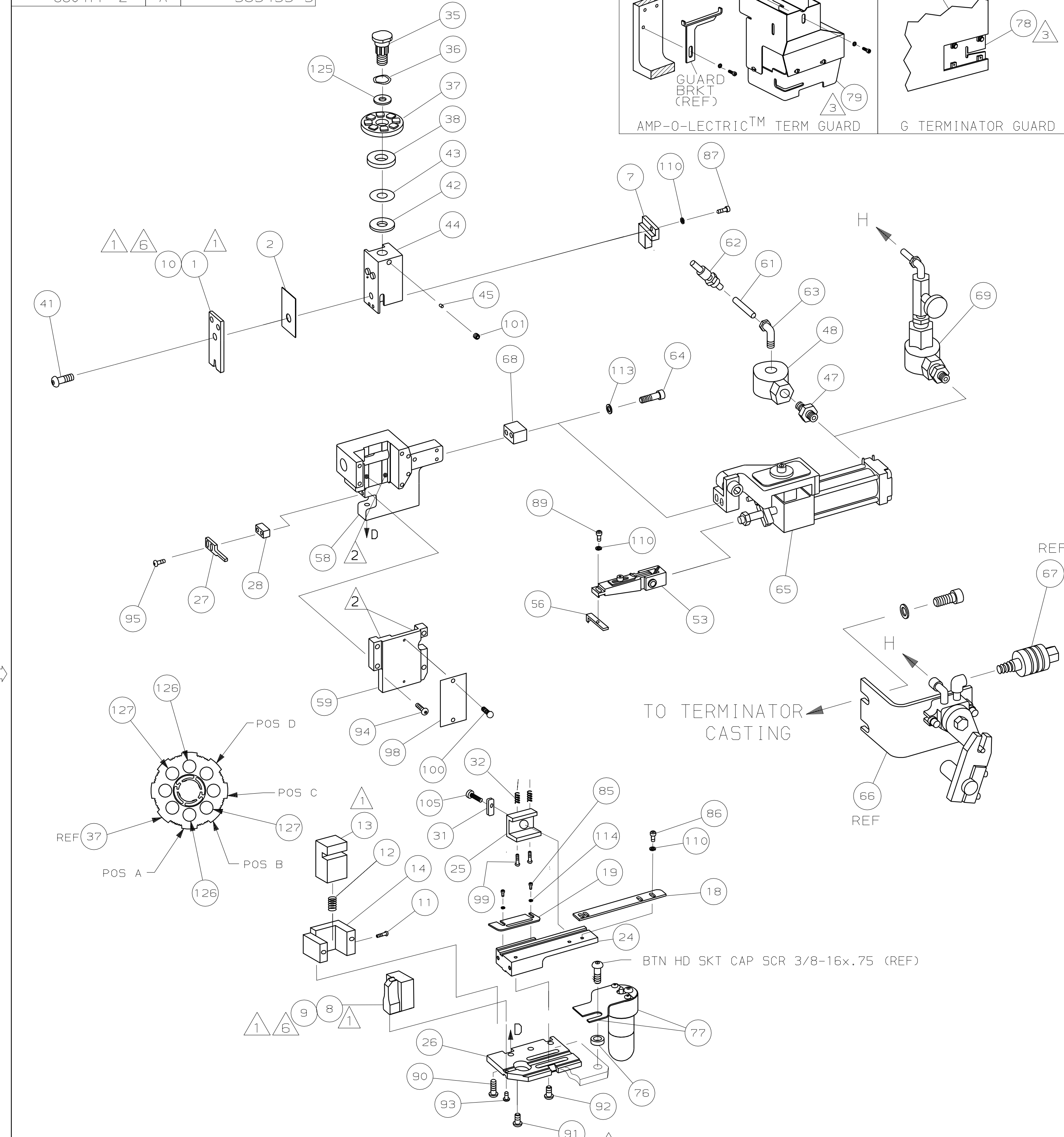

- 1 RECOMMENDED SPARE PARTS.
- 2 GREASE LIGHTLY.
- 3 GUARD MUST BE IN PLACE WHEN OPERATING APPLICATOR IN A BENCH MACHINE.
- 4 SEE DRAWING FOR COMPONENTS
- 5 ITEM 78 USED WITH G TERMINATOR ONLY.
- 6 286593-2 REQUIRES THIS CRIMP TOOLING AND THIS CRIMP INFORMATION TO BE USED DURING SET UP OF APPLICATOR.

QTY	REV	U/M	DWG SIZE	PART NO	DESCRIPTION	ITEM NO
2	2	-	-	8-354778-5	PIN, WIRE DISC (.2920)D	129
2	2	-	-	6-354778-6	PIN, WIRE DISC (.2825)C	128
2	2	-	-	5-354778-8	PIN, WIRE DISC (.2785)B	127
2	2	-	-	2-354778-1	PIN, WIRE DISC (.2600)A	126
1	1	-	-	986950-1	WASHER, FLAT PRECISION	125
1	1	-	-	217238-1	GENERAL INSTRUCTION PACKAGE	124
1	1	-	-	4088039	EF APPL INST 408-8039	123
						122
						121
						120
						119
						118
						117
						116
						115
2	2	-	-	21024-2	WASHER, LOCK (#4)RR STP GDE	114
2	2	-	-	21024-5	WASHER, LOCK (#10)AIR ASSY	113
						112
						111
4	4	-	-	21024-4	WASHER, LOCK (NO.8) SHEAR BL	110
						109
						108
						107
						106
1	1	-	-	22353-8	SCR, SHLD(Ø.187x.25)DRAG LEVER	105
						104
						103
						102
1	1	-	-	21009-2	SCR, SKT SET (1/4-20x.25)RAM	101
2	2	-	-	21017-2	SCR, DRIVE (#2x.19) ID PLATE	100
2	2	-	-	3-21002-0	SCR, BHC (10-32x.88)DRAG	99
1	1	-	-	461264-1	PLATE, IDENTIFICATION	98
						97
						96
2	2	-	-	2-21002-4	SCR, BHC (8-32x.75) STRIPPER	95
4	4	-	-	2-21002-9	SCR, BHC (10-32x.75) CAP	94
1	1	-	-	22733-8	SCR, BHC (8-32x.38 LW) ANVIL	93
4	4	-	-	3-21002-3	SCR, BHC (1/4-20x.50) ST GD PL	92
3	3	-	-	2-22733-8	SCR, BHC (1/4-20x.62)H5G	91
2	2	-	-	2-21002-2	SCR, BHC (8-32x.50) SHEAR HDR	90
1	1	-	-	2-22603-1	SCR, HEX HD (8-32x.38) FEED FGR	89
						88
2	2	-	-	2-21000-8	SCR, SHC (8-32x.62) DEPRESSOR	87
2	2	-	-	2-21000-7	SCR, SHC (8-32x.50) FT STP GUIDE	86
2	2	-	-	1-21000-3	SCR, SHC (4-40x.25) RR STP GUIDE	85
						84
						83
						82
						81
						80
1	-	-	-	455750-7	GUARD ASSY	79
-	REF	-	-	679532-1	INSERT, GUARD	78
1	-	-	-	465184-9	LUBRICATOR ASSY	77
1	-	-	-	454406-1	SPACER, LUB BRACKET	76
						75
						74
						73
						72
						71

LOC A
DIST 66

QTY	REV	U/M	DWG SIZE	PART NO	DESCRIPTION	ITEM NO
-2	-1	-	-			

REVISION OF EACH ASSY NO (WHEN BLANK, USE DWG REVISION)		PARTS LIST	
QTY	REV	U/M	DWG SIZE
-2	-1	-	-

DIMENSIONS IN INCHES. DO NOT SCALE PRINT.		MATL	HT TR	FIN
TOLERANCES UNLESS OTHERWISE SPECIFIED:		-	-	-
2 PLC DEC ±.25				
3 PLC DEC ±.125				
4 PLC DEC ±.0625				
ANGLES ±				
SURF TEXTURE: ✓				
REMOVE BURRS, BREAK SHARP EDGES R.015 MAX				

SCALE	DWG NO	REV	APPL
-	D	680477	A