

LOC	DIST	REVISIONS			
GP	00	REV	DATE	BY	CHK
		A	REV PER 0512-0650-04	22MAR2005	RG MP
		A1	REVISED	15FEB2013	ML SZ

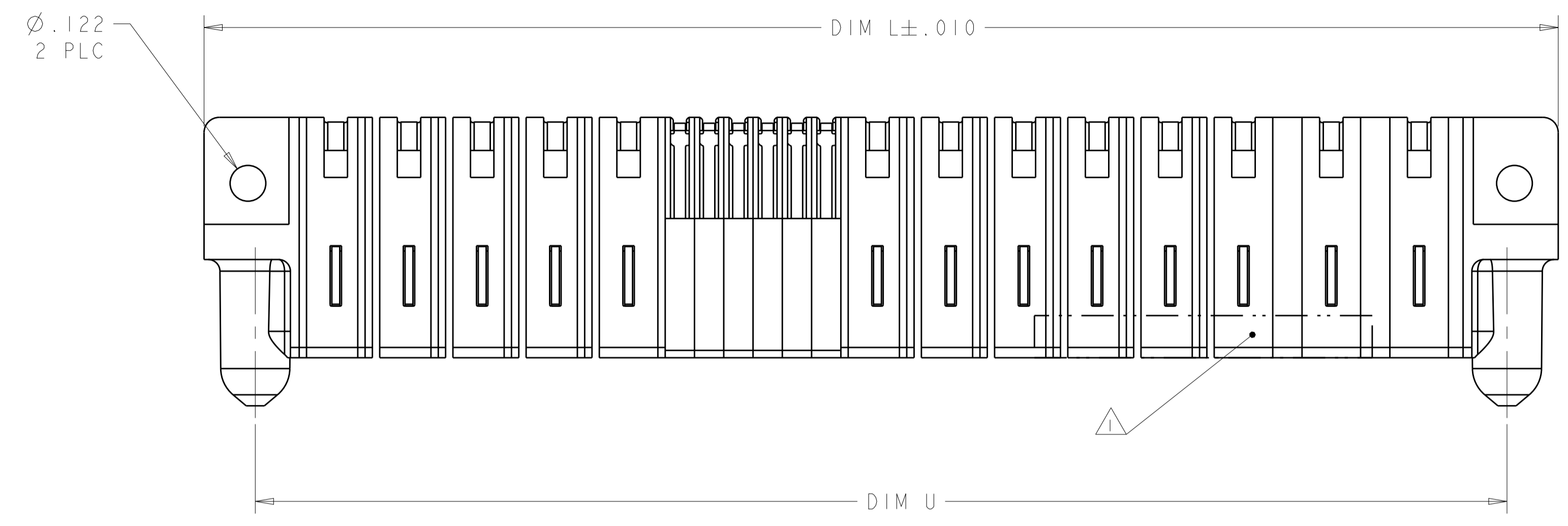

- △ "AMP", PART NUMBER AND DATE CODE TO BE MARKED IN AREA SHOWN.
- △ MATERIAL: HOUSING - GLASS FILLED HIGH TEMP THERMO PLASTIC, UL94 V-0
 SIGNAL CONTACTS - HIGH CONDUCTIVITY COPPER ALLOY
 POWER CONTACT - HIGH CONDUCTIVITY COPPER ALLOY
- △ CONTACT PLATING: NOBLE METAL PLATING ON CONTACT FUNCTIONAL AREA OF POWER AND SIGNAL CONTACTS
- △ MECHANICAL CONNECTOR KEEP OUT ZONE.
- △ DATUM AND BASIC DIMENSIONS ESTABLISHED BY CUSTOMER
- △ PCB - ALL HOLE DIAMETERS ARE FINISHED HOLE SIZES.
- △ PCB - .0453±.0010 DRILLED HOLES PLATED WITH .0003 MIN Sn OVER .001-.003 CU PLATING TO ACHIEVE .040±.003 DIAMETERS HOLE
- △ VARIABLE DIMENSIONS SHOWN ON VIEW (SHEET 2)

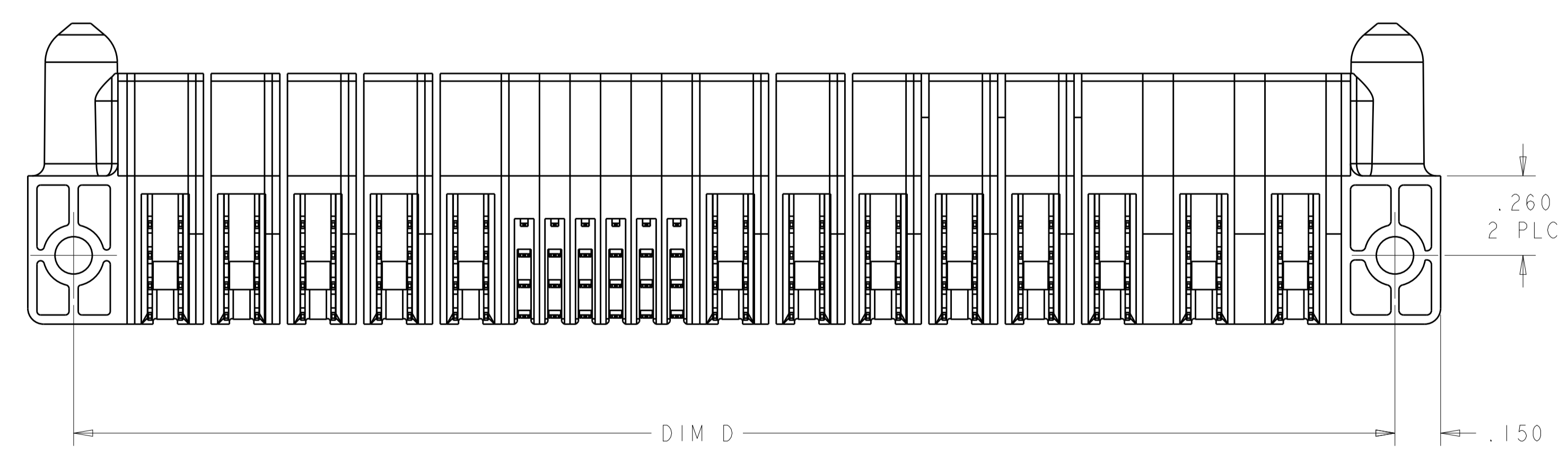
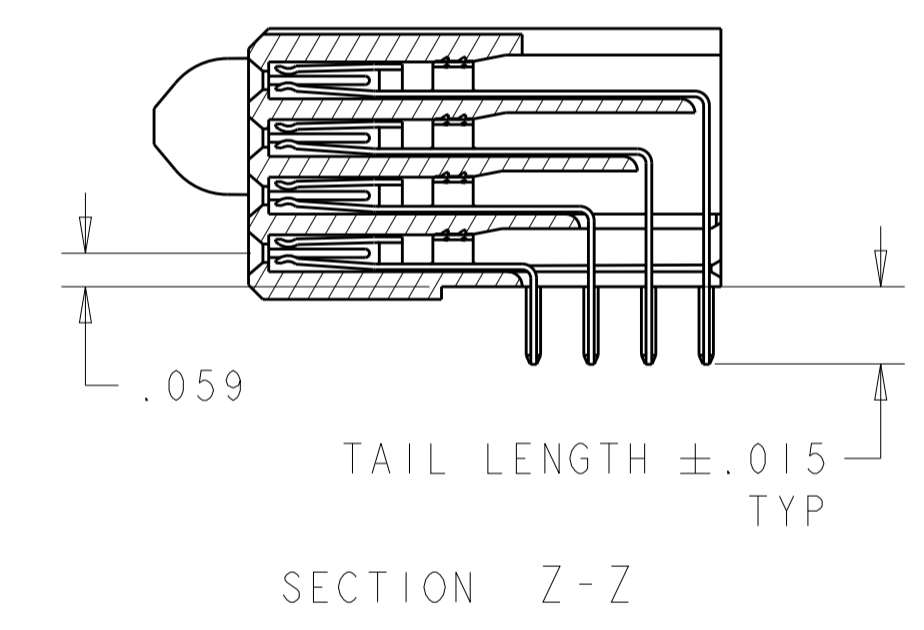
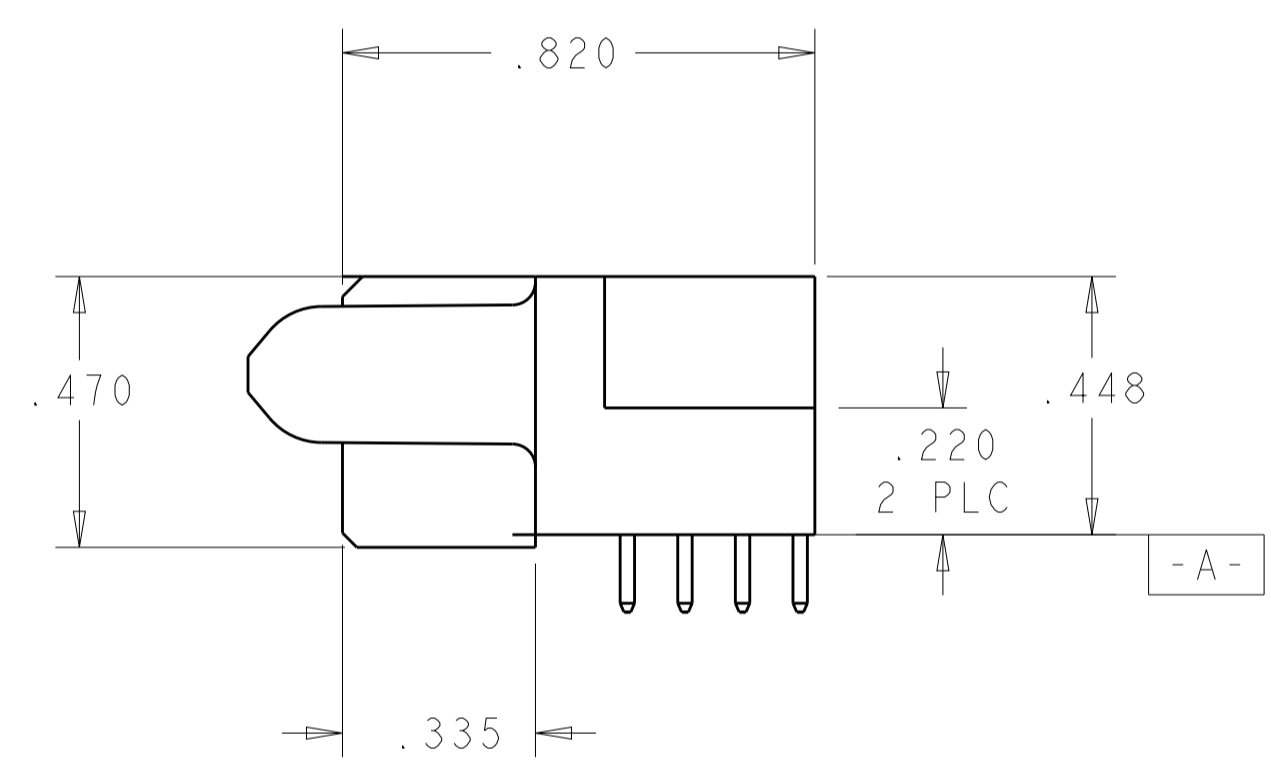
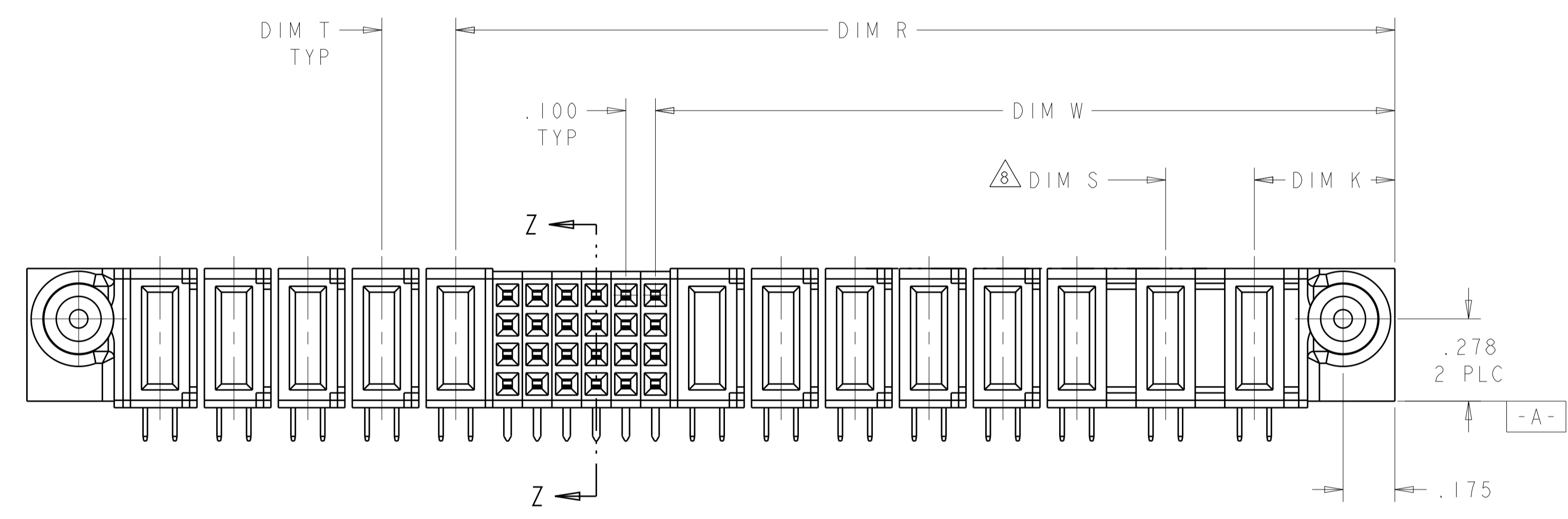

4.275	△	.250	3.175	2.500	4.325	-	4.625	.475	2ACP + 6P + 24S + 5P	6450270-1
DIM U	DIM S	DIM T	DIM R	DIM W	DIM D	DIM M	DIM L	DIM K	DESCRIPTION	PART NUMBER

THIS DRAWING IS A CONTROLLED DOCUMENT. DWG: R.GRZYBOWSKI 22MAR05
 CHK: M.PERCHEK 22MAR05
 APVD: M.PERCHEK

STE TE Connectivity

RIGHT ANGLE SOLDER RECEPTACLE ASSEMBLY MULTI-BEAMS XL

108-1973
 114-13038
 100779C=6450270

SCALE 4:1 SHEET 1 OF 2 REV A1

LOC	DIST	REVISIONS			
P	LTN	DESCRIPTION	DATE	DWN	APVD
-	-	SEE SHEET 1	-	-	-

PART NUMBER	ROWS	POWER					SIGNAL						POWER							
		P13	P12	P11	P10	P9	6	5	4	3	2	1	P8	P7	P6	P5	P4	P3	P2	P1
6450270-1	D C B A	RA	RM	RM	RM	RM	H	H	H	H	H	H	RM	RM	RM	RM	RA	RA	RM	RM
							G	G	G	G	G	G								
							F	F	F	F	F	F								
2ACP + 6P + 24S + 5P																				

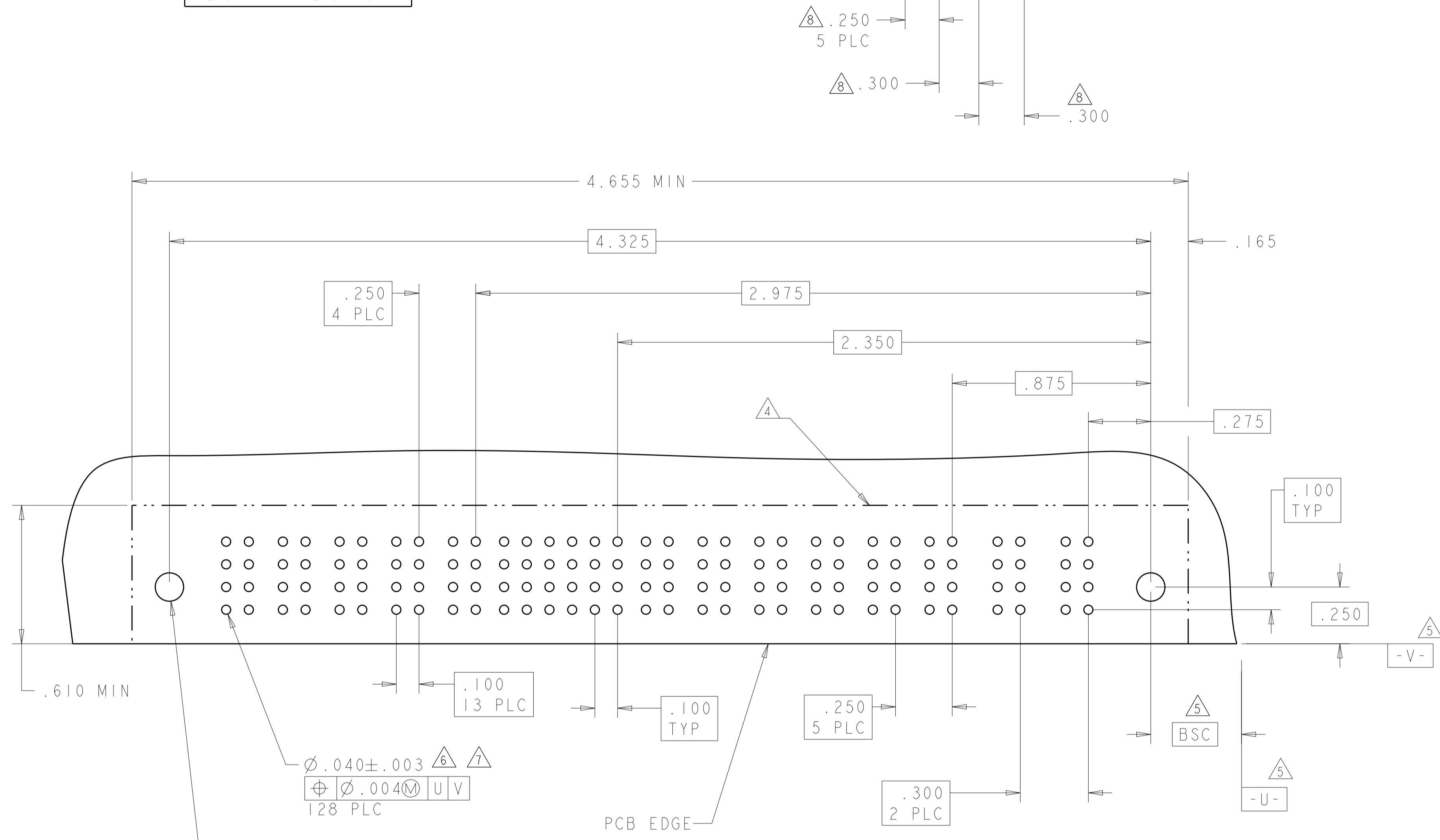

CODE	TAIL LENGTH	TYPE
RN	.090	STD
RB	.090	MFBL
RM	.135	STD
RA	.135	MFBL

POWER CONTACT

CODE	TAIL LENGTH	ROW
L	.090	D
K	.090	C
J	.090	B
I	.090	A
H	.135	D
G	.135	C
F	.135	B
E	.135	A

SIGNAL CONTACT

THIS DRAWING IS A CONTROLLED DOCUMENT.

DWN: R. GRZYBOWSKI 22MAR05
CHK: M. PERCHERKE 22MAR05
APVD: M. PERCHERKE

TE Connectivity

RIGHT ANGLE SOLDER RECEPTACLE ASSEMBLY MULTI-BEAMS XL

SIZE: A1 CAGE CODE: 114-13038 DRAWING NO: 6450270

SCALE: 4:1 SHEET: 2 OF 2 REV: A1