

THIS DRAWING IS UNPUBLISHED. RELEASED FOR PUBLICATION
 © COPYRIGHT - TE Connectivity Ltd. ALL RIGHTS RESERVED.

REVISIONS				
P	LTR	DESCRIPTION	DATE	APVD
A2		REVISED PER ECR-19-014370	27SEP2019	JA

- 1 CONTINUOUS STRIP ON REELS WITH TERMINALS LOCATED ON 5.59±0.08 [.220±.003] CENTERS.
- 2 SLOT TERMINATES EITHER SINGLE OR DOUBLE MAGNET WIRES OF THE SAME TYPE AND SIZE, COPPER RANGE IS 0.45-0.64mm [#25-#22] AWG EXCEPT 0.64mm [#22] AWG WHICH IS ONE WIRE ONLY SLOT ACCEPTS 0.57-0.72 mm[#23-#21] AWG ALUMINIUM SINGLE MAGNET WIRE ONLY. ALUMINIUM WIRE RANGE APPLIES FOR POST TIN PLATED PARTS ONLY.
- 3 0.0010 [.000040] MIN TIN PLATE.

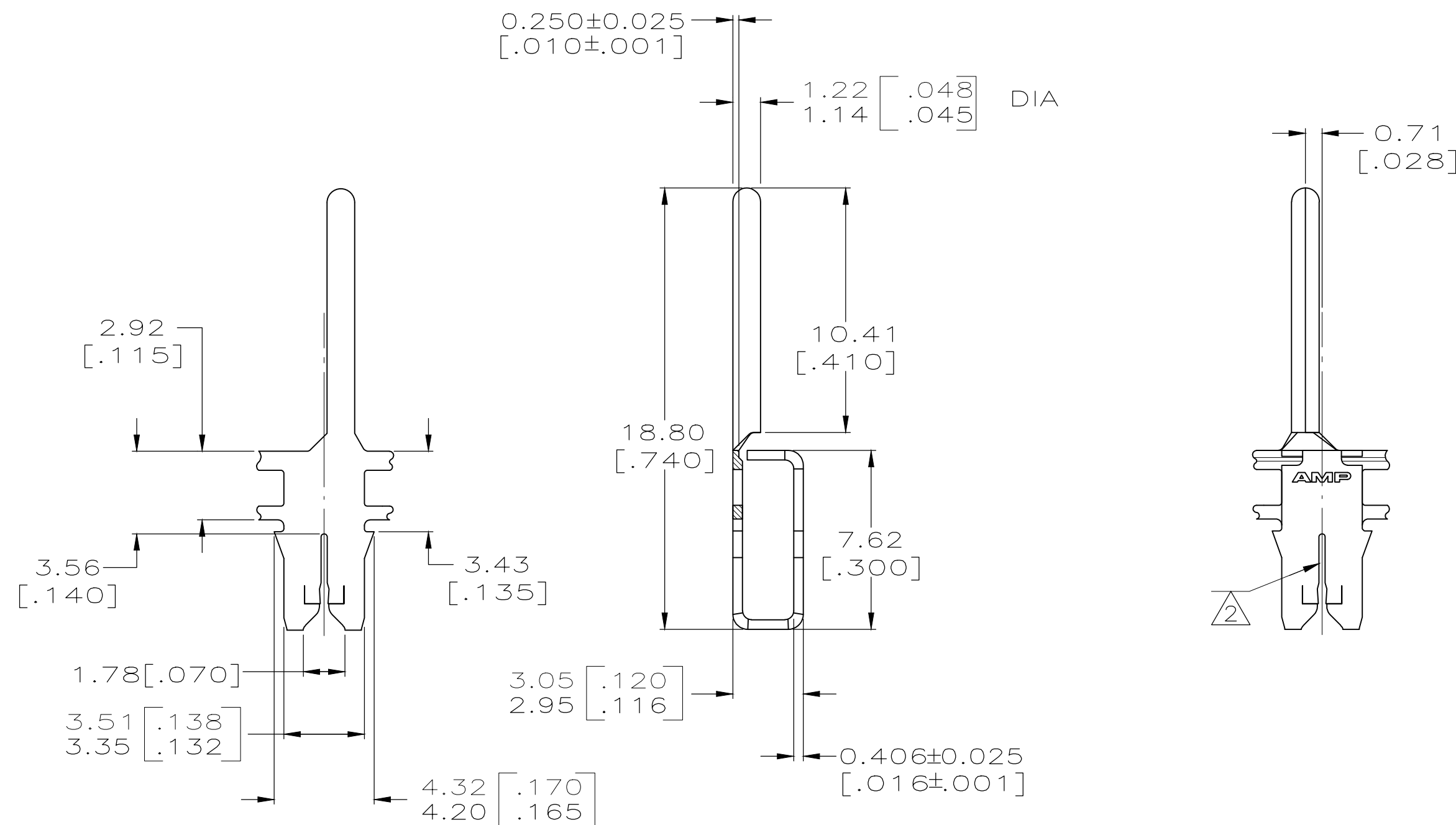

63788-1
PART NO

THIS DRAWING IS A CONTROLLED DOCUMENT.		DWN 18/FEB/94 MICHAEL S. FEHER		
DIMENSIONS: mm [INCHES]		CHK 21/FEB/94 PHILLIP M. FORTNEY		
TOLERANCES UNLESS OTHERWISE SPECIFIED:		APVD 23/FEB/94 TERRY L. SHUITER	NAME PIN, 1.22 [.048] DIA, LEFT HAND, MAG-MATE™	
0 PLC ± - 1 PLC ± - 2 PLC ± 0.15 [.006] 3 PLC ± - 4 PLC ± - ANGLES ± -		PRODUCT SPEC 108-2012	SIZE A2	CAGE CODE 00779
MATERIAL 4M PRE-MILLED BRASS		FINISH 3	WEIGHT 0	DRAWING NO C-63788
CUSTOMER DRAWING			SCALE 5:1	SHEET 1 of 1
			REV A2	RESTRICTED TO -