

THIS DRAWING IS UNPUBLISHED. RELEASED FOR PUBLICATION  
 © COPYRIGHT - By - ALL RIGHTS RESERVED.

LOC	DIST	REVISIONS					
AF	50	P	LTR	DESCRIPTION	DATE	DWN	APVD
			H	REVISED PER ECR-13-005733	26AUG2013	KH	PD

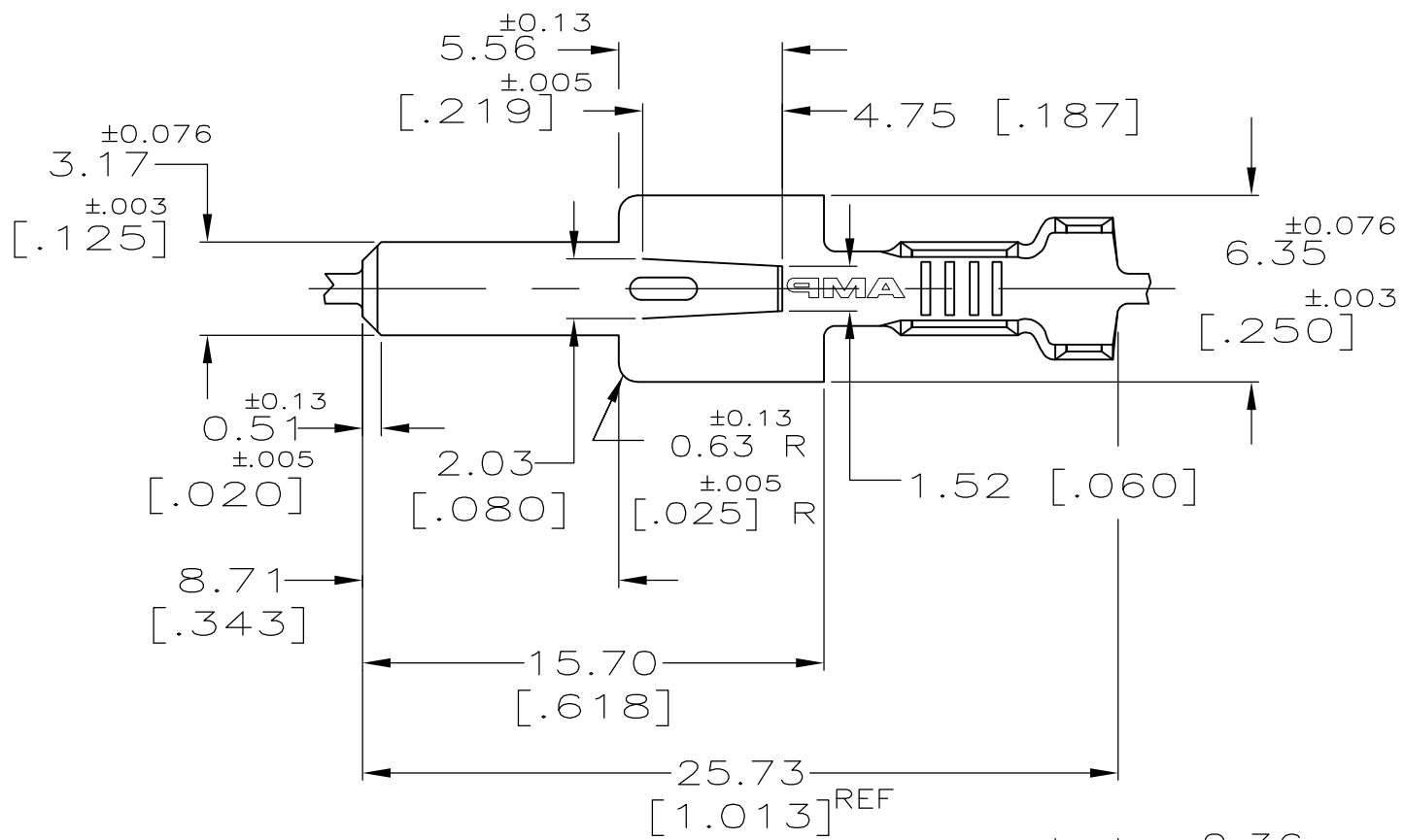

1 CONTINUOUS STRIP ON REELS

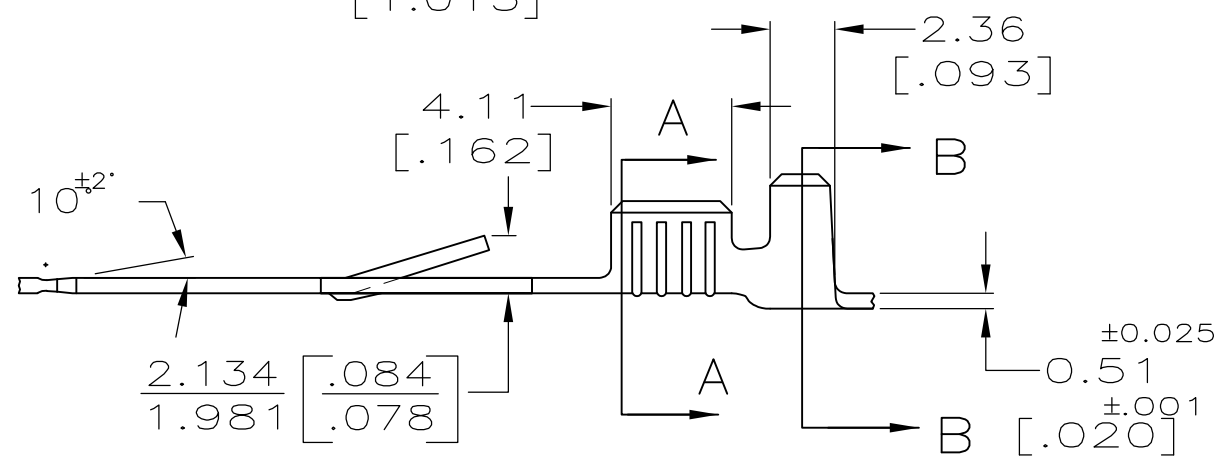
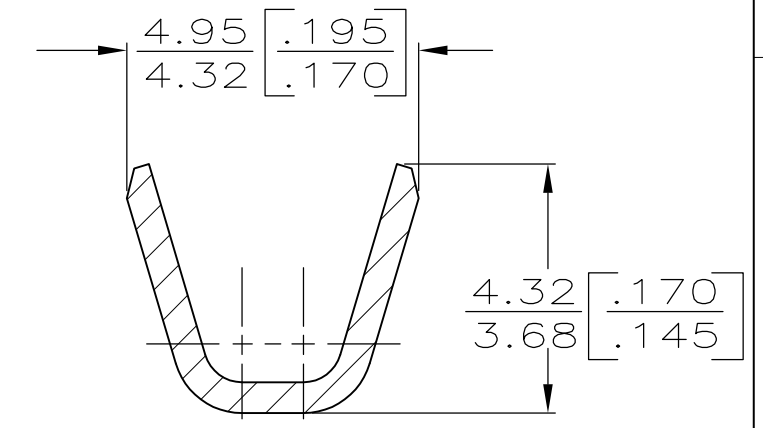
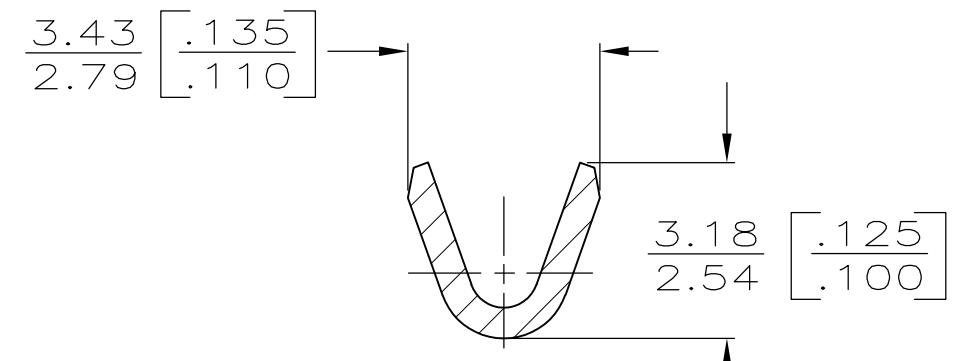

TIN	2.29-3.30 [.090-.130]	0.3-0.8mm <sup>2</sup> [22-18]	63580-1
FINISH	INSULATION RANGE	WIRE SIZE	PART NUMBER

0	3.94 [.155]	5.54 [.218]	F	2.29 [.090]	1.626 [.064]	0.8mm <sup>2</sup> [18]
					1.524 [.060]	0.5mm <sup>2</sup> [20]
					1.473 [.058]	0.3mm <sup>2</sup> [22]
TYPE	WIDTH	STRIP LENGTH #0.38 #[.015]	TYPE	WIDTH	#.051 [#.002] HEIGHT	WIRE
INSUL BARREL CRIMP			WIRE BARREL CRIMP			

THIS DRAWING IS A CONTROLLED DOCUMENT.

DIMENSIONS: mm [INCHES]

TOLERANCES UNLESS OTHERWISE SPECIFIED:

0 PLC ± -  
 1 PLC ± -  
 2 PLC ± -  
 3 PLC ± 0.25 [.010]  
 4 PLC ± -  
 ANGLES ± -

MATERIAL: T-2 ALLOY 688

FINISH: SEE TABLE

DWN: JR RUTH 5/9/90  
 CHK: MS FEHER 5/9/90  
 APVD: J GILLESPIE 5/9/90

STE TE Connectivity

NAME: TAB, FASTIN-FASTON, .125

PRODUCT SPEC: -  
 APPLICATION SPEC: -  
 WEIGHT: -

SIZE: A3 CAGE CODE: 00779 DRAWING NO: C-63580 RESTRICTED TO: -

CUSTOMER DRAWING SCALE: 4:1 SHEET: 1 OF 1 REV: H