

THIS DRAWING IS UNPUBLISHED. RELEASED FOR PUBLICATION ,19 .
 © COPYRIGHT 19 BY AMP INCORPORATED. ALL INTERNATIONAL RIGHTS RESERVED.

LOC		DIST		REVISIONS			DATE	APPD
AF	50	P	F	ZONE	LTR	DESCRIPTION		
					A	REL PER FASR, REV PER AF-6189	6/19/89	PWF/RPF

1 CONTINUOUS STRIP ON REELS

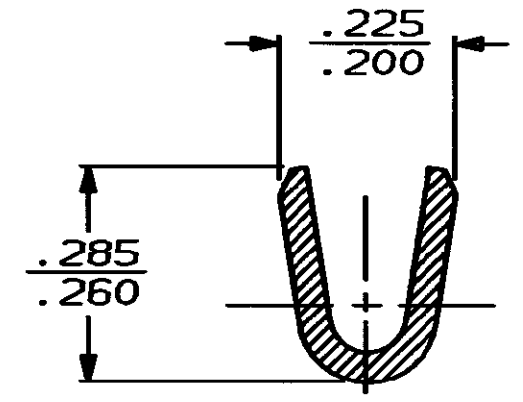
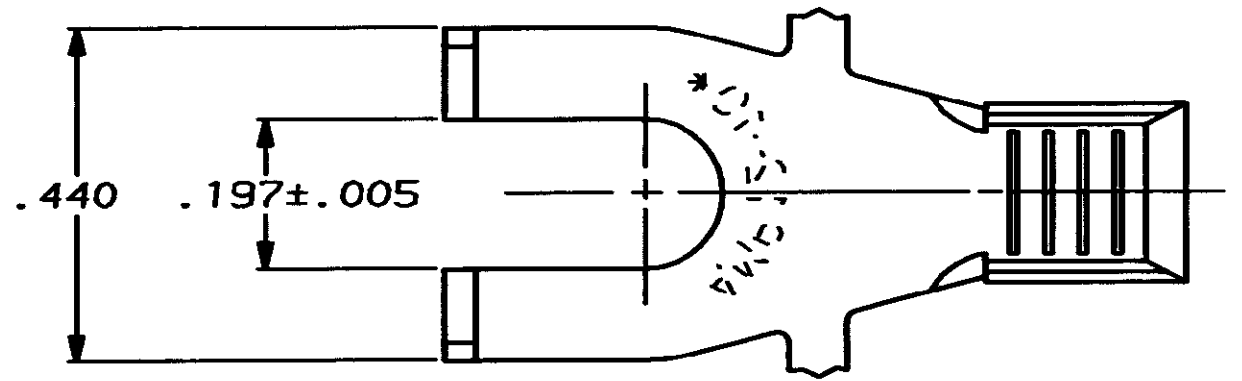

SECTION A-A

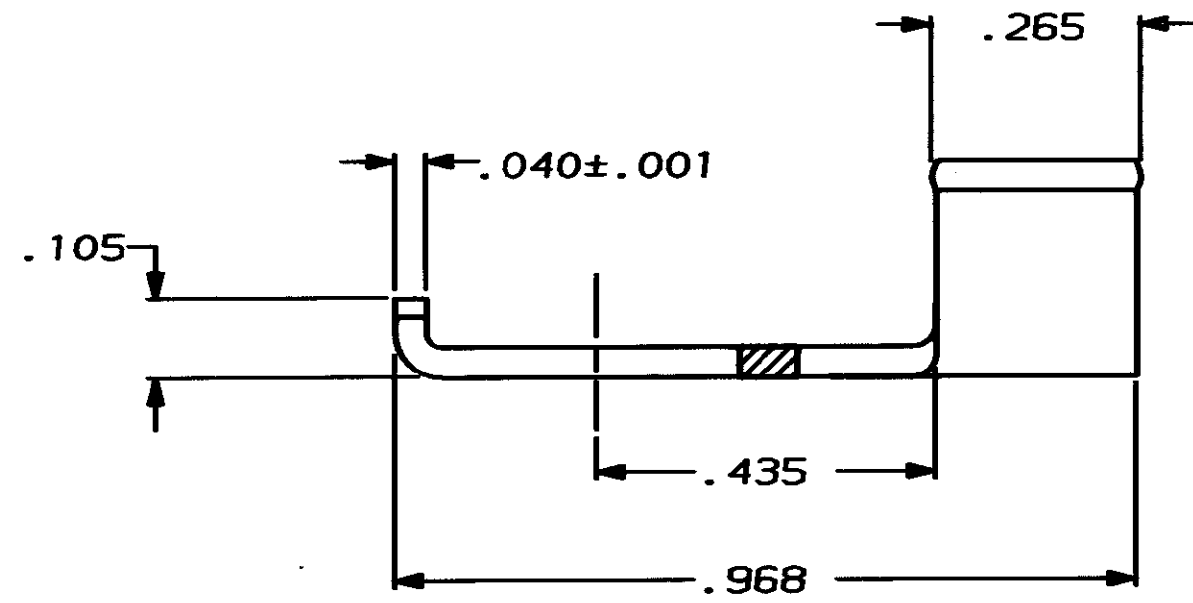

		#10	12-10	63526-1	
		STUD SIZE	WIRE SIZE	PART NO	
.288	F	.180	.149	10	DR P FORTNEY 2/22/89 CHK JR RUTH 2/25/89 APPD D DECKER 2/27/89 APPD TL SHUTTER 2/27/89 PRODUCT SPEC - APPLICATION SPEC - WEIGHT -
			.134	12	
STRIP LENGTH ±.015	TYPE	WIDTH	±.002 HEIGHT	WIRE	AMP INCORPORATED Harrisburg, Pa. 17105 TERMINAL, FLANGED SPADE
WIRE BARREL CRIMP					MATERIAL #1 HARD BRASS FINISH -
					SIZE B FSCN NO 00779 DRAWING NO 63526 SCALE 4:1 SHEET 1 OF 1

CUSTOMER DRAWING