

4

3

2

1

THIS DRAWING IS UNPUBLISHED. RELEASED FOR PUBLICATION, 19 .
 © COPYRIGHT 19 BY AMP INCORPORATED. ALL RIGHTS RESERVED.

| LOC | DIST | REVISIONS | | | |
|-----|------|-------------|--------------------------|---------|-------|
| P | LTR | DESCRIPTION | DATE | DWN | APVD |
| AF | 50 | B | REDRAWN PER 0L10-0027-98 | 1/29/98 | JR JW |

1 SUPPLIED IN LOOSE PIECE.

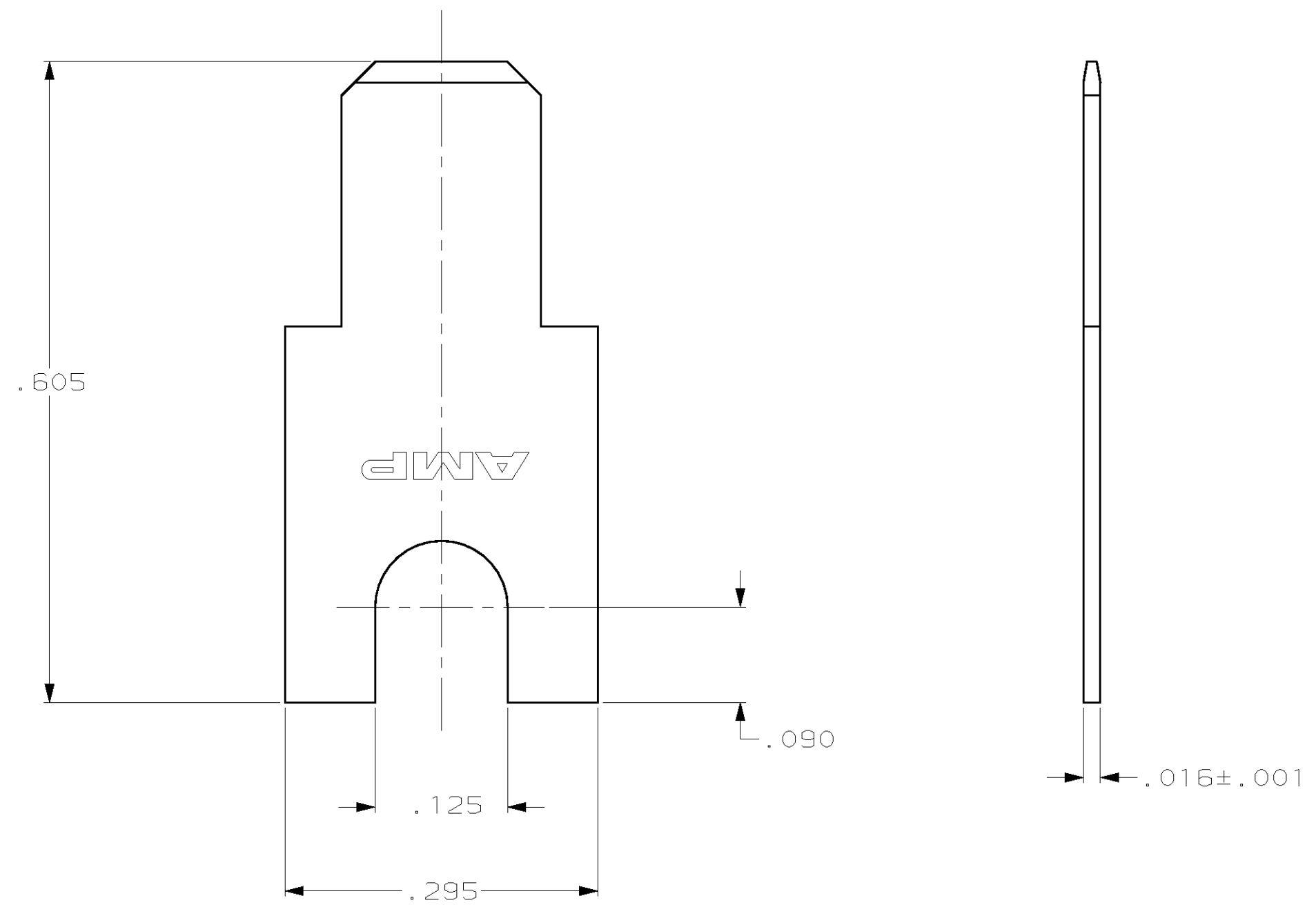

61066-1
PART NO.

| | | | | | |
|--|--|------------------|----------|---------------|---|
| THIS DRAWING IS A CONTROLLED DOCUMENT. | | DWN | JR RUTH | 1/29/98 | AMP Incorporated Harrisburg, PA 17105-3608 |
| DIMENSIONS: INCHES | | CHK | MS FEHER | 1/29/98 | |
| | | APVD | J WORMAN | 1/29/98 | |
| TOLERANCES UNLESS OTHERWISE SPECIFIED: | | PRODUCT SPEC | | NAME | |
| 0 PLC ±- 1 PLC ±- 2 PLC ±- 3 PLC ±.015 4 PLC ±- ANGLES ±- | | APPLICATION SPEC | | SIZE | A3 |
| MATERIAL | | WEIGHT | | CAGE CODE | 00779 |
| 082 BRASS | | - | | DRAWING NO | C- 61066 |
| FINISH | | CUSTOMER DRAWING | | RESTRICTED TO | - |
| .000080 MIN TIN | | SCALE | | SHEET | 1 OF 1 |
| | | 8:1 | | REV | B |