

THIS DRAWING IS UNPUBLISHED. RELEASED FOR PUBLICATION
 © COPYRIGHT - TE Connectivity ALL RIGHTS RESERVED.

REVISIONS					
REV	DESCRIPTION	DATE	OWN	APP'D	
AK2	REVISED PER ECR-17-013047	12SEP17	J.Z	D.Z	

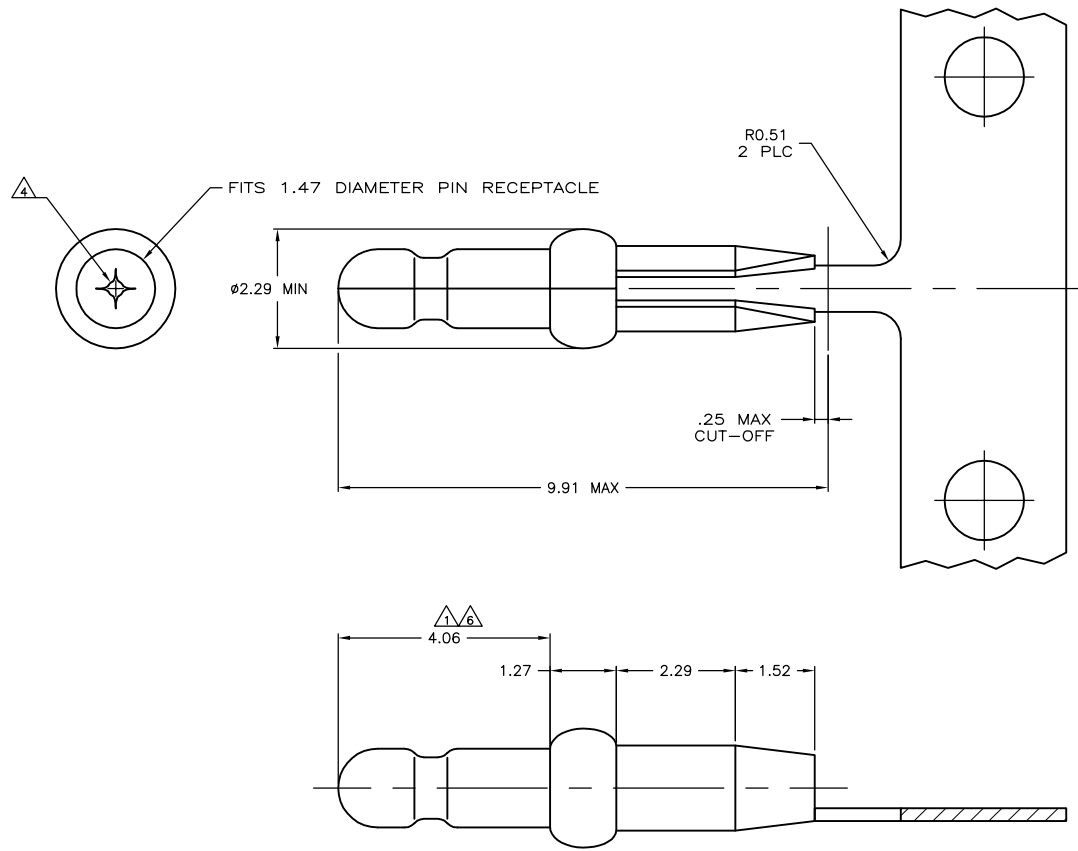

- ⚠ 0.00076 MIN GOLD PLATING IN THIS AREA WITH 0.00381 MIN MATTE TIN LEAD ON THE REMAINDER, BOTH OVER 0.00127 MIN NICKEL UNDERPLATE.
- 2. FITS 1.47 - 1.57 DIAMETER HOLE IN A 1.57 OR 2.36 PRINTED CIRCUIT BOARD.
- 3. PARTS TO COMPLY WITH AMP SOLDERABILITY SPECIFICATION 109-11-3.
- ⚠ 0.05 - 0.25 DIAMETER OPENING REQUIRED IN TIP OF PIN.
- 5. APPLICATOR FEED: 8.00 - 8.26.
- ⚠ 0.00076 MIN GOLD PLATING IN THIS AREA WITH 0.00381 MIN MATTE TIN ON THE REMAINDER, BOTH OVER 0.00127 MIN NICKEL UNDERPLATE.

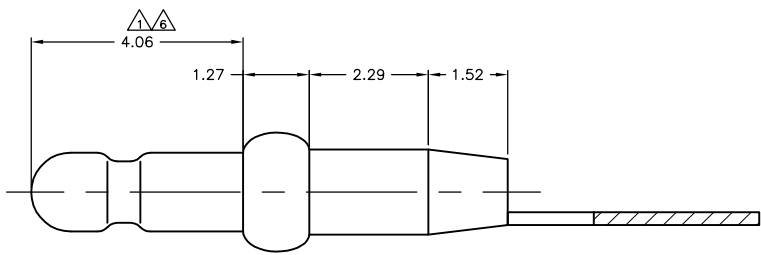
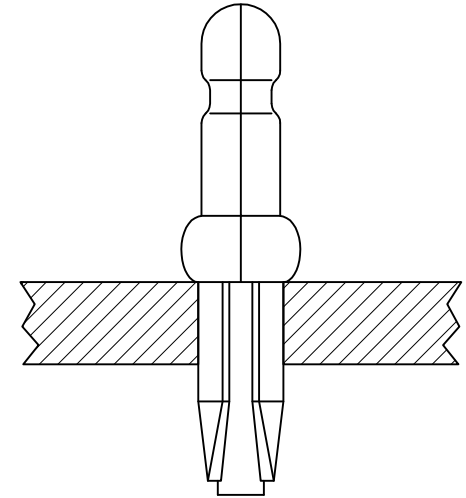

OBSOLETE	⚠	3-60809-2
	⚠	60809-2
	⚠	60809-1
	⚠	PART NUMBER

MM	IN	MM	IN	MM	IN	MM	IN
0.13	.005	1.52	.060	8.00	.315	-	-
0.05	.002	1.47	.058	4.06	.160	-	-
0.00381	0.000150	1.27	.050	2.36	.093	-	-
0.00127	0.000050	0.51	.020	2.29	.090	9.91	.390
0.00076	0.000030	0.25	.010	1.57	.062	8.26	.325

CONVERSION TABLE

METRIC

THIS DRAWING IS A CONTROLLED DOCUMENT.

OWN: T. BECK	29JUL97		TE Connectivity
CHK: R. SWING	29JUL97		PIN, .058 DIAMETER, PHOSPHOR BRONZE, PRESS FIT, P.C. CONTACT
DATE: A. REDDICK	10SEP97		NAME:
PRODUCT SPEC: 108-1025			APPLICATION SPEC: 114-1008
MATERIAL: 0.25 PH BRZ	FINISH: SEE TABLE	WEIGHT: 0.000000	SIZE: A2
		CAGE CODE: 00779	DRAWING NO: 60809
		CUSTOMER DRAWING	RESTRICTED TO: -
		SCALE: 15:1	SHEET: 1 of 1
		REV: AK2	