

THIS DRAWING IS UNPUBLISHED. RELEASED FOR PUBLICATION
 © COPYRIGHT BY TYCO ELECTRONICS CORPORATION. ALL INTERNATIONAL RIGHTS RESERVED.

LOC	DIST	REVISIONS			DAP		
P	LTR	DESCRIPTION	DATE	DWN	APVD		
G	14	B	REV PER ECR 09-026308	10DEC09	JR	TM	

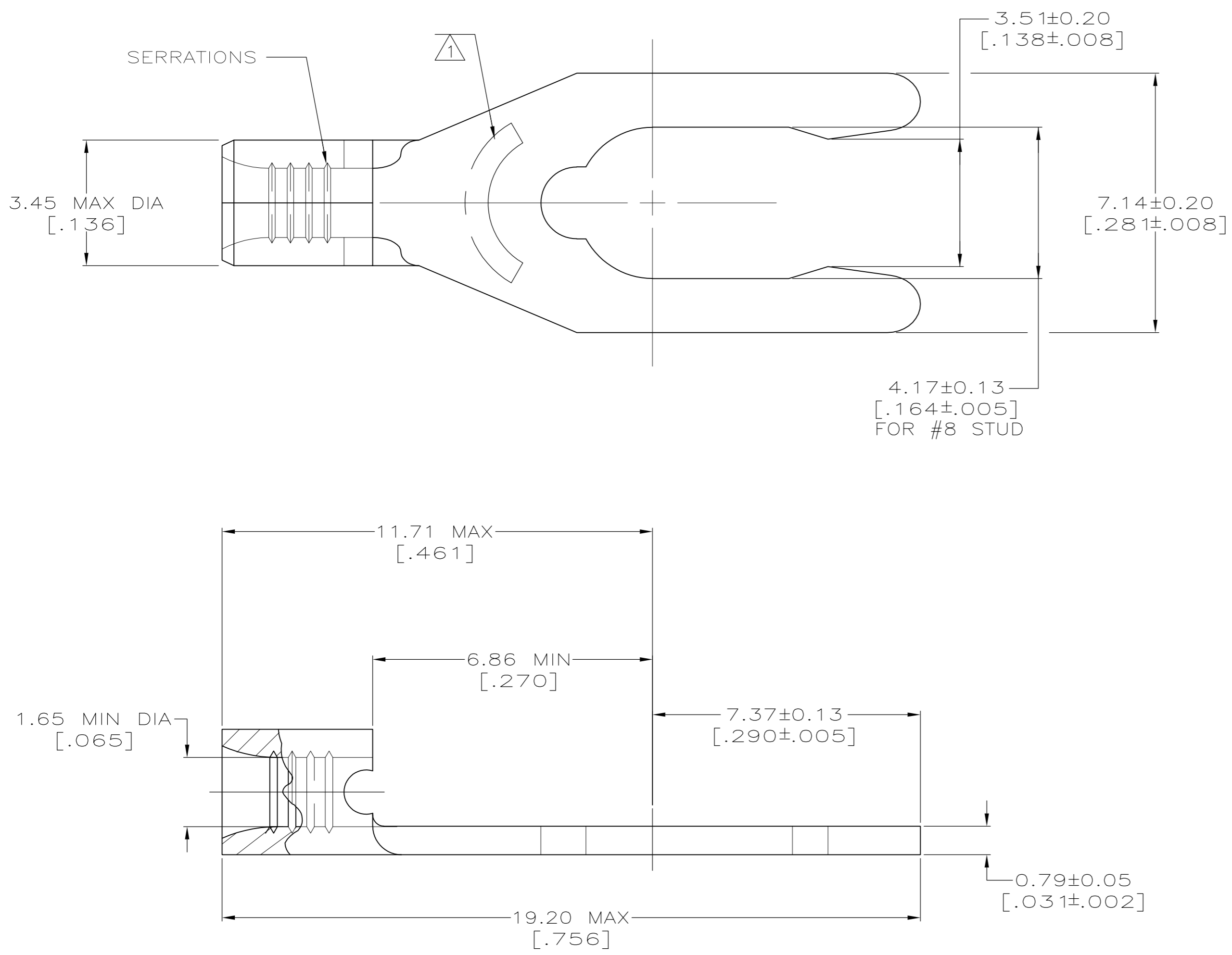

AMP WIRE RANGE	Listed FILE E13288	LR7189 Certified
22-16 AWG STRANDED	22-16 AWG STRANDED	NOT CERTIFIED

- 1 STAMP 8S AMP 22-18* APPROX AS SHOWN
22-16 TERMINALS ARE STAMPED 22-18 IN ACCORDANCE WITH MILITARY SPECIFICATION MIL-T-7928; COMMERCIAL WIRE RANGE IS 22-16 8S INDICATES STUD SIZE
- 2 PHOSPHOR BRONZE PER ASTM B-103, ANNEALED
- 3 TIN PLATE 0.00254 [.000100] MIN PER ASTM B-545
- 4 MAX RECOMMENDED OPERATING TEMP 170°C
- 5 WIRE CROSS SECTIONAL AREA RANGE:
0.26-1.65mm² [509-3,260] CIR MILS STRANDED

52701-1
PART NO.

THIS DRAWING IS A CONTROLLED DOCUMENT.		DWN TA BRINKMAN 2-15-93	Tyco Electronics Corporation Harrisburg, PA 17105-3608	
DIMENSIONS: MM [INCHES]		CHK DA PATTERSON 2-15-93	NAME JL MECKLEY	
TOLERANCES UNLESS OTHERWISE SPECIFIED:		APVD 2-15-93	PRODUCT SPEC	
0 PLC ± -		APPLICATION SPEC		
1 PLC ± -		WEIGHT		
2 PLC ± 0.20 [.008]		SIZE A2		
3 PLC ± -		CAGE CODE 00779		
4 PLC ± -		DRAWING NO C=52701		
ANGLES ± -		RESTRICTED TO		
FINISH		SCALE 10:1		
MATERIAL		SHEET 1 of 1		
- 2		REV B		
- 3		CUSTOMER DRAWING		