

6 Pins,1.6 Pitch,1 Piece BtoB Connector

1. Purpose:

This is qualification test. The purpose of this test is to evaluate the performance of 6 pin 1.6p B to B. Testing was performed on below products to determine it compliance with the requirements of product specification 108-115016-1 Rev. A.

2. Scope:

This is test report for 6 pins 1.6pitch BtoB connector. Testing was performed at Tyco Electronics Shanghai Electrical Components Test Laboratory between Jan 24, 2011 and Jun 02, 2011.

3. Conclusion:

The product met the electrical, mechanical, and environmental performance requirements of TE product specification 108-115016-1 REV A.

4. Test samples:

Samples were taken randomly from current production. The following part numbers were used for test:

Description	Product Part No.
6 Pins,1.6 Pitch,1 Piece BtoB Connector	1932771-1

5. Test Method

5.1 Examination of Product

Visual, dimensional and functional per applicable inspection plan.

Requirements: Meets requirements of product drawing

Test Method: In accordance with IEC 60512-1-1and IEC 60512-1-2.

5.2 Terminal Resistance (Low Level)

Measure at nominal working position (20 mV, 100 mA max.). Simple sketch shows the testing method. Four-wire measurement method.

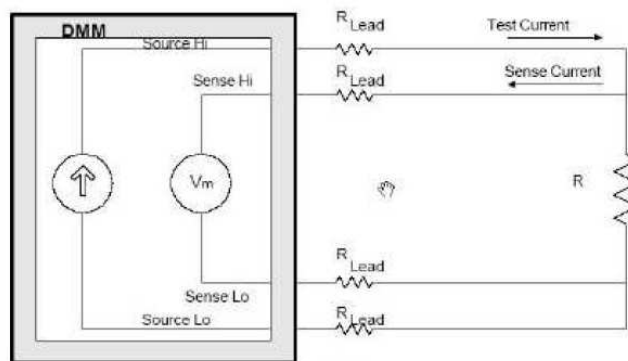

Figure 2 Termination Resistance Measurement Points

Requirements: 50mΩ Max. (Initial), 100mΩ Max. (Final)

Test Method: IEC 60512-2-1

5.3 Insulation resistance

Unmated connector with 100V DC between adjacent contacts for 1 min.

Requirements: 100 MΩMin.

Test Method: IEC 60512-3-1

5.4 Dielectric strength

Unmated connector with 400 V AC between adjacent contacts for 1 min. Leakage current 0.5mA

Requirements: No breakdown.

Test Method: IEC 60512-3-1

5.5 Temperature Rise

Measured at maximum rated current with series all contacts.

Current: 0.3A

Requirement: 1. 30°C Max.; 2. No mechanical damage

Test method: IEC 60512-5-2

5.6 Normal Force

First press to housing surface, then measure on second cycle. Max. value is read on up going curve and min. value is read on down going curve of force-deflection curve.

Requirements: ① 0.2N Min. :Compressed to 1.9mm to PWB surface;

② 1.0N Max.: Compressed to housing surface.

5.7 Terminal Retention Force

Draw out a contact on the solder tail, away from the housing max 5 mm / min.

Requirements: 0.5N Min.

5.8 Vibration, Random

Frequency: 10 - 100 Hz; 3 m2/s3(0.0132 g2/Hz) ;100 - 500 Hz; -3dB/Oct. for: 3 x 60 min (X- Y- and Zaxis) in minimum deflection position.

Requirements: ① Discontinuity max 1 us ② Resistance 100mOhm max. ③ No mechanical damage

Test method: IEC60068-2-64

5.9 Mechanical shock

Pulse shape half sine, peak acceleration 50 G, pulse 11 ms, 3 shocks in both directions in XYZ axis (18 shocks).

Requirements: ① Discontinuity max 1 us ② Resistance 100mOhm max. ③ No mechanical damage

Test method: IEC60068-2-27Ea

5.10 Durability

Mate contact up to 10 cycles to housing surface at the speed of max 20 times / min including pause between mate / unmate.

Requirements:① No mechanical damage

② Resistance 100mOhm max.

③ Normal Force:

--0.2N Min. : Compressed to 1.9mm to PWB surface;

--1.0N Max.: Compressed to housing surface.

5.11 Connector Peel Strength

A load in max 5 mm/min applied to the whole side of the connector on PWB. All four directions(X,Y) along PWB.

Requirements: Load 1N/Contact

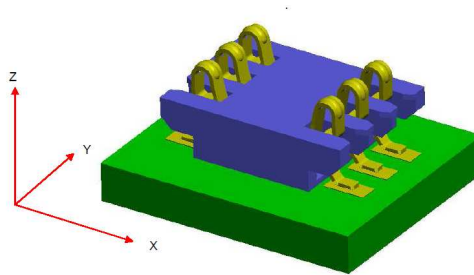

Figure 3

5.12 Thermal Shock

25cycle of Ta=-40°C for 0.5hour then change to 25°C max. 5min then Tb=+85°C for 0.5hour, then cool to ambient.

Recovery 2hour at ambient atmosphere.

Requirements: LLCR 100mΩ Max. (Final)

Test Method: IEC60068-2-14Na

5.13 Damp Heat Cyclic

18 cycles of 24 h in operational mode, mated condition, RH 90-100%, 25 -> 55 °C in 3 h, then maintain for 9 h, then 55 -> 25 °C in 3 h, maintain for 9 h. Recovery at 25 °C RH75% for 2h.

Measure resistance without opening the mating.

Requirements: LLCR 100mΩ Max. (Final)

Test Method: IEC60068-2-30Db

5.14 Condensing Humidity Cyclic

96 h in operational mode, mated condition, RH 90%, 60°C for 30 min -> then 60 to 10 °C in 25min, then maintain for 30 min , then 10 to 60°C in 20 min. This cycle profile is continued for 4days. Recovery at 25°C RH 75% for 2h.

Measure resistance without opening the mating.

Requirements: LLCR 100mΩ Max. (Final)

5.15 Dry Cold

At -40°C for 96 h, recovery 2 h at ambient atmosphere.

Requirements: LLCR 100mΩ Max. (Final)

Test Method: IEC60068-2-1Ab

5.16 Dry Heat

At 85°C for 96 h, recovery 2 h at ambient atmosphere.

Requirements: LLCR 100mΩ Max. (Final)

Test Method: IEC60068-2-2Bb

5.17 Resistance to soldering Reflow Heat

Test with reflow profile for soldering heat resistance described in Figure 1. Though over 3 times, first top side up, then twice up side down.

Requirements: No mechanical damage, no loosening of solder joint.

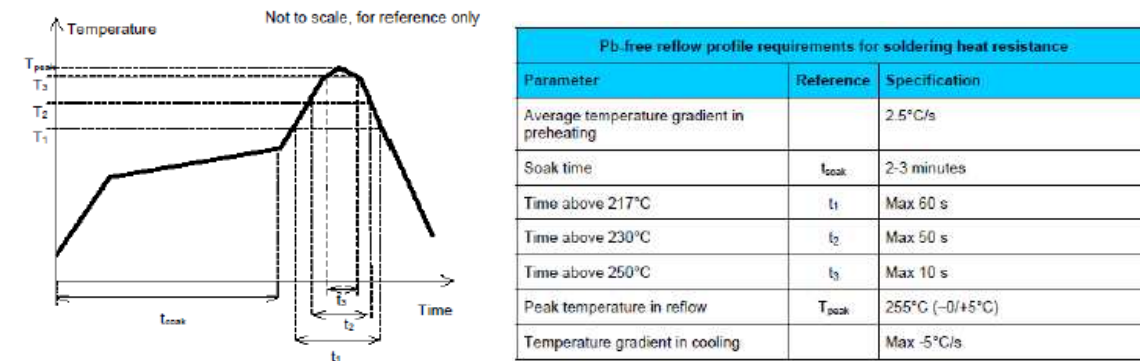

6. Unless otherwise stated, the following environmental conditions prevailed during testing:

Temperature: 15°C to 35°C Relative Humidity: 25% to 75%

7. Test Sequence

Test Examination	Test Group					
	A	B	C	D	E	F
	Test Sequence					
LLCR	1,4,6	1,9	1,4			
Insulation Resistance		2,10				
Dielectric strength		3,11				
Temperature rise vs. current.				2		
Normal Force		4,6				
Terminal retention force					1	
Random vibration	2					
Mechanical shock	3					
Durability		5				
Connector Peel Strength						1
Thermal Shock		7				
Damp Heat Cyclic	5					
Condensing Humidity Cyclic		8				
Dry Cold			2			
Dry Heat			3			
Resistance to soldering Reflow heat				1		

8. Test Result

Group	Test Item	N	Condition	Test Result			Requirement	Judgment
				Max	Min	Ave		
A	Examination of Product	5	Initial	No physical damage occurred			No abnormalities	Pass
	LLCR	5	Initial	19.75	14.51	16.99	<50mΩ	Pass
	Random Vibration	5	Final	No discontinuities of 1 microsecond or longer duration occurred			No abnormalities	Pass
	Mechanical Shock	5	Final	No discontinuities of 1 microsecond or longer duration occurred			No abnormalities	Pass
	LLCR	5	Final	22.98	15.84	17.93	<100mΩ	Pass
	Damp Heat Cyclic	5	Final	No physical damage occurred			No abnormalities	Pass
	LLCR	5	Final	18.81	14.78	16.21	<100mΩ	Pass
	Examination of Product	5	Final	No physical damage occurred			No abnormalities	Pass
B	Examination of Product	5	Initial	No physical damage occurred			No abnormalities	Pass
	LLCR	5	Initial	19.23	14.58	16.84	<50mΩ	Pass
	Insulation Resistance	5	Initial	8.66E+12	1.52E+12	3.58E+12	>100MΩ	Pass

	Dielectric Strength	5	Initial	No breakdown			No abnormalities	Pass
	Normal Force at 1.9mm to PWB	5	Initial	0.26	0.20	0.22	>0.2N	Pass
	Normal Force at Housing Surface	5	Initial	0.79	0.76	0.78	<1.0N	Pass
	Durability	5	Final	No physical damage occurred			No abnormalities	Pass
	Normal Force at 1.9mm to PWB	5	Final	0.24	0.20	0.21	>0.2N	Pass
	Normal Force at Housing Surface	5	Final	0.79	0.76	0.77	<1.0N	Pass
	Thermal Shock		Final	No physical damage occurred			No abnormalities	Pass
	Condensation Humidity Cyclic		Final	No physical damage occurred			No abnormalities	Pass
	LLCR	5	Final	19.66	15.36	17.42	<100mΩ	Pass
	Insulation Resistance	5	Final	7.90E+12	1.00E+12	3.03E+12	>100MΩ	Pass
	Dielectric Strength	5	Final	No breakdown			No abnormalities	Pass
	Examination of Product	5	Final	No physical damage occurred			No abnormalities	Pass
C	Examination of Product	5	Initial	No physical damage occurred			No abnormalities	Pass
	LLCR	5	Initial	23.85	15.03	17.62	<50mΩ	Pass
	Dry Cold	5	Final	No physical damage occurred			No abnormalities	Pass
	Heat Cold	5	Final	No physical damage occurred			No abnormalities	Pass
	LLCR	5	Final	22.64	11.49	16.30	<100mΩ	Pass
	Examination of Product	5	Initial	No physical damage occurred			No abnormalities	Pass
D	Examination of Product	5	Initial	No physical damage occurred			No abnormalities	Pass
	Resistance to Soldering Heat	5	Final	No physical damage occurred			No abnormalities	Pass
	Temperature Rise vs. Current	5	Final	1.2	0.8	1.0	<30°C	Pass
	Examination of Product	5	Final	No physical damage occurred			No abnormalities	Pass
E	Examination of Product	5	Initial	No physical damage occurred			No abnormalities	Pass
	Terminal Retention Force	5	Final	1.7	0.6	1.2	>0.5N	Pass
	Examination of Product	5	Final	No physical damage occurred			No abnormalities	Pass

F	Examination of Product	20	Initial	No physical damage occurred	No abnormalities	Pass
	Connector Peel Strength	20	Final	No physical damage occurred	No abnormalities	Pass
	Examination of Product	20	Final	No physical damage occurred	No abnormalities	Pass

END