

SAFETY PRECAUTIONS READ THIS FIRST! 2

1. INTRODUCTION 4

2. RECEIVING/INSPECTION 4

3. INSTALLATION/REMOVAL OF DIE ASSEMBLIES 4

 3.1. Installation of Die Assemblies 5

 3.2. Removal of Die Assemblies 6

4. USER INTERFACE INFORMATION 7

 4.1. Light Emitting Diode (LED) Indicators 7

 4.2. Pressure Sensor 7

5. OPERATION 8

 5.1. Battery Installation and Removal 8

 5.2. Crimping 8

6. PREVENTIVE MAINTENANCE 9

 6.1. Daily Maintenance 9

 6.2. Yearly Maintenance 9

7. SPARE PARTS 9

8. TROUBLESHOOTING 9

9. DECOMMISSIONING 9

10. RETURN 10

11. RoHS INFORMATION 10

12. REVISION SUMMARY 10

SAFETY PRECAUTIONS — IMPORTANT SAFETY INFORMATION



NOTE

Keep all decals clean and legible, and replace them when necessary.



**DANGER
ELECTRIC SHOCK HAZARD**

This tool is not insulated. When using this unit near energized electrical lines, use proper personal protective equipment.



Failure to observe this warning could result in severe injury or death.



**DANGER
SKIN INJECTION HAZARD**

Do not use hands to check for oil leaks. Highly pressurized oil will puncture the skin causing serious injury, gangrene, or death. If injured, seek medical help immediately to remove the oil.



**DANGER
FIRE HAZARD**

Do not use solvents or flammable liquids to clean the crimping tool. Solvents or flammable liquids could ignite and cause serious injury or property damage.



Failure to heed these warnings could result in severe injury from harmful fumes or burns from flying debris.



**DANGER
FIRE HAZARD**

Do not dispose of batteries in a fire. They will vent fumes and will explode. Instead, dispose of batteries in an environmentally responsible manner or send the battery back to TE.



DANGER

Inspect the tool and jaws/dies before each use. Replace any worn or damaged parts. A damaged or improperly assembled tool can break and strike nearby personnel.

Failure to observe this warning could result in severe injury or death.



CAUTION

— Do not place the tool in a vise. The crimping tool is designed for hand-held operation.

— Protect the crimping tool from rain and moisture. Water will damage the crimping tool and battery.

Failure to observe these precautions may result in injury or property damage.



CAUTION

— Do not allow anything to contact the battery terminals.

— Do not immerse the batteries in liquid. Liquid may create a short circuit and damage the battery. If the batteries are immersed, contact your service center for proper handling.

— Do not place the battery into a pocket, tool pouch, or tool box with conductive objects. Conductive objects may create a short circuit and damage the battery.

— Do not place a battery on moist ground or grass. Moisture may create a short circuit and damage the battery.

Failure to observe these precautions may result in injury or property damage.



CAUTION

— Do not store the battery at more than 60°C [140°F]. Damage to the battery can result.

— Do not use another manufacturer's charger.

— Do not attempt to open the battery. It contains no user-serviceable parts.

Failure to observe these precautions may result in injury or property damage.



CAUTION

— Do not perform any service or maintenance other than as described in this manual. Injury or damage to the tool may result.

Failure to observe these precautions may result in injury or property damage.

SAFETY PRECAUTIONS — AVOID INJURY

Safeguards are designed into this application equipment to protect operators and maintenance personnel from most hazards during equipment operation. However, certain safety precautions must be taken by the operator and repair personnel to avoid personal injury, as well as damage to the equipment. For best results, application equipment must be operated in a dry, dust-free environment. Do not operate equipment in a gaseous or hazardous environment.

Carefully observe the following safety precautions before and during operation of the equipment:

- ALWAYS wear appropriate ear protection.
- ALWAYS wear approved eye protection when operating powered equipment.
- ALWAYS keep guard(s) in place during normal operation.
- ALWAYS insert power plug into a properly grounded receptacle to avoid electrical shock.
- ALWAYS turn off the main power switch and disconnect electrical cord from the power source when performing maintenance on the equipment.
- NEVER wear loose clothing or jewelry that may catch in moving parts of the application equipment.
- NEVER insert hands into installed application equipment.
- NEVER alter, modify, or misuse the application equipment.

TOOLING ASSISTANCE CENTER

CALL TOLL FREE 1-800-722-1111 (CONTINENTAL UNITED STATES AND PUERTO RICO ONLY)

The **Tooling Assistance Center** offers a means of providing technical assistance when required. In addition, Field Service Specialists are available to provide assistance in the adjustment or repair of the application equipment when problems arise which your maintenance personnel are unable to correct.

INFORMATION REQUIRED WHEN CONTACTING THE TOOLING ASSISTANCE CENTER

When calling the Tooling Assistance Center regarding service to equipment, it is suggested that a person familiar with the device be present with a copy of the manual (and drawings) to receive instructions. Many difficulties can be avoided in this manner.

When calling the Tooling Assistance Center, be ready with the following information:

1. Customer name
2. Customer address
3. Person to contact (name, title, telephone number, and extension)
4. Person calling
5. Equipment number (and serial number if applicable)
6. Product part number (and serial number if applicable)
7. Urgency of request
8. Nature of problem
9. Description of inoperative component(s)
10. Additional information/comments that may be helpful

1. INTRODUCTION

Latch Head Battery Powered Crimp Tool Kit 2217330-[] consists of the Latch Head Battery Powered Crimp Tool (with the Latch Head Assembly installed), as well as two rechargeable battery cartridges (2217332-1) to power the tool. See Figure 1. Kits 2217330-1 and -3 include a 110V battery charger (2217331-1); Kit 2217330-2 includes a 220V battery charger (2217331-2). Kits 2217330-1 and -2 have a release switch to retract the ram. Kit 2217330-3 does not have a release switch. The Latch Head Battery Powered Crimp Tool is designed to accept interchangeable die assemblies for crimping various types of connectors.

When reading this manual, pay particular attention to DANGER, CAUTION, and NOTE statements.

**DANGER**

Denotes an imminent hazard that may result in moderate or severe injury.

**CAUTION**

Denotes a condition that may result in product or equipment damage.

**NOTE**

Highlights special or important information.

**NOTE**

Dimensions in this customer manual are in metric units [with U.S. customary units in brackets]. Figures are not drawn to scale.

2. RECEIVING/INSPECTION

Latch Head Battery Powered Crimp Tool Kit 2217330-[] is thoroughly inspected during and after assembly. Prior to packaging and shipping, a final series of tests and inspections is made to ensure proper functioning of the tool. The following inspection should be performed as a safeguard against potential problems generated in transit.

1. In a well-lighted area, carefully uncrate the tool and inspect each component as it is removed from the crate.
2. Thoroughly inspect each component for evidence of damage that may have occurred in transit. If any of the components are damaged, file a claim against the carrier and notify TE Connectivity immediately.
3. Keep this manual and all drawings and product samples with the tool for the benefit of operation and maintenance personnel.

The crimp tool should be inspected at regularly scheduled intervals, depending on care, degree of operator skill, the type and size of product being crimped, and environmental conditions. At a minimum, the tool should be inspected after every 40 hours of use.

3. INSTALLATION/REMOVAL OF DIE ASSEMBLIES

**CAUTION**

Do not operate the tool without the Latch Head Installed. Damage to the ram or seals can result.

**CAUTION**

Do not operate the tool without the die assemblies. Damage to the crimp head can result.

Latch Head Battery Powered Crimp Tool 2217330-[] comes with the crimp head already installed on the battery-powered hand tool. The only installation required is the installation of the die assemblies.

**DANGER**

To avoid personal injury, be sure to exercise extreme caution when handling the crimp tool. Avoid accidentally depressing the trigger control when installing or removing crimp dies.

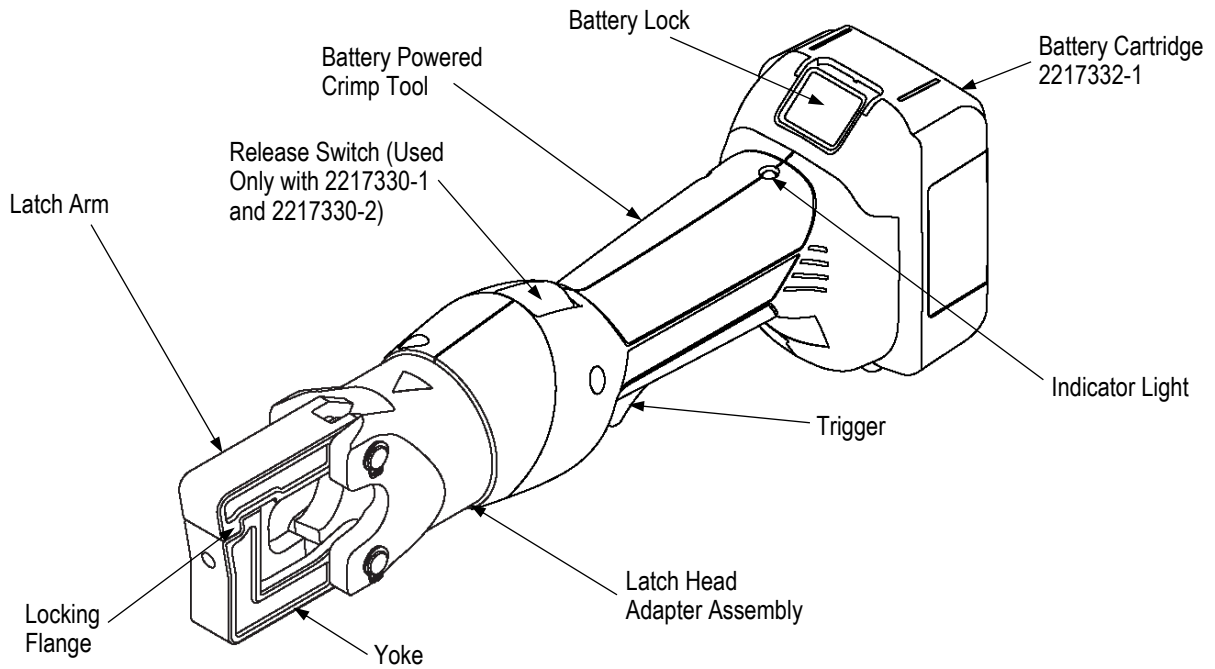

CRIMPING TOOL (With Battery Installed)	
Length	336.5 mm [13.25 Inches]
Width	72.9 mm [2.87 Inches]
Depth	114 mm [4.5 Inches]
Mass Weight (with Battery)	1.88 kg [4.2 lbs]
Sound Level	70 dBA at 1 Meter
Vibration	<2.5 m/s ²
Hydraulic Oil	Shell Tellus T 15 or RIVOLTA S.B.H. 11
CRIMPING CAPACITIES	
Maximum Crimping Force	43.3 kN [9734 pounds]
Average Crimping Time	2-4 Seconds
Average Crimps Per Charge	85-170 (Approx.)
BATTERY	
Charging Voltage	18 V
Charging Time	15 Min. – 1.3 AH/22 Min. – 3.0 AH

Figure 1

3.1. Installation of Die Assemblies

Refer to Figure 2.



CAUTION

These instructions are specific to the use of TE Die Assemblies. Be sure to use ONLY TE Die Assemblies.

1. With the battery installed, extend the ram until the ram setscrew is visible.
2. Remove the battery from the tool.

Shell and RIVOLTA are trademarks of their respective owners.

3. Loosen the setscrew in the ram.
4. Insert the shank of the moving die into the ram, and tighten the setscrew.
5. Pivot the latch arm away from the yoke to open up the crimp head.
6. Loosen the setscrew in the yoke.
7. Insert the shank of the stationary die into the yoke, and tighten the setscrew.



CAUTION

To avoid damage to the dies, be sure that the moving and stationary dies are properly oriented.

8. Replace the battery and activate the power unit to allow the ram to return to the “down” position.
9. Pivot the yoke toward the latch arm until the locking flange secures the latch arm to the yoke.



CAUTION

Always make sure the yoke and latch arm are secured by the locking flange before cycling the tool to crimp the product.

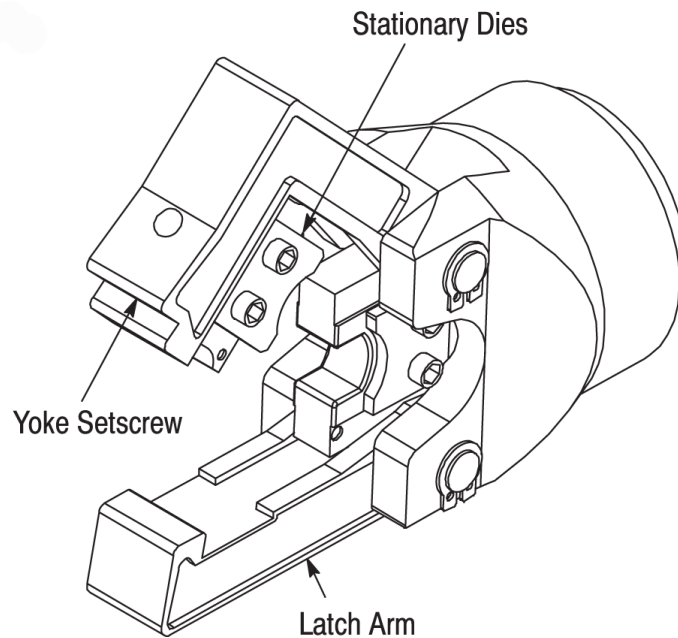

Figure 2

3.2. Removal of Die Assemblies

Refer to Figure 3.



DANGER

To avoid personal injury, do not accidentally depress the trigger while removing the dies.

1. Pivot the latch arm away from the yoke to open the head.
2. Extend the ram until the ram setscrew is visible.
3. Remove the battery from the tool.
4. Loosen the setscrew in the yoke, and remove the stationary die.
5. Loosen the setscrew in the ram, and remove the moving die.

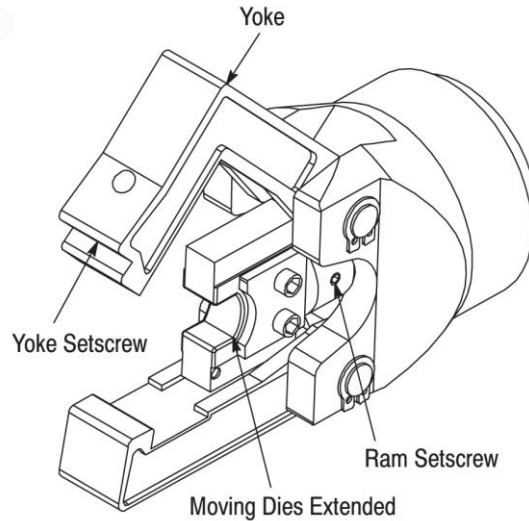

Figure 3

4. USER INTERFACE INFORMATION

(Pre-Operation Testing)

4.1. Light Emitting Diode (LED) Indicators

A. White LED Work Light

This LED automatically turns on when the trigger is pulled. The indicator remains lit for ten seconds *after* the trigger is released.

B. Red LED Indicator

The tool is equipped with a special circuit board incorporating several important features. These features inform the user of the current status of the unit. The red LED signals in the following cases:

WHAT HAPPENS	WHAT IT MEANS
Red LED flashes for two seconds.	The battery has been inserted in the tool.
Red LED is lit constantly for 20 seconds at the end of the cycle.	Battery charge is below 17 volts at the beginning of the cycle.
Tool will not start. Red LED light remains lit for 20 seconds after trigger is released	Battery charge is below 16 volts at the beginning of the cycle.
Tool will stop. Red LED light remains lit for 20 seconds after the trigger is released.	Battery voltage drops below 13 volts during the cycle.
Tool will stop. The LED will flash for 20 seconds after the trigger is released.	Motor current exceeds 20A during the cycle.
	Circuit has become hot.

Figure 4

4.2. Pressure Sensor

The tool is equipped with a pressure sensor that alerts the user of an incomplete crimp.

- If the tool is manually retracted before completion of a crimp, the red LED will flash for two seconds and an audible alarm will sound for two seconds.
- If the tool is unable to reach the required crimp force, the red LED will flash for two seconds and an audible alarm will sound until after the trigger is released.



NOTE

The tool has an on-board memory of previous crimp cycles and the cycle count. This information can be accessed and downloaded onto a computer using USB Adapter Module 2217896-1.

5. OPERATION

5.1. Battery Installation and Removal

Refer to Figure 1.

**NOTE**

The Batteries Directive 2006/66/EC introduces new requirements from September 2008 on removability of batteries from waste equipment in EU Member States. To comply with this Directive, this device is designed to allow the rechargeable battery pack to be easily removed by the end-user when it needs to be replaced.

To install the battery, slide the battery into the bottom of the crimp tool until it can go no further. There will be an audible “click” of the battery lock to indicate that the battery has been properly installed.

To remove the battery, disengage the battery lock by applying pressure on the lock toward the bottom of the tool and slide the battery away from the tool.

**DANGER**

Always dispose of the old battery pack in an environmentally-responsible way, in accordance with local waste regulations. Where possible, please recycle the battery cartridge. Contact your local authority for details of battery recycling locations in your area.

5.2. Crimping

The following procedure provides only general information concerning crimping. Refer to the instructions packaged with the dies for detailed information, including wire stripping dimensions and instructions for positioning terminals and splices in the die assemblies.

Operation of Latch Head Battery Powered Crimp Tool 2217330-[] consists of:

**DANGER**

Avoid personal injury. When operating tool or power unit, exercise caution while holding terminals or wire near the crimping area.

1. Strip the wire to the dimensions provided for the terminals in TE Instruction Sheets [408-10050](#) (SOLISTRAND* Terminals and Splices); or [408-10051](#) (TERMINYL*, AMPOWER*, PLASTI-GRIP* Terminals and Splices). Do not nick or cut the wire strands.
2. Select the proper color-coded terminal for the wire size. The wire size stamped on the terminal tongue and on the crimping die must match the wire size selected.
3. Insert stripped wire fully into the terminal wire barrel.

**CAUTION**

Do NOT turn or twist the wire or terminal during insertion.

4. Pivot the latch arm away from the yoke to open the head.
5. Place the terminal in the stationary die.
6. Holding the terminal in place, pivot the yoke and latch arm toward each other until the locking flange secures the latch arm to the yoke.

**CAUTION**

Always make sure the yoke and latch arm are secured by the locking flange before cycling the tool to crimp the product.

7. Holding the wire in place, activate the tool to complete the crimp.
8. When the crimp is completed, pivot the latch arm away from the yoke to open the head and remove the terminal.

**NOTE**

If the terminal sticks in the die after crimping, apply a rocking action to the terminal to remove it from the die. Wipe light oil on the dies to prevent sticking, or use spray dry lubricant.

**NOTE**

If it is necessary to retract the ram before a crimping cycle is completed, push the release switch. Pushing the release switch will result in the complete retraction of the ram. Only kits 2217330-1 and -2 have a release switch.



CAUTION

This tool is not designed for continuous operation. After 100 cycles, allow the crimp tool to cool for 15 minutes.

9. Inspect the crimp according to the crimping procedures for the terminals provided in TE Instruction Sheets [408-10050](#) (SOLISTRAND Terminals and Splices); or [408-10051](#) (TERMINYL, AMPOWER, PLASTI-GRIP Terminals and Splices).

6. PREVENTIVE MAINTENANCE

6.1. Daily Maintenance

Perform the following maintenance on a daily basis:

1. Inspect the dies for wear or damage such as cracks, gouges, or chips.
2. Inspect the tool for damage or leaks. If damage is detected, return the tool to TE for repair.
3. Clean the tool, removing accumulations of dirt and grease on the head, particularly in areas where dies are installed and terminals are crimped. Wipe the entire tool frequently with a clean, lint-free cloth.

6.2. Yearly Maintenance

Once per year, or every 10,000 cycles (whichever comes first), the Latch Head Battery Powered Crimp Tool should be returned to TE for inspection.

7. SPARE PARTS

- Battery: 2217332-1
- Charger: 2217331-1 (120 V, US), 2217331-2 (220 V, EU)

8. TROUBLESHOOTING

See Figure 5.

Prior to beginning troubleshooting procedures, be sure the battery is operational.

1. Be sure that the battery is charged. Recheck the battery after several minutes to ensure that the battery is holding its charge.
2. Use a nonflammable contact cleaner or pencil eraser to clean the electrical contacts on the battery and crimp tool.
3. Reinstall the battery and check the crimp tool again.

PROBLEM	PROBABLE CAUSE	REMEDY
Tool is inoperative.	Dirt, contaminants, etc., in ram area of tool	Clean the tool.
	Crimp tool battery contacts damaged.	Reform the contacts
	Tool components worn or damaged.	Return tool to TE.
Dies stop during operation.	Oil level is low.	Return tool to TE.
	Air is in the hydraulic system.	Pull the trigger and hold the retract button simultaneously. Hold for about 10 seconds.
Crimp tool loses oil.	There is damage to the internal seal.	Return tool to TE.

Figure 5

9. DECOMMISSIONING

In compliance with the regulations in force in the country where the tool is used, the user must make sure that waste produced during operation is correctly disposed. Disposal of lubricants and parts removed must be carried out in compliance with the standards in force in the country where the tool is used.

10. RETURN

Order replacement parts through your TE representative, or call 1.800.526.5142; or send a facsimile of your purchase order to 1.717.986.7605; or write to:

CUSTOMER SERVICE (038-035)
TE CONNECTIVITY CORPORATION
PO BOX 3608
HARRISBURG PA 17105-3608

For customer repair service, call 1.800.526.5136.

11. RoHS INFORMATION

Information on the presence and location of any substances subject to RoHS (Restriction on Hazardous Substances) can be found at the following website:

<http://www.tycoelectronics.com/customersupport/rohssupportcenter/>

Click on “Check Product Compliance and Get Statements of Compliance (SoC)” and then click on “Check Product Compliance Search Tool.”

12. REVISION SUMMARY

- Updated corporate logo and name
- Figure 1: change maximum crimping force from 35 kN [4 tons] to 43.3 kN [9734 pounds]