

**AMP-HDI* CONNECTOR
JACKSCREW HARDWARE KITS,
GUIDE PINS, AND GUIDE PIN KITS**

REDUCED FOR PACKAGING

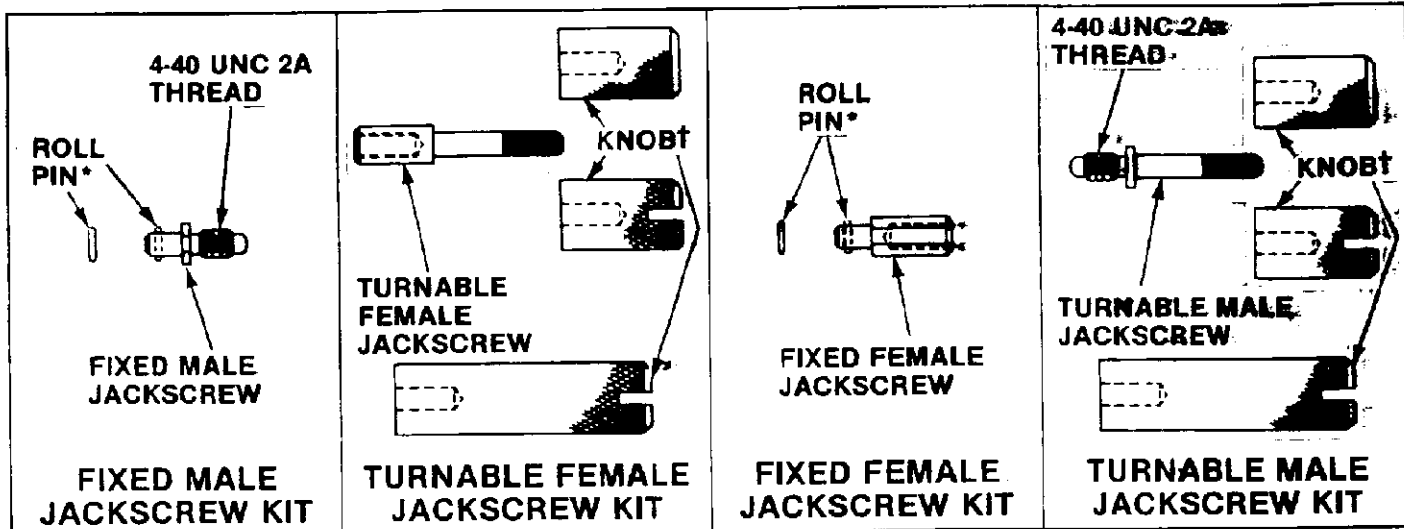

* TWO OPTIONS: ONE LONGER THAN THE OTHER

† THREE OPTIONS: ONE AS SHOWN, ANOTHER AS SHOWN WITH SCREWDRIVER SLOT, AND THE LAST LONGER THAN SECOND BUT ALSO WITH SCREWDRIVER SLOT

| KIT NO. | TYPE | STYLE | USED IN RECEPTACLE CONN PART NO. | MATING PIN CONN PART NO. | MATING KIT | | |
|----------|-------|--------|----------------------------------|--|----------------------------------|----------|--------|
| | | | | | PART NO. | TYPE | STYLE |
| 532804-5 | Fixed | Male | 532428 532825 (Two-Row) | 532429 533090 533060 532446 532430 533091 | | | |
| 532804-1 | Fixed | Male | 532431 533268 (Three-Row) | 532432 533092 533061 532447 532433 533093 | 532804-2 532804-3 532804-4 | Turnable | Female |
| | | | 532918 533514 (Three-Row) | 532919 533434 533296 533294 532931 533513 | | | |
| | | | 532838 533425 (Three-Row) | 532836 533511 533426 533094 532839 533512 | | | |
| | | | 532434 532903 (Four-Row) | 532435 533254 532818 532448 532436 533270 | | | |
| | | | 532920 533443 (Four-Row) | 532921 533446 533445 533083 532933 533447 | | | |
| | | | 532840 533449 (Four-Row) | 532837 533404 533056 532944 532841 533448 | | | |
| 532805-5 | Fixed | Female | 532428 532825 (Two-Row) | 532429 533090 533060 532446 532430 533091 | | | |
| 532805-1 | Fixed | Female | 532431 533268 (Three-Row) | 532432 533092 533061 532447 532433 533093 | 532805-2 532805-3 532805-4 | Turnable | Male |
| | | | 532918 533514 (Three-Row) | 532919 533434 533296 533294 532931 533513 | | | |
| | | | 532838 533425 (Three-Row) | 532836 533511 533426 533094 532839 533512 | | | |
| | | | 532434 532903 (Four-Row) | 532435 533254 532818 532448 532436 533270 | | | |
| | | | 532920 533443 (Four-Row) | 532921 533446 533445 533083 532933 533447 | | | |
| | | | 532840 533449 (Four-Row) | 532837 533404 533056 532944 532841 533448 | | | |

Fig. 1

1. INTRODUCTION

This instruction sheet (IS) covers the selection and assembly of AMP-HDI Connector Jackscrew Hardware Kits, Guide Pins, and Guide Pin Kits. The jack-screw hardware kits are listed by part number in Figure 1; the guide pins and guide pin kits are listed by part number in Figure 6.

Read these instructions thoroughly before starting to assemble the parts.

NOTE

All dimensions shown on this instruction sheet are in inches.

Copyright 1985 by AMP Incorporated, Harrisburg, PA. All Inter-
national, Registered, and Unregistered trademarks covered by U.S.
Patent, Design, and Copyright Laws are hereby acknowledged.

* Trademark of AMP Incorporated.

2. JACKSCREW HARDWARE KITS

The jackscrew kits consist of a variety of hardware that is designed for positive and quick mating and unmating of printed circuit (pc) board-mounted connectors. Two types of jackscrews are available—fixed and turnable. Each type is supplied in two styles—male and female. *Fixed* male and *fixed* female jackscrew kits are used with receptacle connectors only. *Turnable* male and *turnable* female jackscrew kits are used only with pin connectors. See Figure 1. The fixed male jackscrew kits (532804-1 and 532804-5) each consist of a fixed male jackscrew and a roll pin. One kit is supplied with a short roll pin and is designed for the two-row connectors. The other kit is available with a longer roll pin and is designed for three- and four-row connectors. Once installed, the fixed hardware remains stationary in the receptacle connector keying hole and does not rotate.

Hardware that is compatible with the fixed male jackscrew kits includes three options of turnable female jackscrew kits (532804-2, 532804-3, and 532804-4). Each option consists of a turnable female jackscrew and one of three knobs. One is a short knob without a screwdriver slot; another includes a short knob with a screwdriver slot; and the last is a longer knob with a screwdriver slot. Once installed, turnable hardware freely rotates in the pin connector keying hole.

Fixed female jackscrew kits and turnable male jackscrew kits are also supplied. The fixed female jackscrew kits (532805-1 and 532805-5) are compatible with turnable male jackscrew kits 532805-2, 532805-3, and 532805-4. See Figure 1.

3. JACKSCREW HARDWARE PROCEDURE

The use of different styles of jackscrews can prevent connectors from mismatching. Figures 2 and 3 illustrate how different styles of jackscrew hardware—male and female—can be installed on both the pin and receptacle connectors. Note that two of the same style can be used in the same connector.

NOTE

Opposite-style jackscrews must be used in mating connectors (male jackscrews to female jackscrews).

The steps which follow are recommended to assemble jackscrew hardware kits:

1. Select two of the *fixed* jackscrew kits from Figure 1; the kits selected will be assembled on each end of the receptacle connector.
2. Assemble each kit by first inserting the jackscrew tip into the front—or mating face—of the receptacle connector as shown in Figure 2, making certain that the chamfered hole in the shank is visible. If using three- or four-row connectors, the chamfered hole will be visible from the sides. If using two-row connectors, the hole will be visible from the top.
3. Using needle-nose pliers, install the roll pin into the shank of the jackscrew tip. See Figure 2.

NOTE

Fixed jackscrew kits should be assembled to the receptacle connector PRIOR to mounting the connector onto the printed circuit board.

4. Select two *turnable* jackscrew kits from Figure 1 for each pin connector. Once

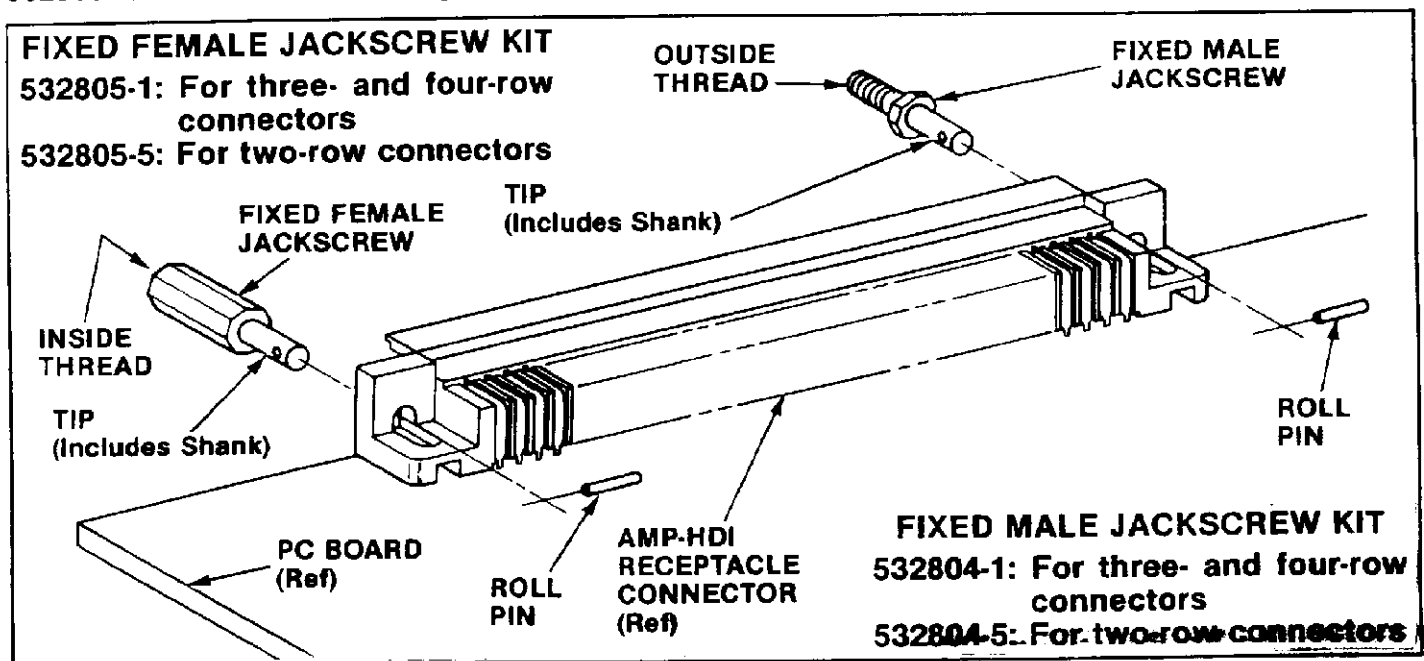

Fig. 2

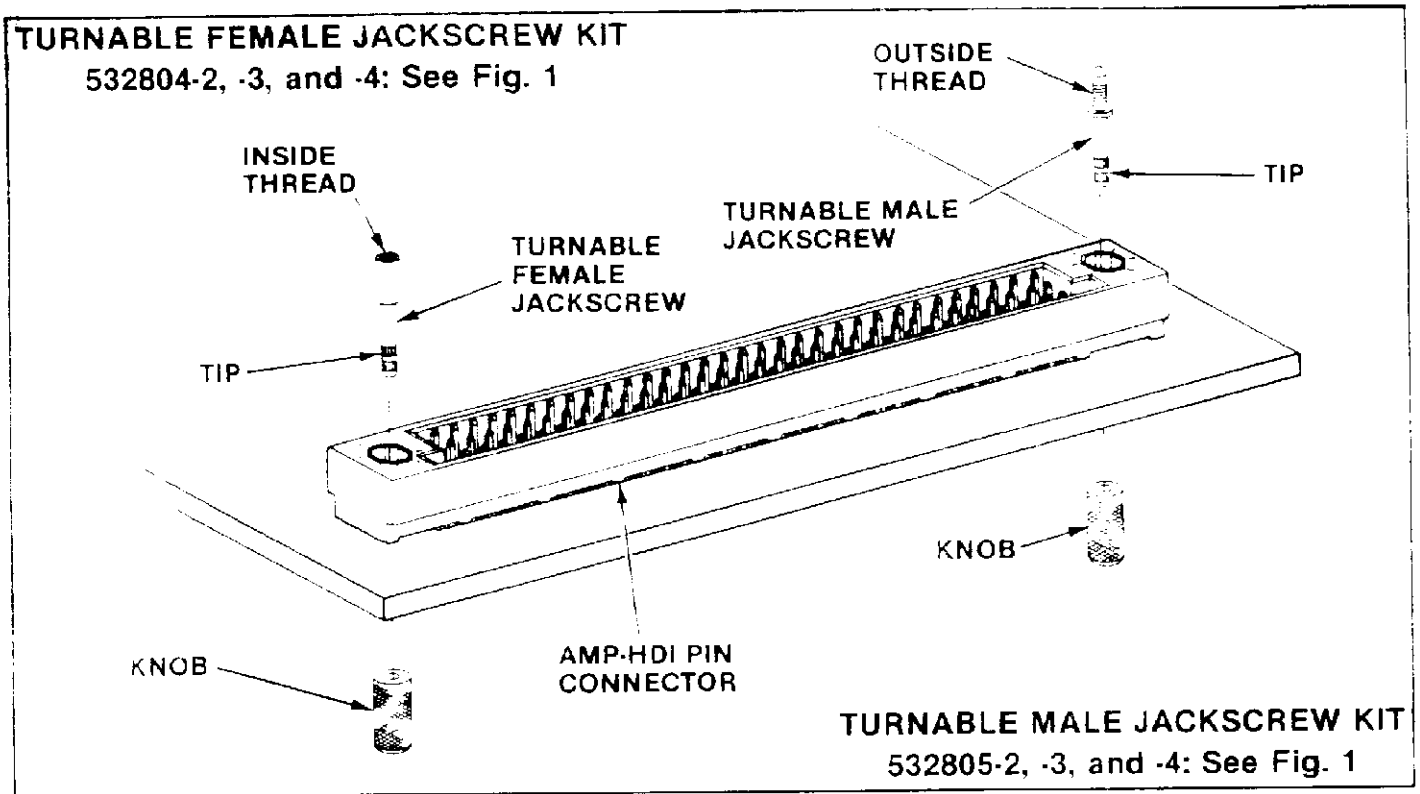

Fig. 3

Installed, these jackscrew kits will mate with those assembled on the receptacle connector.

5. Assemble each turnable kit by first inserting the jackscrew tip into the top of the pin connector as shown in Figure 3.

6. Next, position the shank of the female jackscrew tip over the knob as shown in Figure 4; it is recommended that a plate with a .265-in.-diameter hole be used to nest the knob

during the jackscrew assembly. Seat the jackscrew into the knob by using an arbor tool (Figure 4).

7. To assemble a turnable male jackscrew to a knob, first screw a turnable female jackscrew onto the male jackscrew. Use the same plate mentioned in Step 6 to nest the knob. Next, line up the components as shown in Figure 5 and seat the jackscrew into the knob by using an arbor tool.

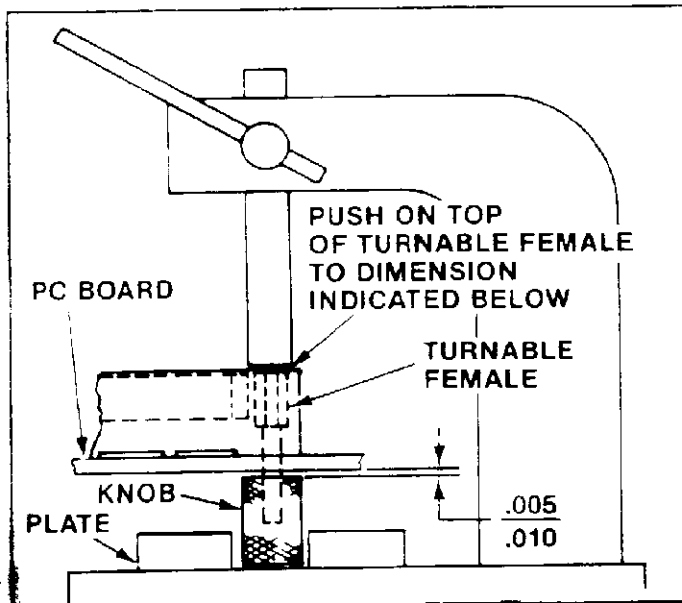

Fig. 4

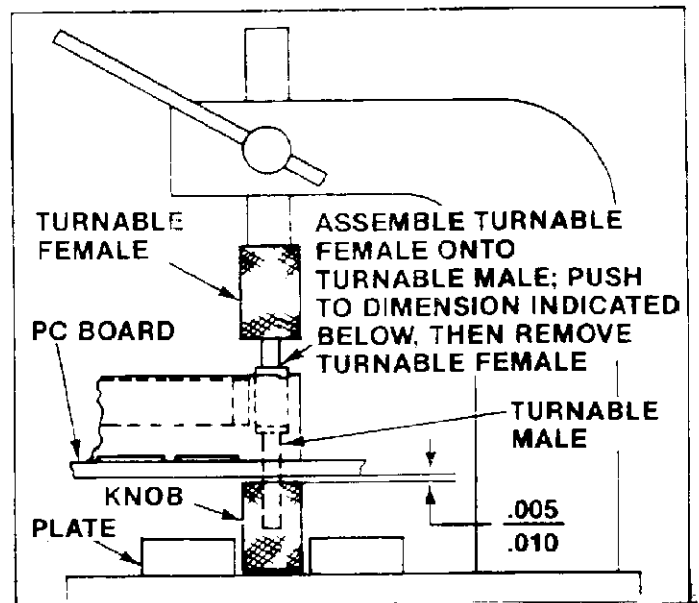
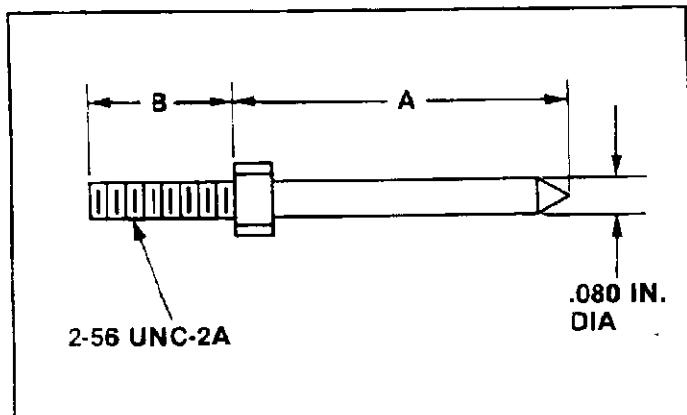

Fig. 5



connector assemblies, making sure that the matching hardware is compatible with the hardware installed on the mating counterpart.

4. GUIDE PINS AND GUIDE PIN KITS

Guide pins are designed to facilitate the mating of large-size AMP-HDI pin and receptacle connectors. By using the guide pins, connectors with misalignment of as much as .080 in. in diameter can be mated successfully. Guide pins can be purchased separately or in kits. A kit consists of one guide pin, one nut, and one washer.

Part numbers of pins and kits are listed in Figure 6.

5. GUIDE PIN ASSEMBLY PROCEDURE

Guide pins are assembled to AMP-HDI pin connectors after the connectors have been secured to the pc board. See Figure 7. Selection of the correct pin or guide pin kit will depend on the pc board thickness. Refer to Figure 6.

| GUIDE PIN PART NO. | GUIDE PIN KIT PART NO. | DIMENSIONS | |
|--------------------|------------------------|------------|-------|
| | | A | B |
| 532807-1 | 532808-1 | 0.650 | 0.475 |
| 532807-2 | 532808-2 | 0.650 | 0.562 |
| 532807-3 | 532808-3 | 0.650 | 0.750 |

Fig. 6

3. When assured that the jackscrew hardware has been properly installed, mate the two

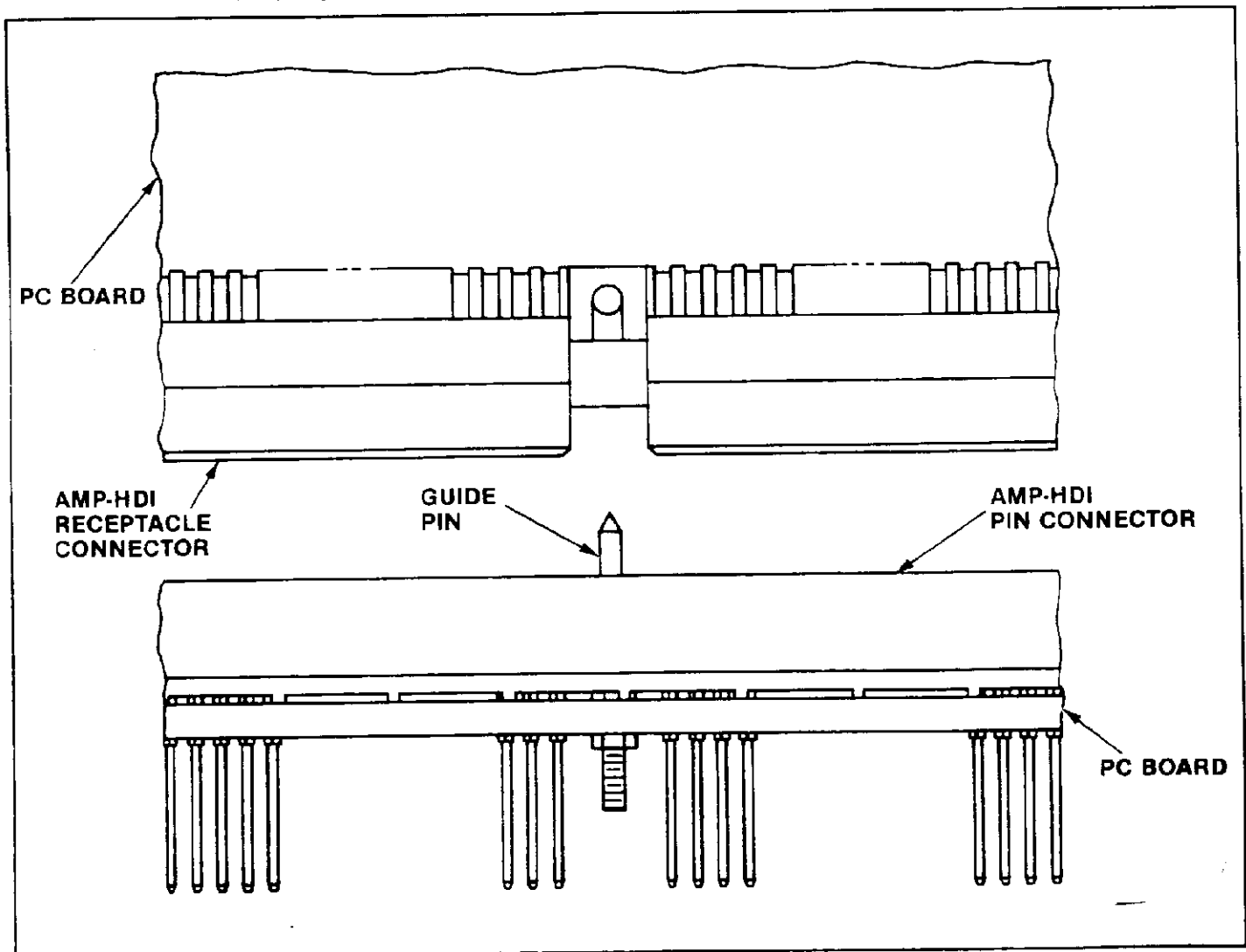

Fig: 7