

# HVT-Z Series Terminations

15 - 35kV Class High Voltage Terminations for Jacketed Concentric Neutral and Concentric Neutral Power Cables

**ENERGY DIVISION**

### Suggested Installation Equipment (not supplied with kit)

- Cable preparation tools
- Tyco Electronics P63 cable preparation kit or cable manufacturer approved solvent
- Clean, lint-free cloths
- Non-conducting abrasive cloth, 120 grit or finer
- Electrician's tape
- Connector(s) and installation tools
- Tyco Electronics recommended torch

### Safety Instructions

**Warning:** When installing electrical power system accessories, failure to follow applicable personal safety requirements and written installation instructions could result in fire or explosion and serious or fatal injuries.

To avoid risk of accidental fire or explosion when using gas torches, always check all connections for leaks before igniting the torch and follow the torch manufacturer's safety instructions.

To minimize any effect of fumes produced during installation, always provide good ventilation of confined work spaces.

*As Tyco Electronics has no control over field conditions which influence product installation, it is understood that the user must take this into account and apply his own experience and expertise when installing product.*

### Kit Contents

All items are listed per phase. At a minimum, the following items should be included in this kit:

- 1 Red, non-tracking tube
- 2 Red mastic strips
- 1 Yellow, angle-cut mastic strip for 15kV
- 1 Black, angle-cut mastic for 25/35kV
- 1 Set of Installation Instructions
- 1 Short, red shim tube (25/35 kV only)
- \* Red, heat-shrinkable skirts

\* 1 skirt for 15 kV, 4 for 25/35 kV for outdoor kits only.

### Recommended Tyco Electronics Torches

Install heat-shrinkable cable accessories with a "clean burning" torch, i.e., a propane torch that does not deposit conductive contaminants on the product.

Clean burning torches include the Tyco Electronics FH-2629, FH-2649 (uses refillable propane cylinders) and FH-2618A (uses disposable cylinder).

### Adjusting the Torch

Adjust regulator and torch as required to provide an overall 12- inch bushy flame. The FH-2629 will be all blue, the other torches will have a 3- to 4-inch yellow tip. Use the yellow tip for shrinking.

### Regulator Pressure

FH-2618A	Full pressure
FH-2649	25 psig
FH-2629	15 psig

### General Shrinking Instructions

- Apply outer 3- to 4-inch tip of the flame to heat-shrinkable material with a rapid brushing motion.
- Keep flame moving to avoid scorching.
- Unless otherwise instructed, start shrinking tube at center, working flame around all sides of the tube to apply uniform heat.

To determine if a tube has completely recovered, look for the following, especially on the back and underside of the tube:

1. Uniform wall thickness.
2. Conformance to substrate.
3. No flat spots or chill marks.
4. Visible sealant flow if the tube is coated.

*Note: When installing multiple tubes, make sure that the surface of the last tube is still warm before positioning and shrinking the next tube. If installed tube has cooled, re-heat the entire surface.*

## 1. Product Selection

Check kit selection with cable diameter dimensions in Table 1.

**Note:** Table is for 100% and 133% insulated Poly cable at 15kV and for 100% insulated cable at 25kV and 35kV. Check actual cable dimensions against diameters listed.

**Table 1**

Indoor Kit	Outdoor Kit	Conductor Size		Min/Max Insulation	Max. Jacket
<b>15 kV</b>		<b>0.175" Insulation</b>	<b>0.220" Insulation</b>		
		<b>100%</b>	<b>133%</b>		
HVT-Z-151-J	HVT-Z-151-SJ	#2 - #1 AWG		0.60 - 0.95"	1.05"
HVT-Z-152-J	JVT-Z-152-SJ	#2/0 - 250 kcmil	#2 - #4/0 AWG	0.80 - 1.05"	1.45"
HVT-Z-153-J	HVT-Z-153-SJ	350 - 500 kcmil	250 - 500 kcmil	1.05 - 1.40"	1.90"
HVT-Z-154-J	HVT-Z-154-SJ	750 - 1000 kcmil	750 - 1000 kcmil	1.25 - 2.00"	2.50"
<b>25 / 35 kV</b>		<b>25 kV 100%</b>	<b>35 kV 100%</b>		
		<b>0.260" Insulation</b>	<b>0.345" Insulation</b>		
HVT-Z-252/352-J	HVT-Z-252/352-SJ	#1 - #3/0 AWG		0.80 - 1.05"	1.45"
HVT-Z-253/353-J	HVT-Z-253/353-SJ	#4/0 - 500 kcmil	#1/0 - #4/0 AWG	1.05 - 1.40"	1.90"
HVT-Z-254/354-J	HVT-Z-254/354-SJ	750 - 1000 kcmil	250 - 1000 kcmil	1.25 - 2.00"	2.50"

## 2. Prepare Cables

Choose the cable type (Choice 1 or 2) and follow the directions given.

*Note: Jacket cutback is based upon a max. barrel length of 3-3/4". If the lug barrel is longer, the additional length must be added to jacket cutback to maintain proper termination stress control.*

**Figure at right: Insulation cutback (Z)**

**NOTE:** \*If no lug is used, Z = 2" (50mm)

*Z<sub>max</sub> = 4-1/4" (110mm) unless jacket cutback has been lengthened.*

**Table 2**

Voltage Class	Unjacketed Concentric Neutral Wire Whipback A	Jacketed Concentric Neutral Jacket Cutback B
	15kV	11-1/2" (290mm)
25/35kV	19.0" (480mm)	17.0" (430mm)

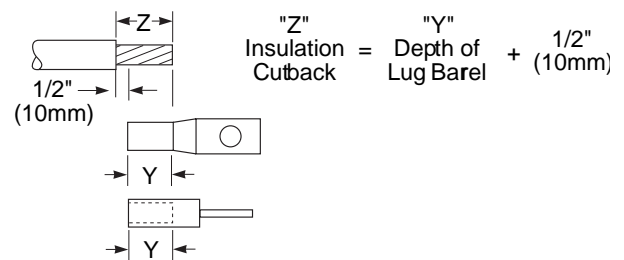

### CHOICE 1

#### Unjacketed Concentric Neutral Cable

Refer to Figure 1 and Table 2 to prepare the cables as shown for the proper voltage class. Place a wire binder at Dimension A and pull back the neutral wires.

**Go to Step 3.**

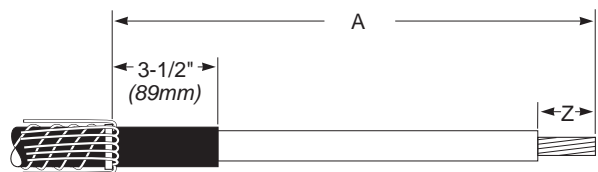

## CHOICE 2

### Jacketed Concentric Neutral Cable

Refer to Figure 1 and Table 2 to prepare the cables as shown for the proper voltage class.

Go to Step 3.

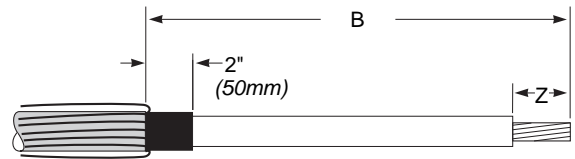

480

### 3. If Lug Is To Be Used; Install Lug

If no lug is used, go to Step 5.

After installation, clean and deburr lug.

**Note:** If the step between the lug barrel and the insulation is greater than  $1/8"$  (3mm), taper (chamfer) the insulation to meet the lug barrel. Conventional pencilling is not required.

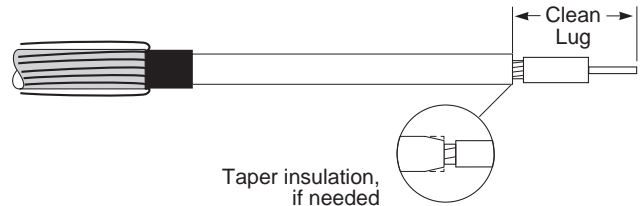

483

### 4. 25/35kV Termination with Lug

If 15kV, go to Step 5.

Apply red sealant on lug barrel.

Using light tension, wrap two layers of red sealant around the lug barrel.

Install shim.

Place the shim tube over the red sealant butted against the insulation and shrink into place. Apply heat with a smooth, brushing motion.

**Note:** If the shim does not fit over the lug barrel, it is not necessary to install the shim.

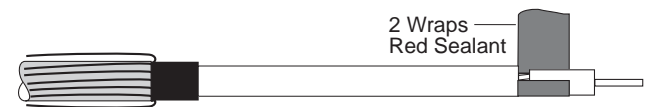

484

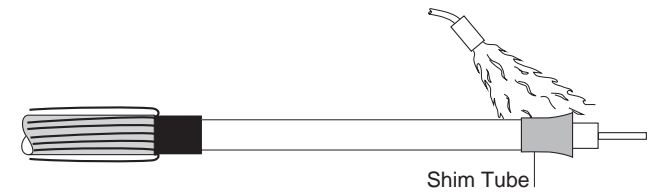

485

### 5. Abrade Insulation; Clean Cable

Abrade the insulation, if necessary, to remove imbedded semi-con. Using an oil-free solvent, clean the cable as shown.

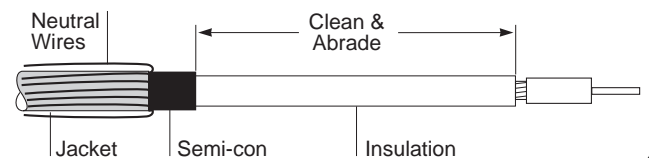

482

## 6. Apply Stress Relief Material (SRM) at Semi-con Cutback

### a. 15kV Terminations

Remove backings from the *short angle-cut* piece of SRM. Place tip of SRM at semi-con cutback and stretch to approximately 1/2 its original width. Tightly wrap 3 to 4 layers to fill semi-con step. Overlap semi-con and insulation as shown. Taper SRM down to meet insulation.

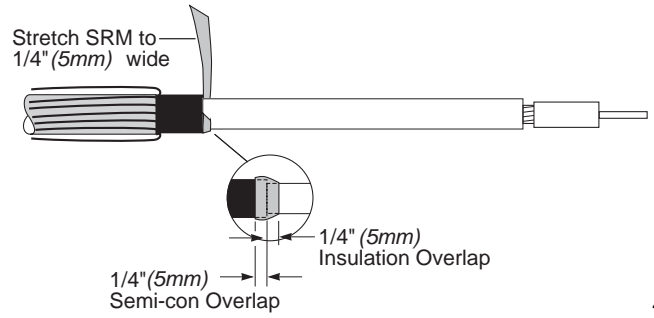

### b. 25/35kV Terminations

Remove the backings from the *black angle-cut* piece of SRM. Stretching the SRM slightly, wrap the SRM centrally around the semi-con cutback, extending 1/2" (12mm) onto the semi-con 1/2" (12mm) onto the insulation.

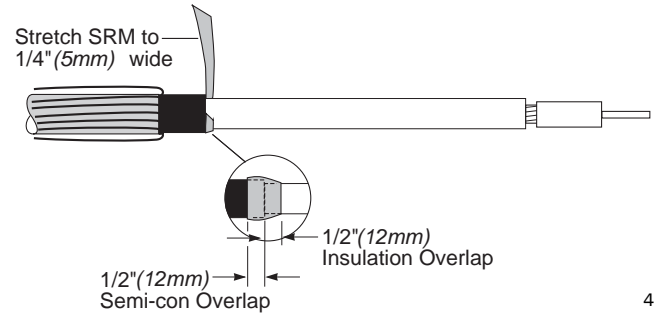

## 7. Complete Termination

Choose the cable type (Choice 1 or 2) and follow the directions given.

### CHOICE 1

#### Jacketed Concentric Neutral Cable

Steps 8-16 apply to Jacketed Concentric Neutral Cable Only.

Go to Step 8.

### CHOICE 2

#### Unjacketed Concentric Neutral Cable

Steps 17-24 apply to Unjacketed Concentric Neutral Cable Only.

Go to Step 17.

## CHOICE 1

### Jacketed Concentric Neutral Cable

#### 8. Apply Red Sealant

##### a. With Lug (or lug and shim)

Using light tension, wrap red sealant on lug barrel (or over shim). Build up lug diameter to cable insulation and overlap insulation by 1/2" (10mm).

##### b. Without Lug

Wrap two layers of red sealant onto the cable insulation as shown.

**Note:** If strands are exposed, sealant will not prevent water ingress between the strands.

#### a. With Lug (or lug & shim)

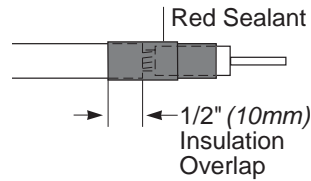

#### b. Without Lug

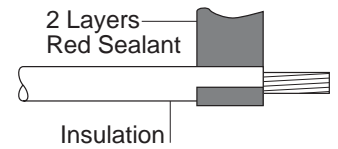

#### 9. Clean Cable; Apply Red Sealant Under Neutral Wires

Lift neutral wires away from the cable jacket. Using an oil-free solvent, clean the jacket for 2-1/2" (60mm) below the jacket cutback point.

Remove the backing from the red sealant. Using light tension, wrap two layers of red sealant onto the jacket under the neutral wires.

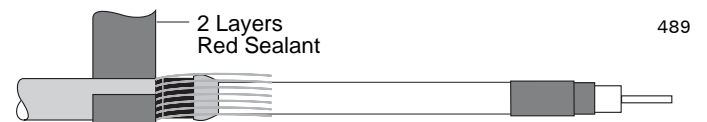
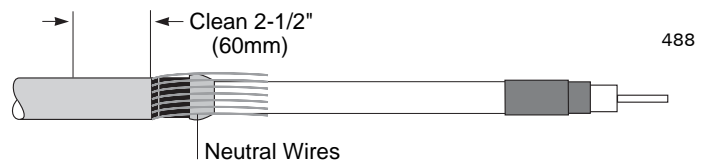

#### 10. Apply Red Sealant Over Neutral Wires

Lay the neutral wires evenly back over the jacket and press them into the red sealant. Using light tension, wrap two more layers of red sealant over the neutral wires and first two layers of sealant.

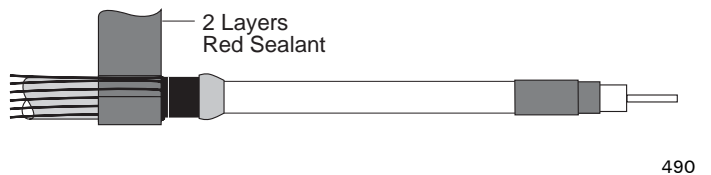

#### 11. Position the HV Tube

The bottom end of the tubing should be level with the red sealant on the cable jacket.



#### 12. Shrinking HV Tube

Shrink the tubing down starting at the semi-con cutback. Heat the area well but avoid scorching the surface. Continue shrinking towards the cable lug. Finally shrink down the bottom end of the tubing. The numbers in the drawing indicate the shrink sequence.

**Note:** After installation the termination must be post heated as well as the palm of the cable lug until a bead of sealant (green) appears around the top of the tubing. Allow the termination to cool before applying any mechanical strain.

**Note:** Due to the lubricating effect of the inner surface coating, there will be some longitudinal shrinkage of the tube.

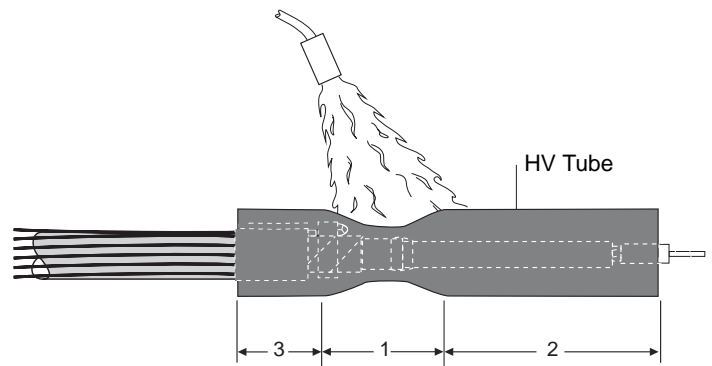

### 13. Trim HV Tube

**Note:** Allow termination to cool enough to touch before proceeding.

Trim excess tubing from the lug area as shown.

Twist neutral wires to make a ground lead.

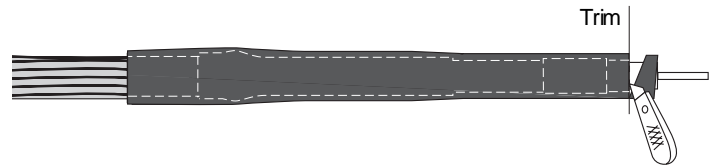

496

### 14. Inspect Installation

Inspect installation. Reheat any flat spots or wrinkles.

**Indoor termination for Jacketed Concentric Neutral cable is complete.**



510

### 15. Outdoor Terminations Only.

Position the skirt as shown and shrink it in place. Hold the edge of the skirt lightly with pliers. Brush flame tip around outside of skirt collar. Only the collar will shrink.

**This completes the 15kV termination. Additional skirts are required for the 25/35 kV termination.**

#### Standard Termination

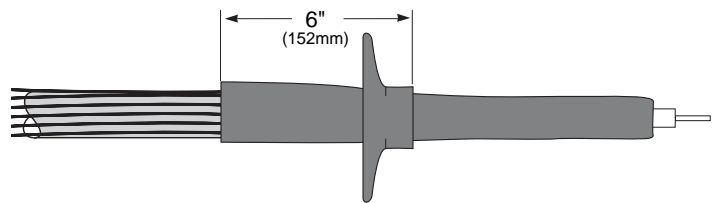

#### Top-Feed Termination

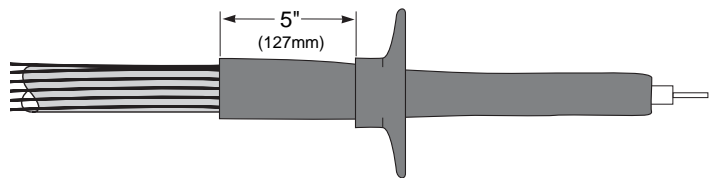

### 16. Position Remaining Skirts and Shrink in Place.

The 25/35kV kits have four skirts. Position the remaining skirts (facing the same direction as the first) as required for the voltage class and shrink them in place. Check that the skirts have been evenly shrunk and appear symmetrical with no tilt or sag.

**Outdoor Termination is Complete**

#### Standard Termination

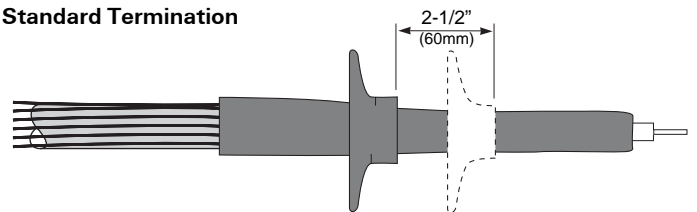

#### Top-Feed Termination

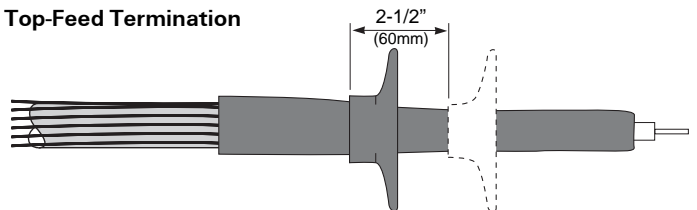

## CHOICE 2

### Unjacketed Concentric Neutral Cable

#### 17. Clean Cable; Apply Red Sealant Onto Semi-con

Using an oil-free solvent, clean the semi-con as shown.

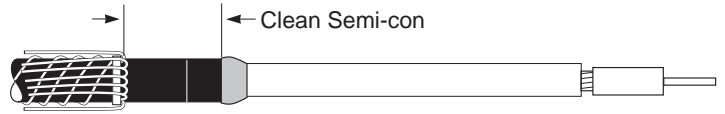

501

Remove the backing from the red sealant. Using light tension, wrap two layers of red sealant onto the semi-con adjacent to the wire bend back as shown.

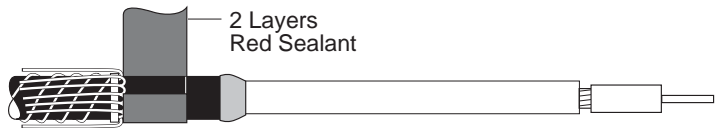

502

#### 18. Apply Red Sealant

##### a. With Lug (or lug and shim)

Using light tension, wrap red sealant on lug barrel (or over shim). Build up lug diameter to cable insulation and overlap insulation by 1/2" (10mm).

##### b. Without Lug

Wrap two layers of red sealant onto the cable insulation as shown.

##### a. With lug (or lug & shim)

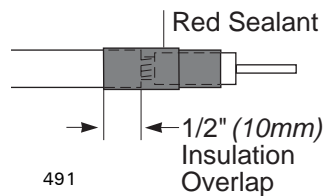

491

##### b. Without lug

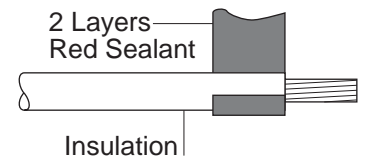

492

#### 19. Position the HV Tube In Place

The bottom end of the tubing should be level with the red sealant on the cable semi-con.



527b

#### 20. Shrinking HV Tube

Shrink the tubing down starting at the semi-con cutback. Heat the area well but avoid scorching the surface. Continue shrinking towards the cable lug. Finally shrink down the bottom end of the tubing. The numbers in the drawing indicate the shrink sequence.

**Note:** After installation the termination must be post heated until a bead of sealant (green) appears around the top of the tubing. Allow the termination to cool before applying any mechanical strain.

**Note:** Due to the lubricating effect of the inner surface coating, there will be some longitudinal shrinkage of the tube.

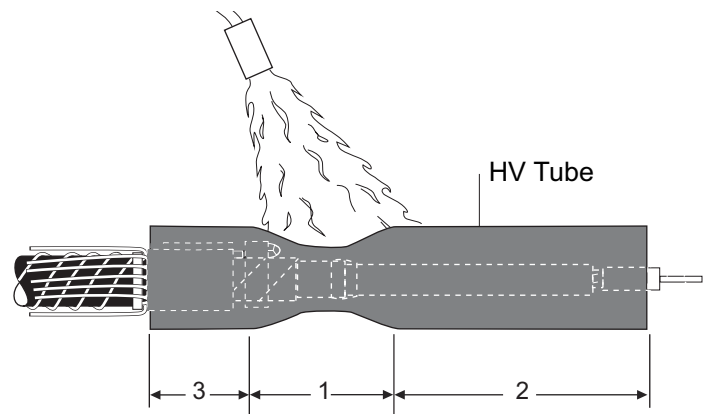

527c

## 21. Trim HV Tube

Trim excess tubing from the lug area as shown.

Twist neutral wires to make a ground lead.

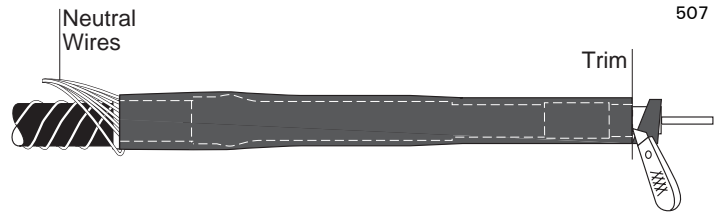

## 22. Inspect Installation

Reheat any flat spots or wrinkles.

Indoor Termination for Unjacketed Concentric Neutral cable is complete.



## 23. Outdoor Termination Only

Position the skirt as shown and shrink in place. Hold the edge of the skirt lightly with pliers. Brush flame tip around outside of skirt collar. Only the collar will shrink.

This completes the 15kV termination. Additional skirts are required for the 25/35 kV termination.

### Standard Termination

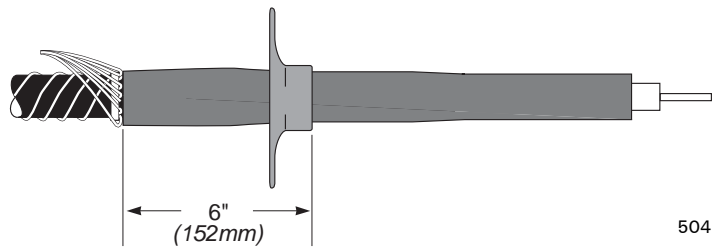

### Top-Feed Termination

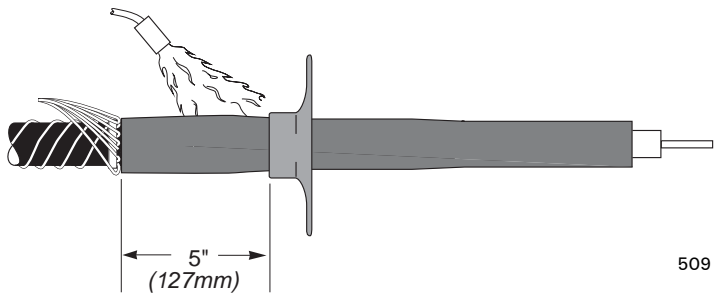

## 24. Position Remaining Skirts and Shrink in Place.

The 25/35kV kits have four skirts. Position the remaining skirts (facing the same direction as the first) as required for the voltage class and shrink them in place. Check that the skirts have been evenly shrunk and appear symmetrical with no tilt or sag.

Outdoor Termination is Complete

### Standard Termination

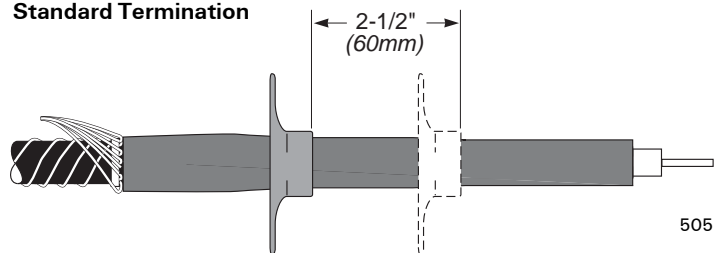

### Top-Feed Termination

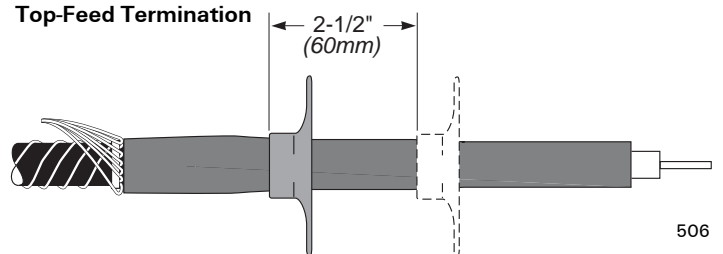



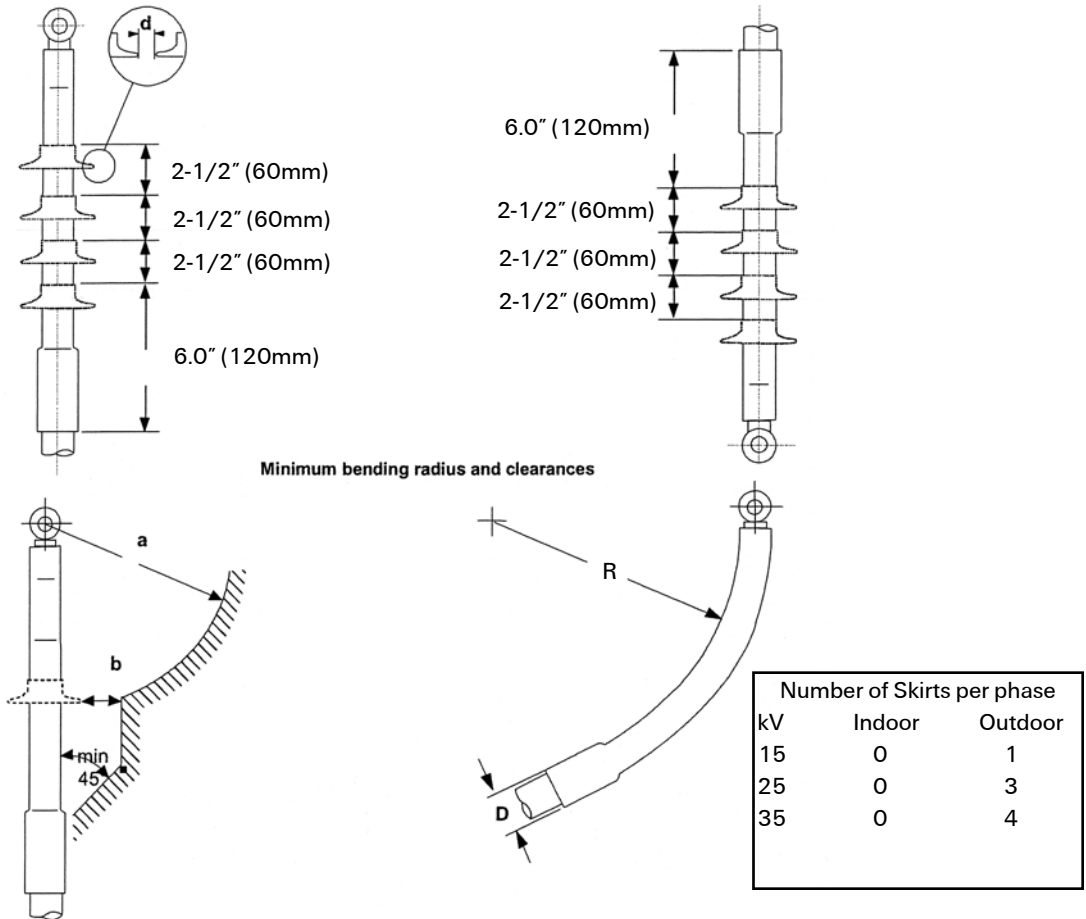

Number of Skirts per phase		
kV	Indoor	Outdoor
15	0	1
25	0	3
35	0	4

Minimum Clearances	Maximum System voltage in kV		
	15	25	35
a Air Clearance	as for local specifications		
b ph/ph and ph/ground in mm	0.75" (20mm)	1.0" (25mm)	1.40" (35mm)
c Between skirts in mm	0.60" (15mm)	0.75" (20mm)	1.0" (25mm)

### Recommended Cable Bending Radius

Tyco Electronics terminations are as flexible as the original cables. A cable end should not be bent to a radius less than that recommended by the manufacturer.

$D$  = Cable Jacket O.D.

$R = 10 \times D$  - Minimum bending radius (consult cable manufacturer's values and check them against Tyco Electronics'. Select the higher of the two. Preheat cable to approximately 80 degrees before bending.)

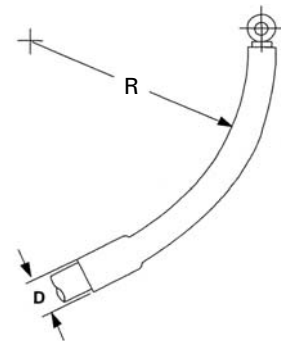

Figure 5: Bending Radius

The Information contained in these installation instructions is for use only by installers trained to make electrical power installations and is intended to describe the correct method of installation for this product. However, Tyco Electronics has no control over the field conditions which influence product installation. It is the user's responsibility to determine the suitability of the installation method in the user's field conditions. Tyco Electronics' only obligations are those in Tyco Electronics' standard Conditions of Sale for this product and in no case will Tyco Electronics be liable for any other incidental, indirect or consequential damages arising from the use or misuse of the products. Raychem is a trademark of Tyco Electronics Corporation.