

CUSTOMER HOTLINE 1 800 722-1111

**SHIELDED CHAMP KIT**

CONT POSN	CONNECTOR ASSY		PART NO.**
	SLOT SIZE	DESCRIPTION	
24	E	Bail Lock Plug	554947-1
	B	Bail Lock Plug	554947-2
	B	Screwlock Plug	554948-2
	E	Metric Screwlock Plug	554948-3
	B	Metric Screwlock Plug	554948-4
36	E	Bail Lock Plug	554950-1
	B	Bail Lock Plug	554950-2
	B	Screwlock Plug	554951-2
50	E	Bail Lock Plug	554953-1
	B	Bail Lock Plug	554953-2
	E	Screwlock Plug	554954-1
	B	Screwlock Plug	554954-2
	E	Screwlock Rcpt	554955-1
	B	Screwlock Rcpt	554955-2

\*\* ALL PART NUMBERS LISTED ARE FOR INDIVIDUAL KITS PACKAGED IN POLY BAGS. THE SAME PART NUMBER WITH A PREFIX (5-) INDICATES BULK PACKAGING (500 Kits Per Box).

**INNER FERRULE**

I.D.*	PART NO.	USED WITH
.250	554725-1	24 Posn Only
.300	554725-2	24 and 36 Posn
.350	554725-3	24, 36, and 50 Posn
.400	554725-4	36 and 50 Posn
.450	554725-5	50 Posn Only

\* INSIDE DIAMETER (I.D.) OF INNER FERRULE. SELECT INNER FERRULE I.D. ACCORDING TO DIAMETER OF CABLE JACKET OR BRAID DIAMETER.

**COVER KIT**

PART NO **	USED WITH
554944-1	24-Posn Assy
554945-1	36-Posn Assy
554946-1	50-Posn Assy†
554946-2	50-Posn Assy††

† CABLE JACKET DIAMETER LESS THAN .500 IN.  
†† CABLE JACKET DIAMETER .500 TO .625 IN.

Fig. 1

**1. INTRODUCTION**

This instruction sheet (IS) covers the assembly of the shielded CHAMP 180° plug and receptacle components shown in Figure 1.

Read these instructions thoroughly before starting assembly.

**NOTE** All dimensions given in this instruction sheet are in inches unless otherwise specified.

**2. DESCRIPTION**

The shielding components shown in Figure 1 are designed to reduce problems of EMI/RFI (electromagnetic interference/radio frequency interference) at the interface of CHAMP connectors.

The connector kits include a plug or receptacle assembly and two nickel-plated shields (inner and outer). Select the connector kit according to the bail

## IS 3188

lock or screw lock hardware to be used. The shields are held together with locking tabs, and held onto the connector with locator tabs. Shields also feature spring fingers at the cable exit for braid contact. The 24-position connector assembly will accept .300- thru .400-in. cable jacket diameters. The 36-position connector assembly will accept .300- thru .450-in. cable jacket diameters. The 50-position connector assembly will accept .350- thru .625-in. cable jacket diameters.

An inner ferrule must be ordered separately and used with the connector kit.

The cover kits include a strain relief insert and two snap-on covers (see Figure 1).

### 3. ASSEMBLY PROCEDURE

#### A. Cable Preparation (Braid Shield)

Strip the outer cable jacket 6 in. from the end of the cable (see Figure 2).

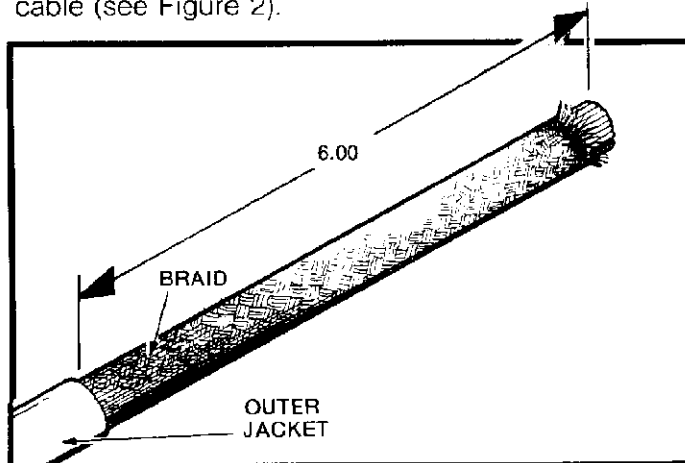

Fig. 2

#### B. Ferrule Application (Small Diameter Cable)

1. Slide inner ferrule over outer cable jacket and stop flush with end (see Figure 3).

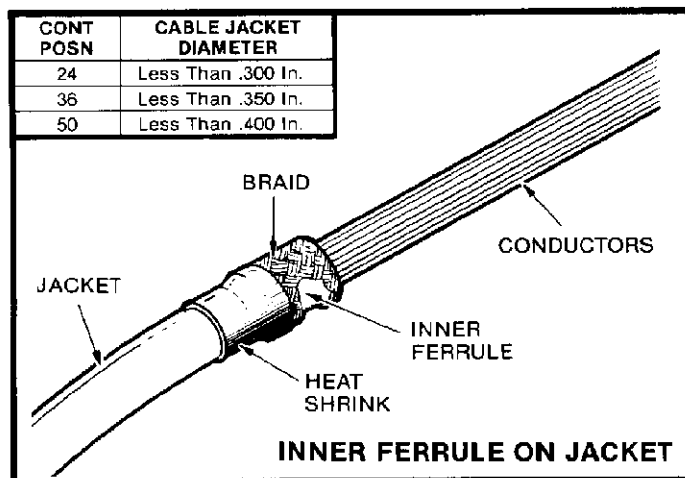

Fig. 3

## CHAMP 180° SHIELDED CONNECTOR KITS

2. Trim braid 1 in. from end of outer jacket. Fold cable braid over inner ferrule and outer jacket. Make sure braid is spread evenly around the circumference of the inner ferrule. Trim braid .125 in. beyond inner ferrule and use tape or heat-shrink tubing to contain the loose ends.

#### C. Ferrule Application (Large Diameter Cable)

1. Slide inner ferrule over cable braid and position at end of outer jacket (see Figure 4).

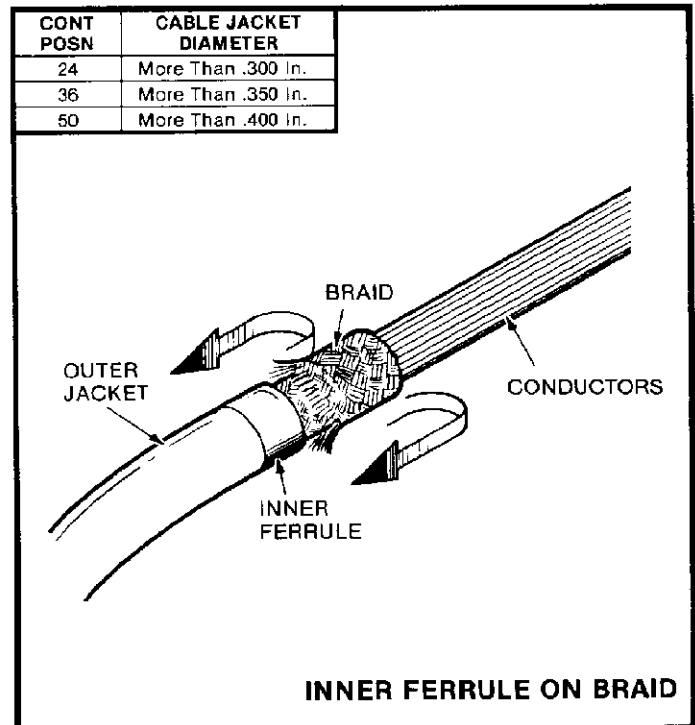

Fig. 4

2. Trim braid 1 in. from end of inner ferrule. Fold cable braid over inner ferrule and outer cable jacket. Make sure the braid is spread evenly around the circumference of the inner ferrule.

3. Trim braid .125 in. beyond inner ferrule and use tape or heat-shrink tubing to contain the loose ends.

#### D. Foil Shield Application

1. Strip outer cable jacket 6 in. from the end of the cable (see Figure 2).

2. Wrap foil (conductive side out) over the jacket and tape the loose end. *Do not use the inner ferrule when the cable has a foil shield.*

**E. Cable Termination**

Terminate cable conductors into connector assembly. Contact your local AMP Sales Engineer for different types of tooling and procedures.

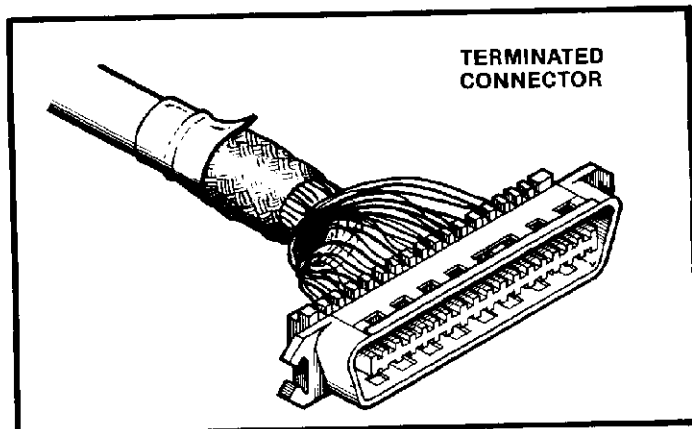

Fig. 5

**F. Shielding Assembly**

1. Align connector with inner shield so that connector locator tabs on shield grasp the connector (and the spring fingers protrude through the holes in the plug housing). Dress cable as required to ensure the cable will not be pinched by the outer shield. See Figure 6.

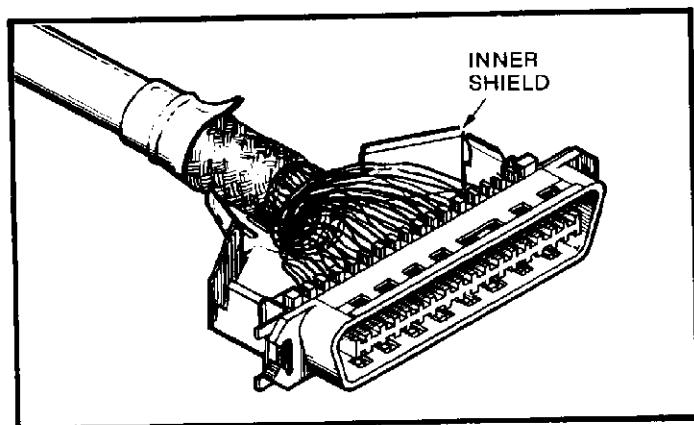

Fig. 6

2. Place outer shield over connector and inner shield. Locate spring fingers at cable exit over braid on inner ferrule. Snap shields together ensuring braid is in contact with spring fingers and no wires are pinched with shields. Locking tabs of inner shield should be visible through windows of outer shield. Parallel jaw pliers may be used to close shields when a large cable is used. See Figure 7.

3. The connector assembly is now ready for post molding or a plastic cover assembly.

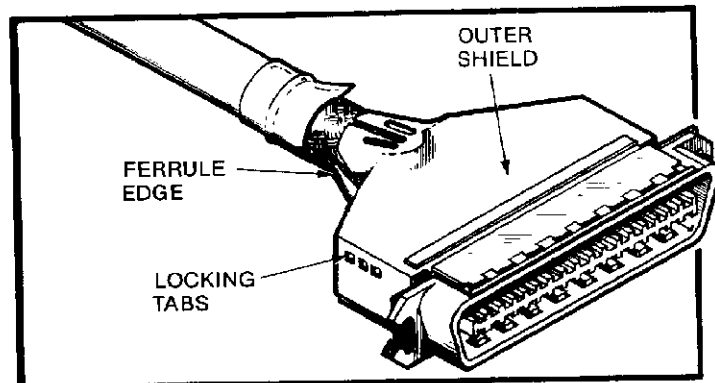

Fig. 7

**4. COVER KIT ASSEMBLY**

The cover kit protects the connector and provides cable strain relief.

1. Determine the number of contact positions in your connector. Refer to the chart in Figure 1 and select the appropriate cover kit.
2. Press shielded assembly into tongue side of cover by sliding cover tabs in slots where outside shield overlaps inside shield (see Figure 8).

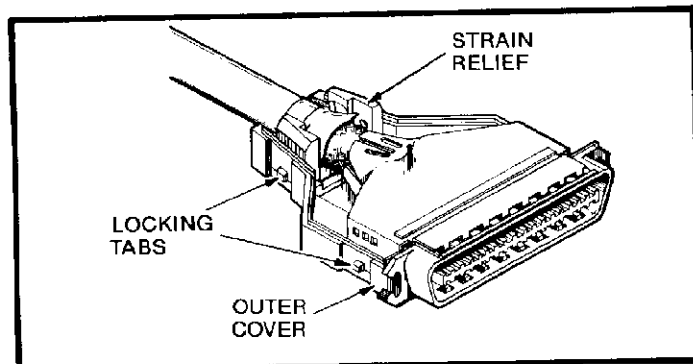

Fig. 8

3. Place strain relief on cable and engage into ratchet teeth of cover. Tighten ratchet until desired pull-out is obtained.
4. Place groove side of cover over assembly and press until locking tabs engage (see Figure 9).

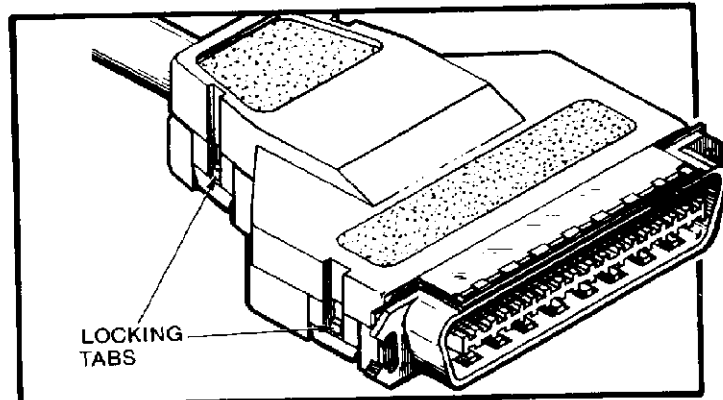

Fig. 9