

AMP

AMP INCORPORATED
HARRISBURG, PA 17105

AMP* SMB 50-OHM AND 75-OHM STRAIGHT AND RIGHT-ANGLE RECEPTACLE CONNECTORS

IS 2987-8

CUSTOMER HOTLINE
1 800 722-1111

RELEASED
9-24-91

SMB 75-OHM RECEPTACLE CONNECTOR 221222 (Ref)

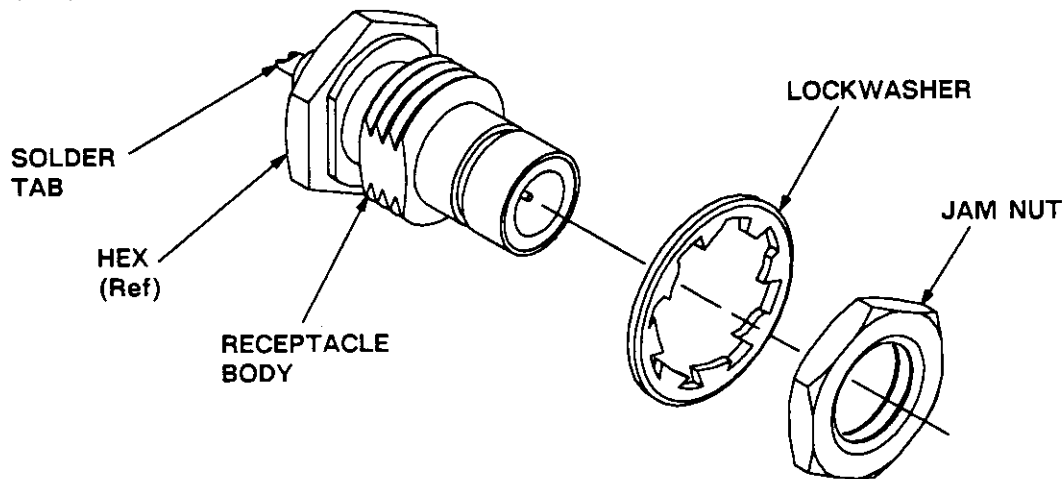

CONNECTOR PART NUMBER	IMPEDANCE	CONNECTOR TYPE	PANEL MOUNT APPLICATION
228216	50 ohm	STRAIGHT	FRONT
414022	50 ohm	RIGHT ANGLE	
221225	75 ohm	STRAIGHT	
228215	50 ohm	STRAIGHT	REAR
221222	75 ohm	STRAIGHT	

Fig. 1

cad

1. INTRODUCTION

This Instruction Sheet (IS) covers the installation of AMP SMB 50-Ohm and 75-Ohm Receptacle Connectors for front and rear panel mount applications. See Figure 1.

Read these instructions carefully before installing connectors.

NOTE

Dimensions on this instruction sheet are in millimeters followed by inches in brackets.

2. DESCRIPTION (Figure 1)

Each connector consists of a receptacle body, a solder tab, a lockwasher, and a jam nut. The connectors can be mounted from the center to the outer edge of a 2.36 [.093]-thick maximum pc board.

3. INSTALLATION

1. Punch D-shaped hole into panel using the appropriate panel cutout dimensions provided in Figure 2.
2. Insert threaded portion of receptacle connector through panel cutout, as shown in Figure 3, A and B.
3. Slide lockwasher onto the end of the receptacle body until lockwasher is positioned against the panel. To secure lockwasher, thread jam nut onto end of receptacle body and tighten.

NOTE

For panels less than 0.9 mm [20 gauge or .036 in.], hold hex nut on body of connector (when installing jam nut and lockwasher) to avoid damage to the connector and/or panel mount.

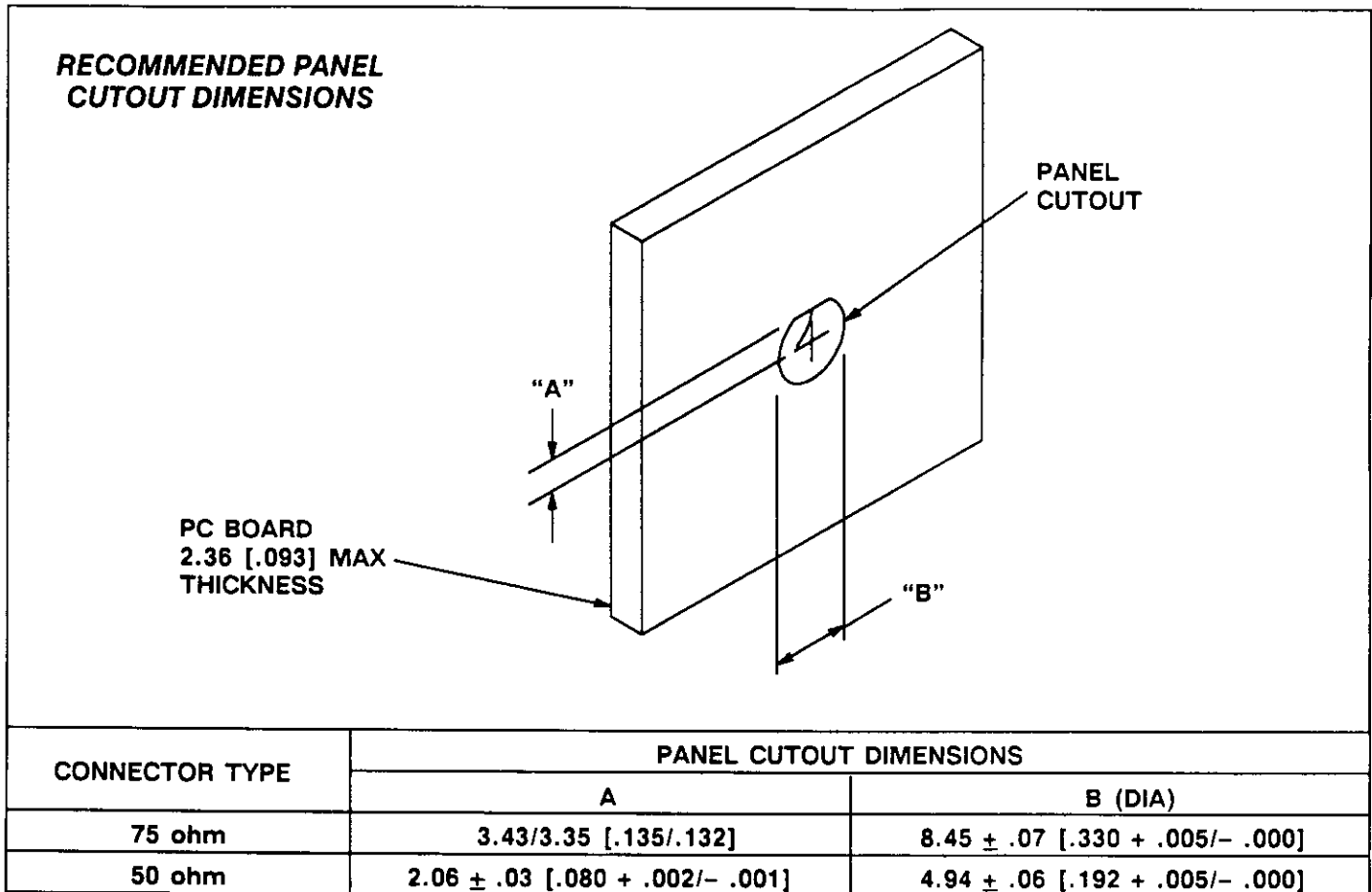

Fig. 2

cad

NOTE

Recommended tightening torque of the jam nut is .452 -.678 N·m [4 to 6 in-lb.].

4. Solder wire to solder tab using standard soldering techniques.

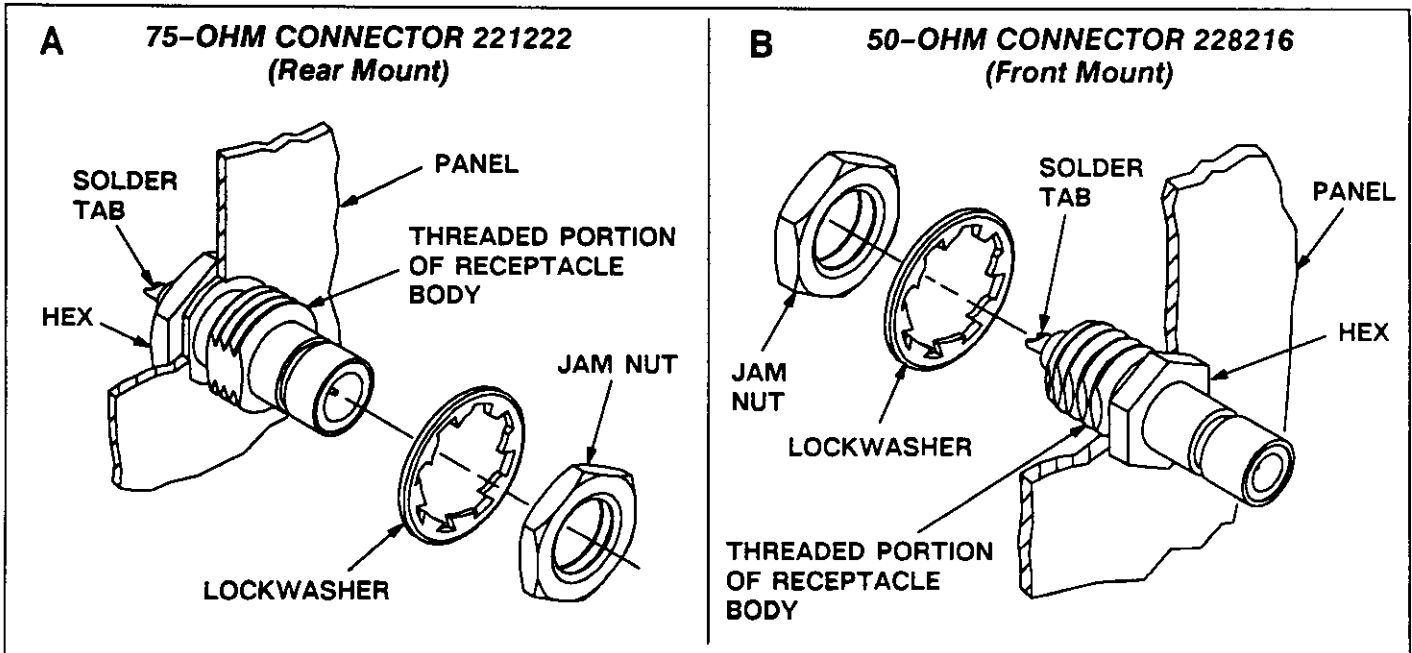

Fig. 3

cad