



**AMPACT ★ TAP AND  
TAP COVERS FOR UNDERGROUND  
RESIDENTIAL DISTRIBUTION (URD)**

<b>IS 2584</b>	
RELEASED	12-5-74
REVISED	3-10-75

**1. INTRODUCTION**

AMPACT tap covers, combined with the standard AMPACT tap, provide an effective method of making an insulated moisture-proof connection. This connection is designed for use in direct burial and ducted installations, above or below grade, in various types of soil and in various climates.

**2. TAP COVER**

The tap cover (Figure 1) is a two-piece molded plastic cover consisting of a cover base and a cap. The cap contains a row of notches on each side to mate with latches on the cover base which contains a piston and the sealing compound. Projecting from the cover base are one or two reducers that may be trimmed to conform to the variety of sizes of insulated conductors. As the cover is closed, the latches engage the notches and the piston forces the sealing compound around the insulated conductor, sealing the connection. This sealing action protects the connection from oxidation and corrosion.

**3. SELECTION**

The selection chart (Figure 2) lists available tap cover sizes, conductor insulation diameter ranges accommodated by the various sizes, and the required conductor strip lengths.

TAP COVER		CONDUCTOR INSULATION DIA. RANGE	CONDUCTOR STRIP LENGTH
PART NUMBER	SIZE		
602179	SMALL	.200"-.500"	1-1/2"
602178	MEDIUM	.300"-.820"	2-3/8"
602235	MEDIUM	.600"-.925"	2-3/8"

Figure 2

**4. APPLICATION**

- (a) Strip each conductor, as shown in Figure 3, to strip length specified in Figure 2 (do not over-strip), and use wire brush to thoroughly clean exposed conductor.

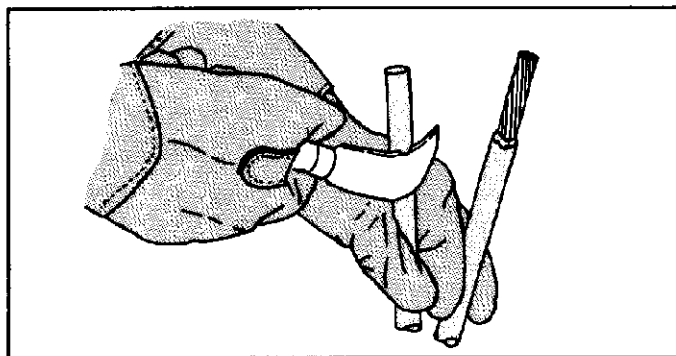

Figure 3

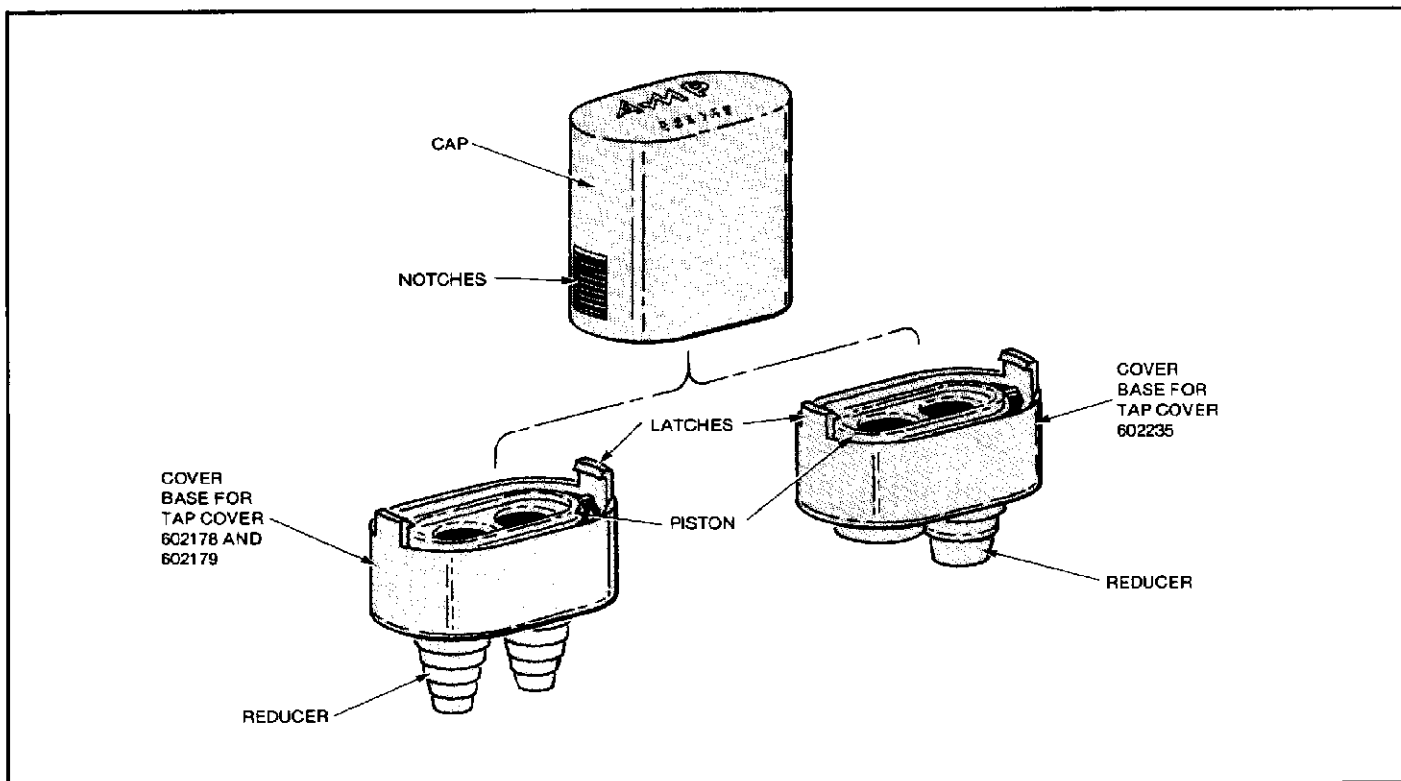

Figure 1

Copyright 1974, 1975 by AMP Incorporated, Harrisburg, Pa. All International Rights Reserved. AMP Incorporated products covered by U.S. and Foreign Patents and/or Patents Pending.

- (b) Determine reducer ring diameter necessary for insulation size of one conductor, as shown in Figure 4, and cut off reducer at ring selected. See Figure 5.
- (c) Repeat step (b) for other conductor, cutting off other reducer at selected ring, as shown in Figure 5.
- (d) Place cover base over stripped conductors, as shown in Figure 6.

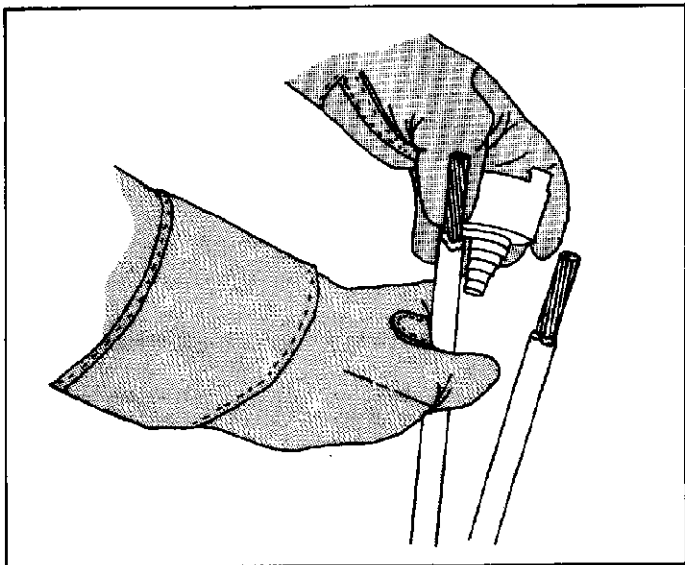

Figure 4

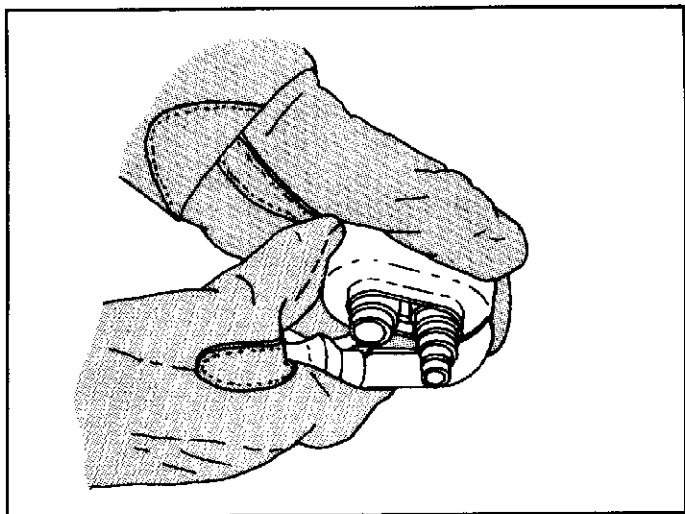

Figure 5

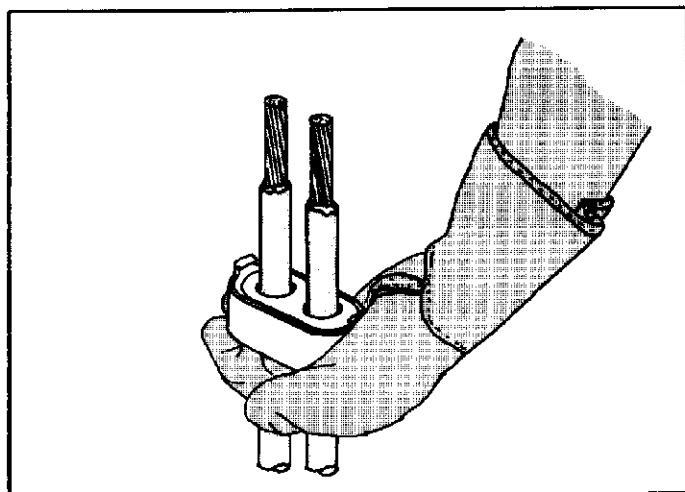

Figure 6

- (e) Center "C" member of AMPACT tap on stripped conductors and insert wedge, as shown in Figure 7.
- (f) Apply tap, using standard procedures and observing SAFETY PRECAUTIONS described in Customer Manual CM 2106, packaged with AMPACT tool. See Figure 8. Keep face away from line of action when firing tool.

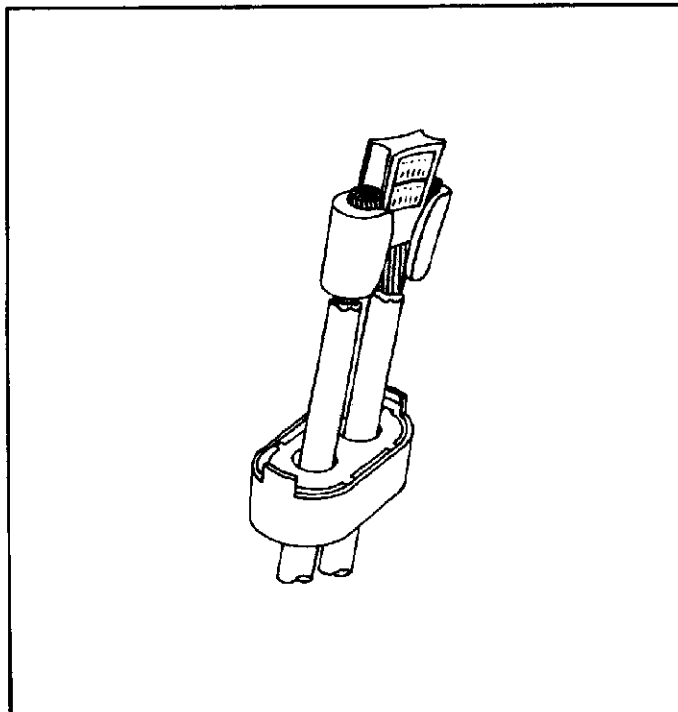

Figure 7

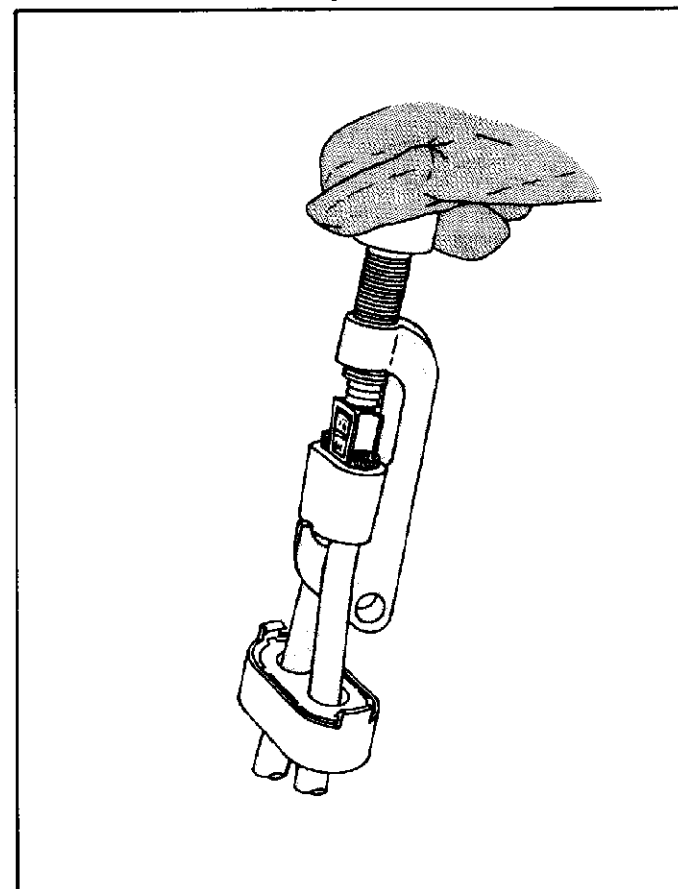

Figure 8

- (g) Wipe all inhibitor from sealing area of cover base and from conductor insulation. See Figure 9.
- (h) Squeeze cover base against tap tightly by hand, as shown in Figure 10.
- (i) Place cap over tap and push onto cover base. Squeeze base and cap together tightly by hand. See Figure 11.



Figure 9

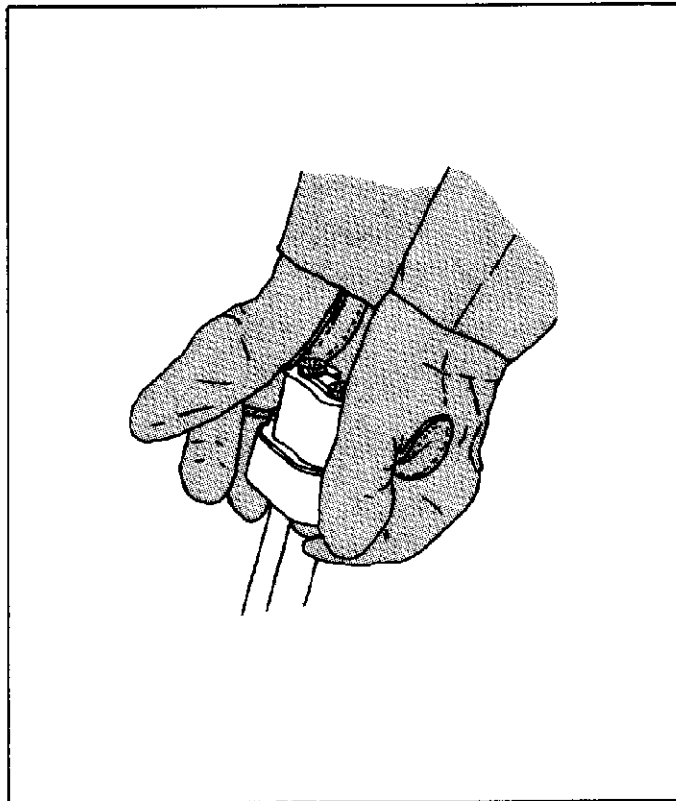

Figure 10

- (j) Attach cover-closing tool, catalog number 69882, and turn knob clockwise to close cover, as shown in Figure 12.
- (k) When last notch is engaged on the cap, operation is complete and connection is sealed (Figure 13). Remove cover-closing tool by turning knob counter-clockwise.

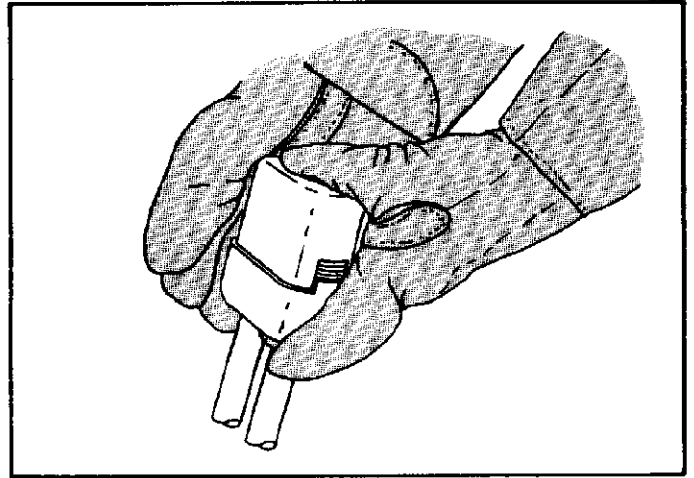

Figure 11

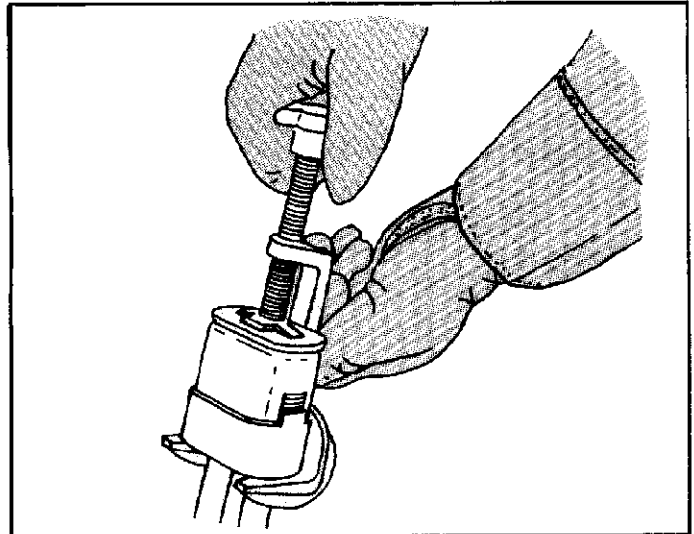

Figure 12

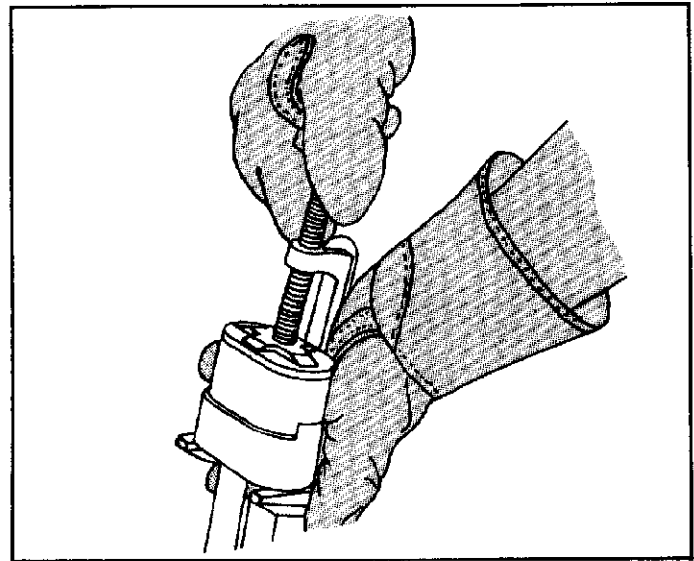

Figure 13

## 5. COVER REMOVAL

If necessary, the tap cover can be removed. It cannot, however, be used again after removal. Use the following procedure for tap cover removal.

- (a) Pry latches away from cap. See Figure 14.
- (b) Remove cap and slide base down on conductors for tool clearance.
- (c) Remove tap, using standard procedures, as described in CM 2106, packaged with AMPACT tool.
- (d) Remove cover base.

NOTE: AMP\* sealing and dielectric compounds for use in sealing exposed surfaces are listed in Figure 15.

SEALING AND DIELECTRIC COMPOUND	
PART NUMBER	DESCRIPTION
275447-1	ROLL (1/8" x 3-3/4" x 10 Ft.) †
275447-2	ROLL (1/8" x 3-3/4" x 10 Ft.) ††
275442-1	25 PADS (1/8" x 3-3/4" x 3-3/4") ††
275446-1	ROLL (1/8" x 5" x 10 Ft.) ♦

† Protective paper, one side  
 †† Protective Paper, both sides  
 ♦ Mylar backing, one side

Figure 15

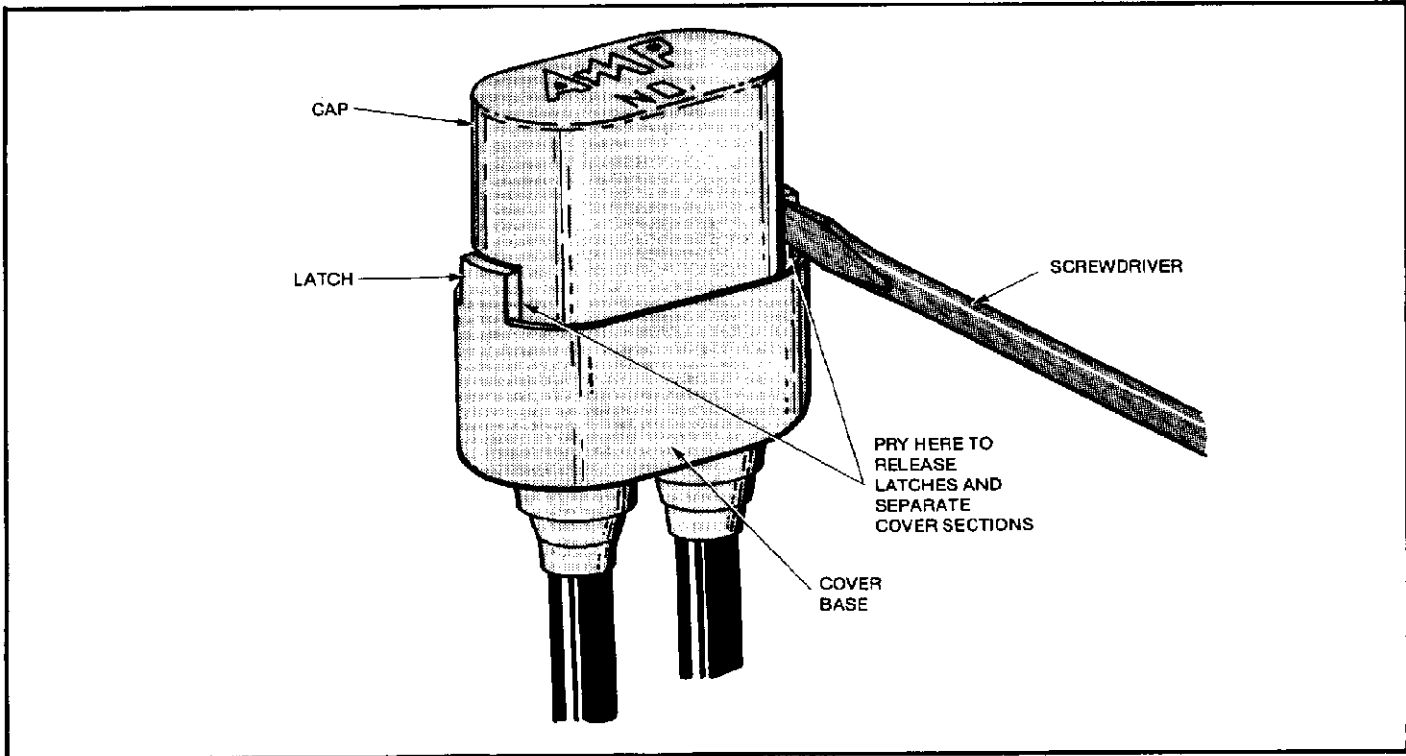

Figure 14