

STANDARD THREADED COAXICON CONNECTORS

CABLE NO	PART NUMBER - PRODUCT			DIELECTRIC MATERIAL	CABLE STRIP LENGTH	HAND TOOL	DIE (FOR 69365-2 or 69710)
	PLUG	RECEPTACLE	FERRULE†				
141	--	2-329031-4	330478	Polypropylene	Fig. 3A	45740	69220-1
						45740 Mod L	
55, 55A, 55B, 142, 223	--	2-329031-2	329099			69248-1	69315-1
						69248-1 Mod H	
58, 58A, 58B, 58C	2-329030-1	2-232031-1	328663			45740	69220-1
						45740 Mod L	
59, 59A, 59B, 62, 62A, 62B, 124, 140, 210	--	2-329033-1	329041			69126	69225-1
						69126 Mod G	

STANDARD THREADED COAXICON CONNECTORS

CABLE NO	PART NUMBER - PRODUCT			DIELECTRIC MATERIAL	CABLE STRIP LENGTH	HAND TOOL	DIE (FOR 69365-2 or 69710)
	PLUG	RECEPTACLE	FERRULE†				
174, 188, 21-596, 21-598	2-329036-1	--	329038	Polypropylene	Fig. 3C	45609	69226-1
	2-330311-1	--		PTFE		45609 Mod P	
179A, 187	2-329036-1	--		Polypropylene		69142	69228-1
	2-330311-1	--		PTFE		69142 Mod H	
161, 178, 178A, 196	--	2-330312-2 2-330312-3	329067	PTFE	Fig. 3B	69188-1 Mod F	69372
174, 179, 187, 188, 21-596, 21-598	--	2-330312-1 2-330312-4	329038	PTFE	Fig 3C	69142 Mod H	69228-1

† Ferrule part numbers are shown for reference only since they are included with assemblies.

Figure 1

1. INTRODUCTION

This instruction sheet covers the selection and assembly of the threaded type COAXICON Connectors listed in Figure 1. These connectors, consisting of standard threaded and miniature threaded COAXICON connectors, are designed to be terminated to the variety of coaxial cable listed in Figure 1.

Read these instructions thoroughly before starting assembly or termination.

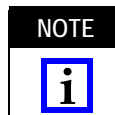

Dimensions in this instruction sheet are in metric units [with U.S. customary units in brackets]. Figures are not drawn to scale.

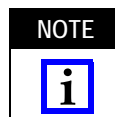

Current production hand tools are identified by the model letter designations listed in Figure 1. See instruction sheet 408-1771-2 for crimping instructions for these tools. Refer to instruction sheet 408-1771-3 for crimping procedures for the interchangeable dies listed.

Reasons for reissue of this document are provided in Section 7, REVISION SUMMARY.

2. CABLE PREPARATION

Before stripping the cable, slip plug retaining nut and one ferrule on the cable as shown in Figure 2. Then proceed as follows:

FERRULE ASSEMBLY

Slide Ferrule on Wire, Folded End First, then Strip Wire

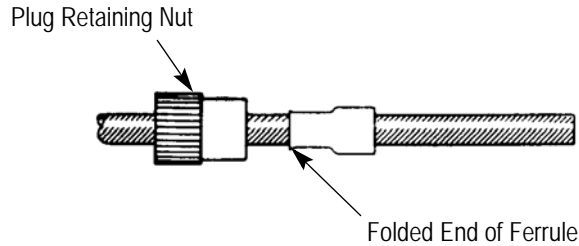

Figure 2

1. Slip another ferrule on the other cable. See Figure 2.

NOTE

Slide ferrule - folded end first - over cable.



2. Find the figure reference under the Cable Strip Length column in Figure 1 for the specific connector and cable being used. Strip cable to dimensions indicated under the appropriate section in Figure 3.

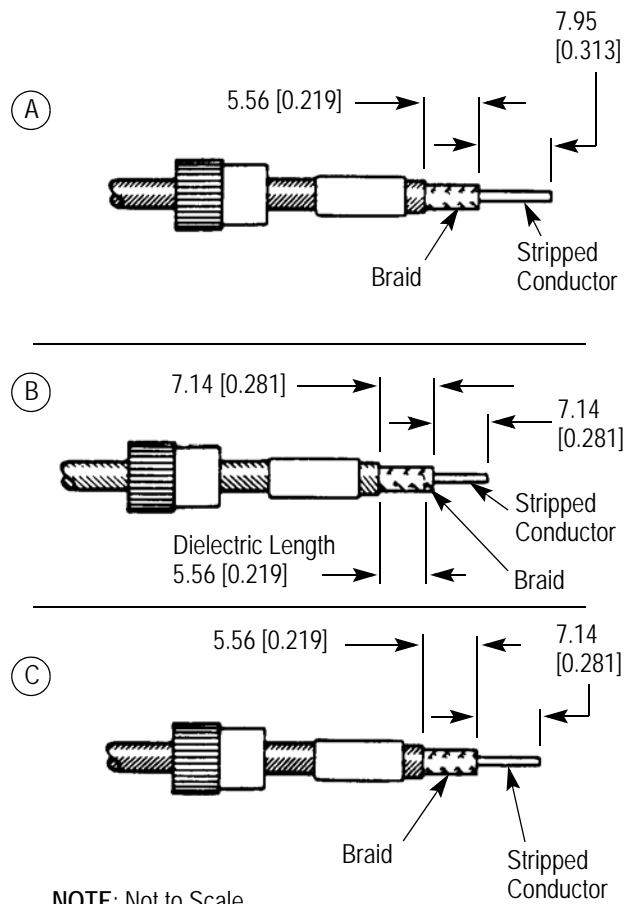
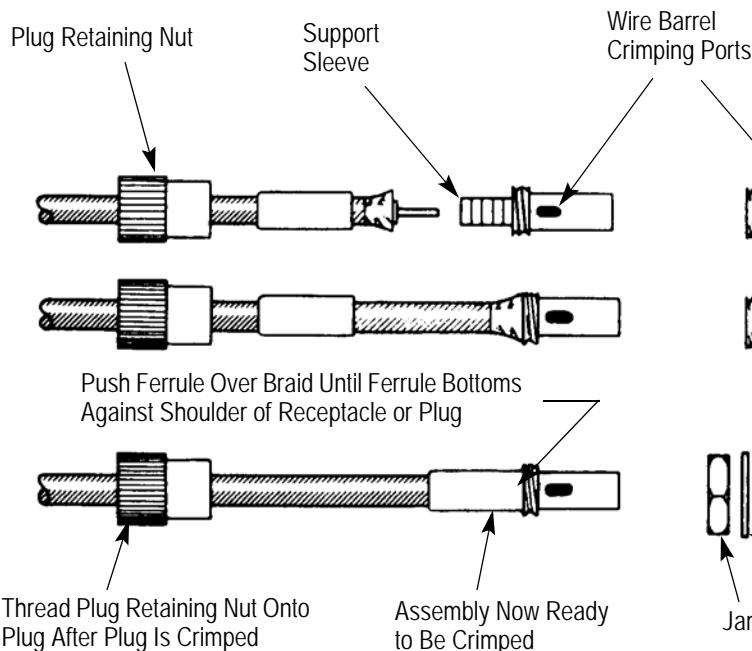

Figure 3

TYPICAL PLUG ASSEMBLY



TYPICAL RECEPTACLE ASSEMBLY

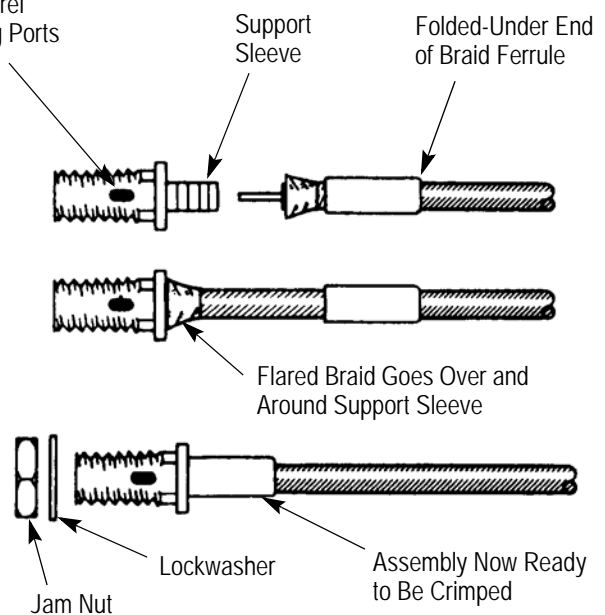

Figure 4



ADAPTER	PART NUMBER
 <p><i>Tee Adapter</i></p>	329096 Miniature
 <p><i>Angle Adapter</i></p>	329097 Miniature
 <p><i>Feed-Thru Adapter</i></p>	330118 Miniature
 <p><i>Printed Circuit Board Adapter</i></p>	330119 Standard
	331899 Miniature
 <p><i>Solder Receptacle</i></p>	329852 Miniature
	329852-1 Miniature (PTFE Dielectric)

Figure 5

3. ASSEMBLY PROCEDURE

The steps which follow are recommended to assemble the cable for termination. Use the applicable illustration for the specific connector being used. Proceed as follows:

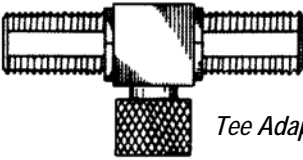
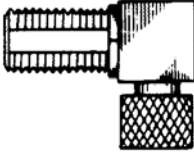
1. Hold ferrule in place and insert the stripped conductor into the wire barrel of connector. Turn plug or receptacle slightly to ease insertion of the stripped conductor. See Figure 4.
2. Push ferrule forward and over support sleeve of connector as far as it will go. Connector is now ready to be crimped to cable. Refer to Figure 4.
3. Crimp connector to the cable, using the information listed in Figure 1 and by following the instructions in the instruction sheet packaged with the tooling.

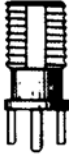
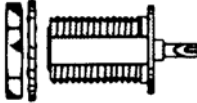
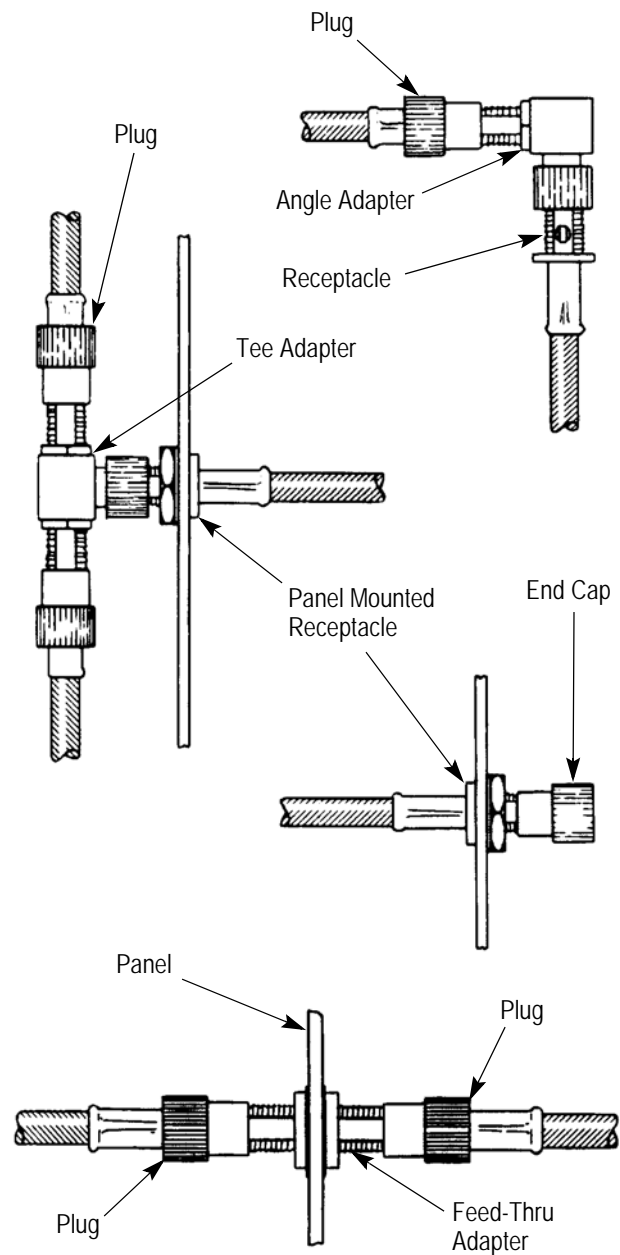

Figure 6

4. ADAPTERS AND END CAPS

Threaded type COAXICON adapters, shown in Figures 5 and 6, are used with the connectors listed in Figure 1. Use the adapters as required in either free-hanging or in panel-mounting applications.

End caps are used on the open side of tee adapters, or to protect the threaded end of other receptacles. See Figure 6. They are used with both standard and miniature threaded type receptacles.

When coupling receptacle to angle or tee adapter, first turn collar several complete turns, then push receptacle "IN" until it bottoms. Turn collar tight.

5. PANEL MOUNTING DIMENSIONS

The dimensions shown in Figure 7 are outside dimensions for threaded type receptacles. The actual cutout is not shown because of variations in mounting requirements. Use Figure 7 as a guide for panel cutouts.

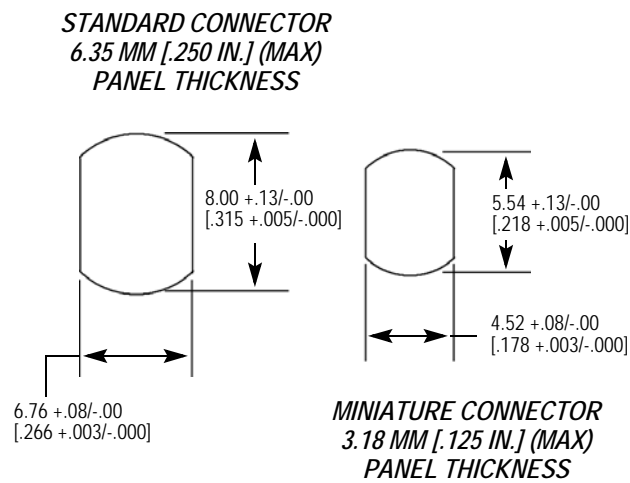

Figure 7

6. PANEL INSULATING BUSHINGS

Bushings are available for use in insulating standard and miniature connectors when those connectors are panel mounted. Both bushings contain internal flats to prevent the receptacle from turning inside the bushing. See Figure 8. External flats prevent the bushings from turning inside the panel.

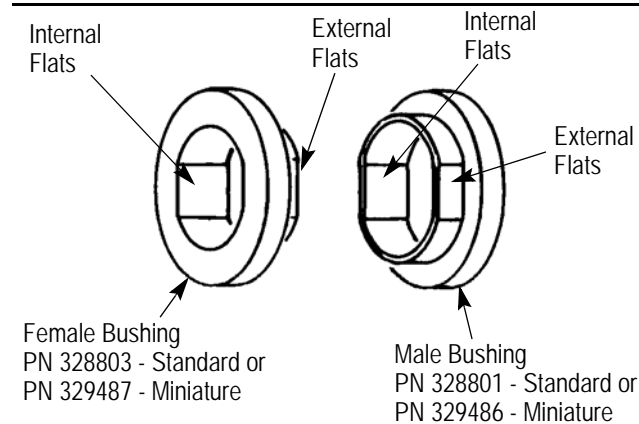

Figure 8

To determine the panel cutout dimensions, refer to Figures 9 and 10. Attach male and female bushings to panel as shown in Figure 11. The manner of assembly is the same for both standard and miniature COAXICON connectors.

PANEL CUTOUT FOR PN 328803

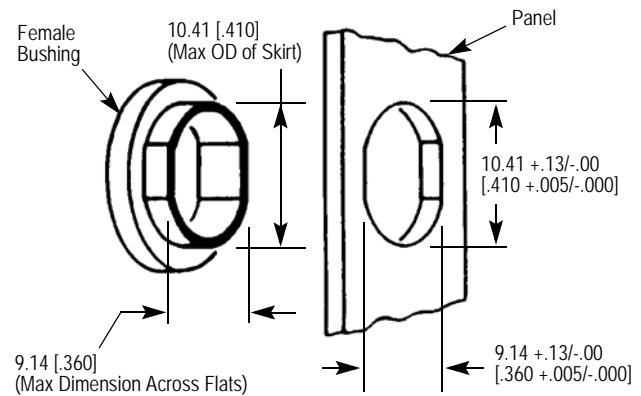

Figure 9

PANEL CUTOUT FOR PN 329487

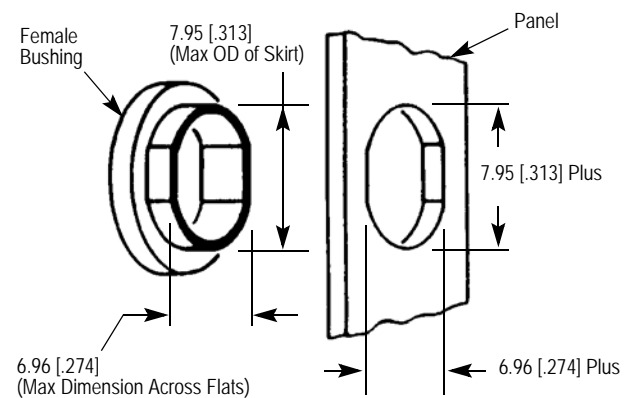

Figure 10

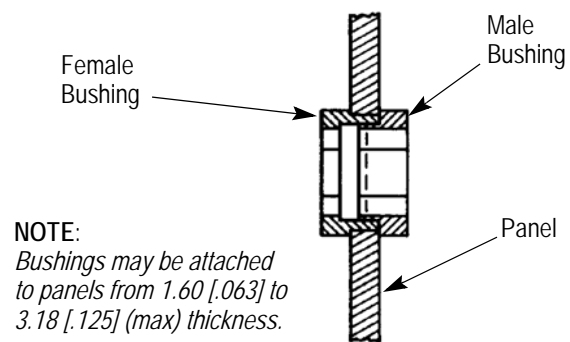

Figure 11

7. REVISION SUMMARY

Since the previous version of this document, the following changes were made:

- Added metric dimensions.
- Removed improper trademark references for PTFE material.
- Updated document to corporate requirements.