

Instruction Sheet (Class 1)

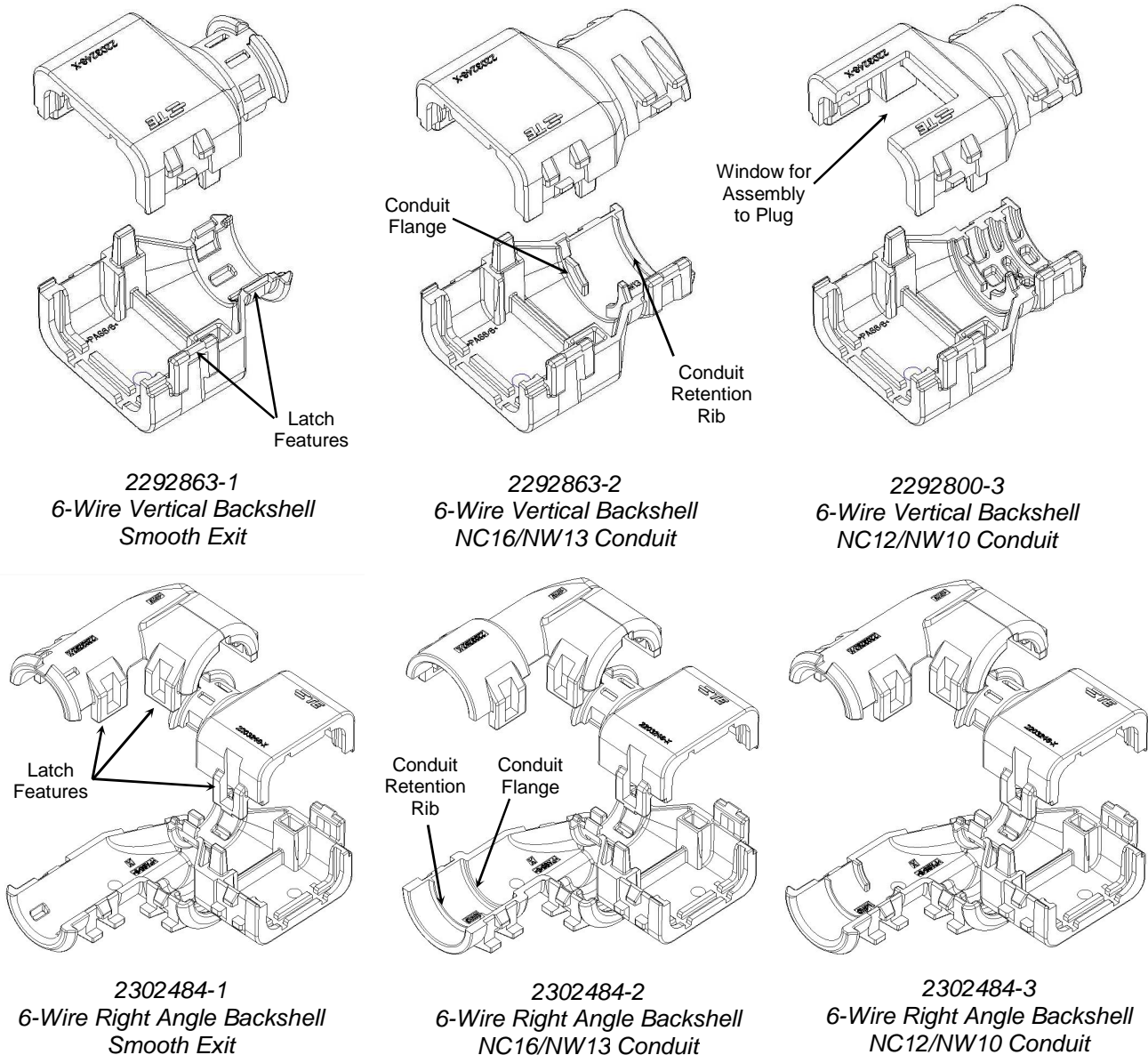

Figure 1

1. INTRODUCTION

AMPSEAL 16 Vertical and Right Angle Backshells are designed to provide protection to the harness wires of the AMPSEAL 16 Plug and Receptacle Connectors. The basic versions are shown in Figure 1.

Read these instructions carefully before assembling either backshell version.

2. PRODUCT DESCRIPTION

The two-piece vertical backshells and four-piece right angle backshells are made from UL94 V-0 nylon. The backshells are easily assembled to a plug or receptacle connector of corresponding size, as shown in Table 1. Please note that there are separate backshell part numbers for Plug connectors and Receptacle (Cap) connectors.

Also note that the right angle elbows are not available for purchase as separate part numbers.

Connector Size	Vertical Backshell	Right Angle Backshell
2p Plug	2292797-X	2302488-X
2p Receptacle	2292860-X	2302481-X
3p Plug	2292798-X	2302491-X
3p Receptacle	2292861-X	2302482-X
4p Plug	2292799-X	2302492-X
4p Receptacle	2292862-X	2302483-X
6p Plug	2292800-X	2302493-X
6p Receptacle	2292863-X	2302484-X
8p Plug	2292801-X	2302494-X
8p Receptacle	2292864-X	2302485-X
12p Plug	2292802-X	2302495-X
12p Receptacle	2292865-X	2302486-X

Table 1

Vertical Backshells and Right Angle Backshells of designation -2 and -3 connect to various sizes of conduit, as described in Table 2. (Normal profile conduit only).

Connector Size	Backshell Designation	Conduit Size (NC)	Conduit Size (NW)
2-position	-2	NC12	NW10
	-3	NC08	NW7.5
3-position	-2	NC12	NW10
	-3	NC08	NW7.5
4-position	-2	NC16	NW13
	-3	NC12	NW10
6-position	-2	NC16	NW13
	-3	NC12	NW10
8-position	-2	NC20	NW17
	-3	NC16	NW13
12-position	-2	NC20	NW17
	-3	NC16	NW13

Table 2

3. ASSEMBLY PROCEDURE

A. SMOOTH EXIT APPLICATIONS

1. Terminate the contacts according to the instructions provided with the specific termination tooling (reference 114-13045 Application Specification).
2. Load connector with the terminated wires.

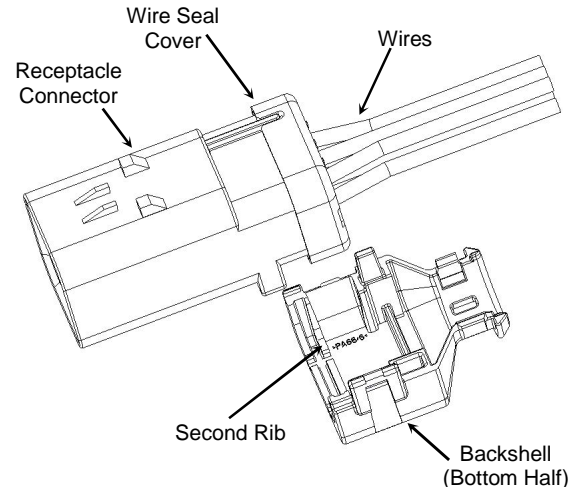

Figure 2

3. Align the plug or receptacle connector and the bottom half of the backshell as shown in Figure 2.
4. Insert the connector into the bottom half of the backshell, so that the wire seal cover is behind the second rib at the opening of the backshell.
5. For assembly to a receptacle connector, turn the top half of the backshell over. Again, insert the connector into the backshell so that the wire seal cover is behind the second rib at the opening of the backshell. Firmly press the two halves together. An audible and tactile click will indicate when they are mated. Visually

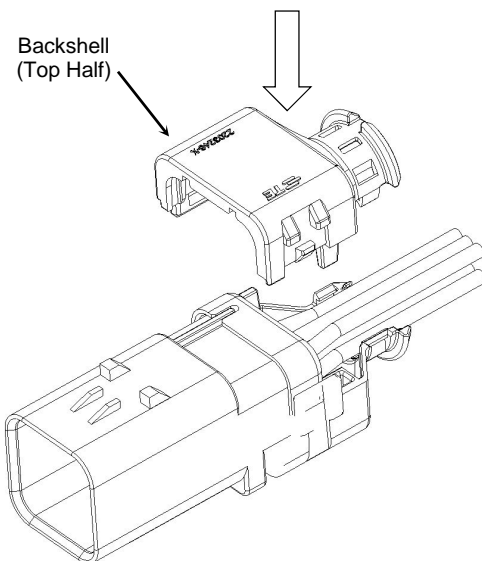

Figure 3

check all the latches for complete engagement. See Figure 3.

- For assembly to a plug connector, be sure to use the backshell with an open window area as the top half. Again, turn the top half of the backshell over and insert the connector into the backshell so that the wire seal cover is behind the second rib at the opening of the backshell. Firmly press the two halves together. An audible and tactile click will indicate when they are mated. Visually check all the latches for complete engagement. See Figure 4.

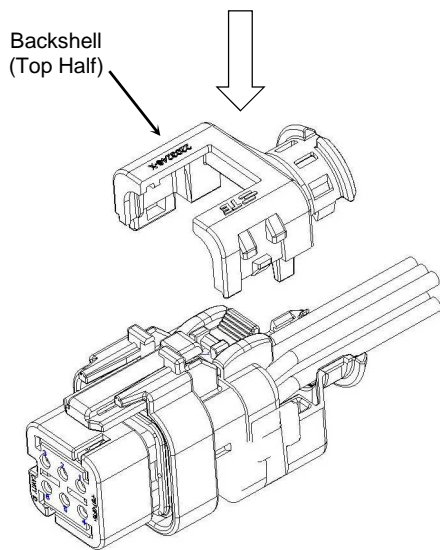

Figure 4

- The complete AMPSEAL 16 Backshell with connectors is shown in Figure 5.

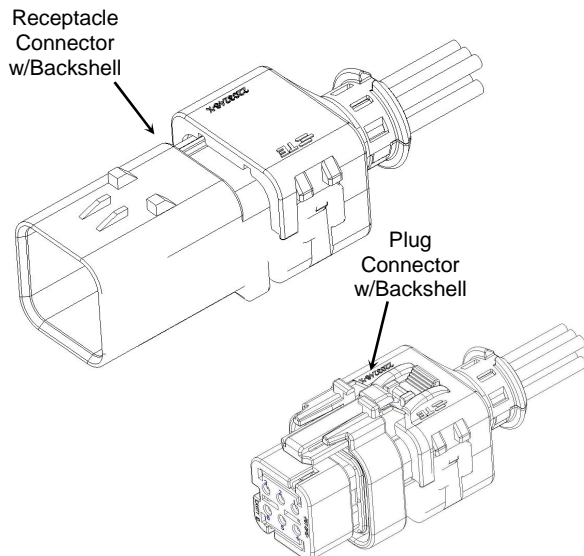

Figure 5

- For additional strength, a wire tie may be applied at the wire exit. Figure 6 shows the wire tie wrapped around the circumference of the wire exit, clamping the two halves of the backshell together.

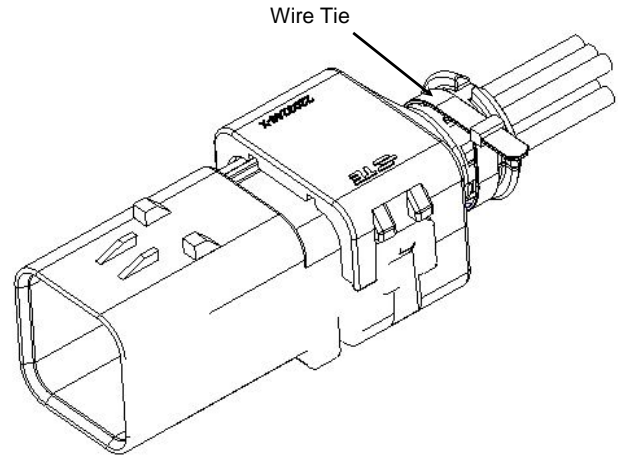

Figure 6

If desired, the wire harness can be secured to one side of the smooth exit backshell by feeding a wire tie through one of the slots in the wire exit, around the harness, and back out the other slot, shown in Figure 7.

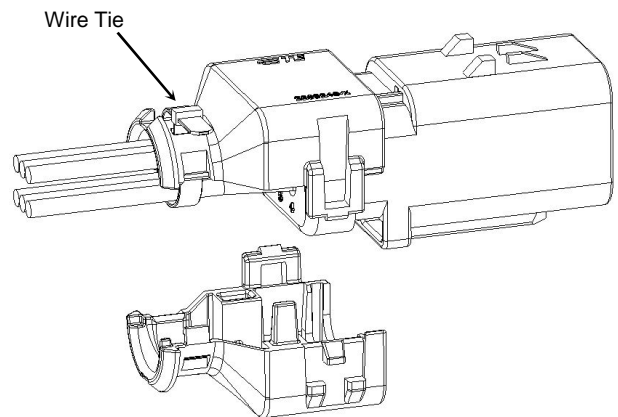

Figure 7

- Heat shrink tubing may also be used with the smooth exit (-1) Vertical and Right

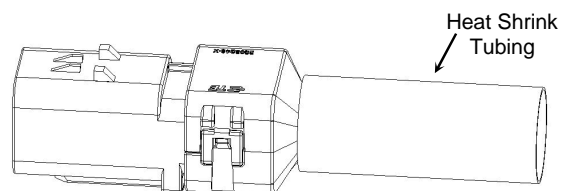

Figure 8

Angle backshells. Slide the tubing around the wire exit, as shown in Figure 8, ensuring it covers the back lip.

Then, heat the tubing per the manufacturer's directions, so the tubing fits snugly around the wire exit and wires. See Figure 9 for the finished result.

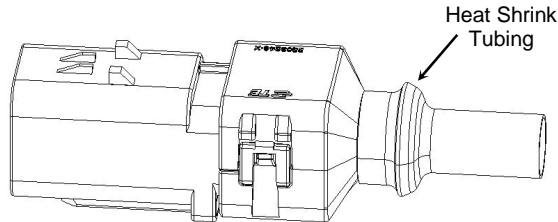

Figure 9

B. CONDUIT APPLICATIONS

Note: Vertical and Right Angle Backshells with a designation of -2 and -3 accept conduit. Refer to Table 2 for the applicable normal profile conduit sizes.

1. Terminate the contacts according to the instructions provided with the specific termination tooling.
2. String terminated wire through the conduit.
3. Load connector with the terminated wires.
4. Align the plug or receptacle connector and the bottom half of the backshell as shown in Figure 10.

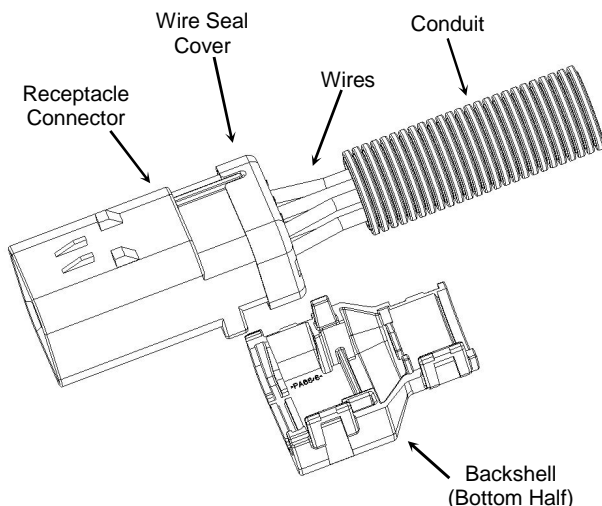

Figure 10

5. Insert the connector into the bottom half of the backshell, so that the wire seal cover is behind the second rib at the opening of the backshell. The conduit should be placed into the wire exit portion of the backshell with the end at or near the conduit flange and the conduit retention rib recessed within one of the wells of the conduit as shown in Figure 11.

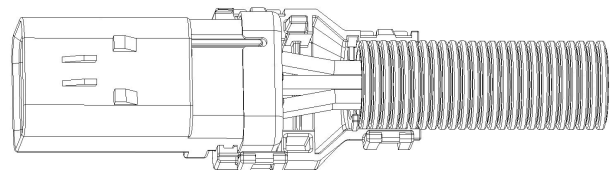

Figure 11

6. For assembly to a receptacle connector, turn the top half of the backshell over. Again, insert the connector into the backshell so that the wire seal cover is behind the second rib at the opening of the backshell and the conduit retention rib is in a well of the conduit. Firmly press the two halves together. An audible and tactile click will indicate when they are mated. Visually check all the latches for complete engagement. See Figure 12.

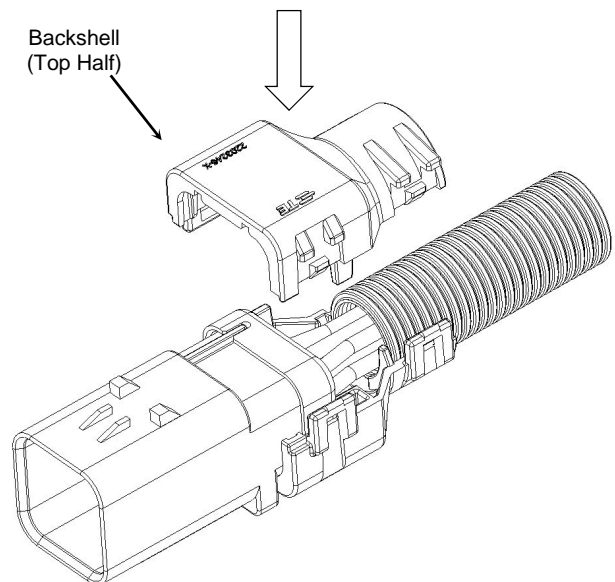

Figure 12

7. For assembly to a plug connector, be sure that the top half is a backshell with an open window area. Again, insert the connector into the backshell so that the wire seal cover is behind the second rib at the

opening of the backshell and the conduit retention rib is in a well of the conduit.

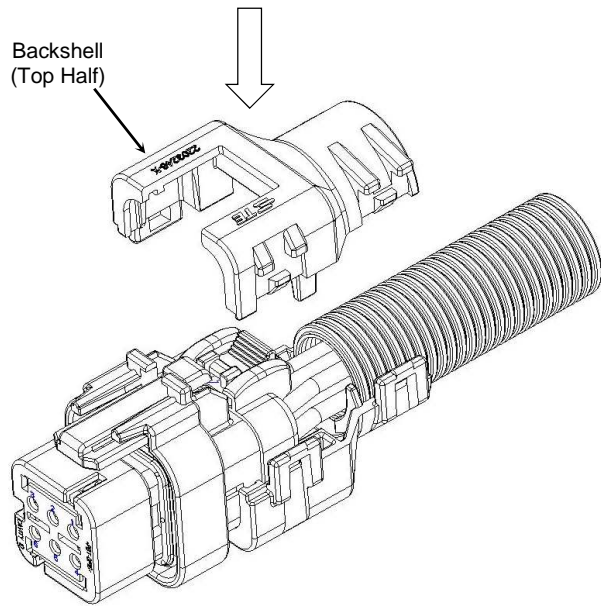

Figure 13

Firmly press the two halves together. An audible and tactile click will indicate when they are mated. Visually check all the latches for complete engagement. See Figure 13.

8. The complete AMPSEAL 16 Backshell with connectors is shown in Figure 14.

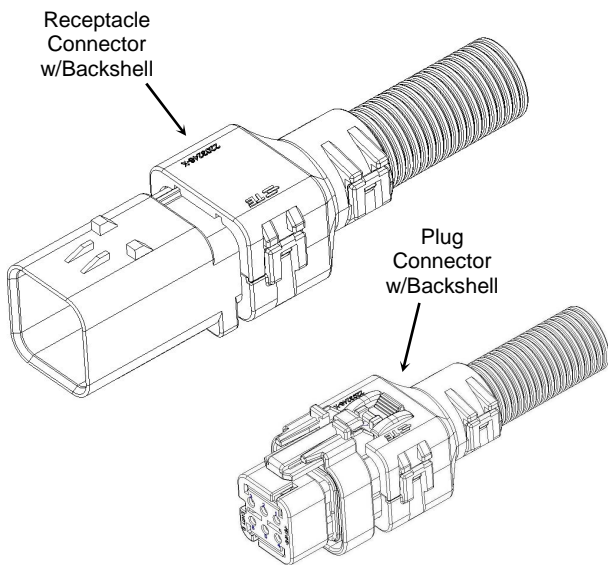

Figure 14

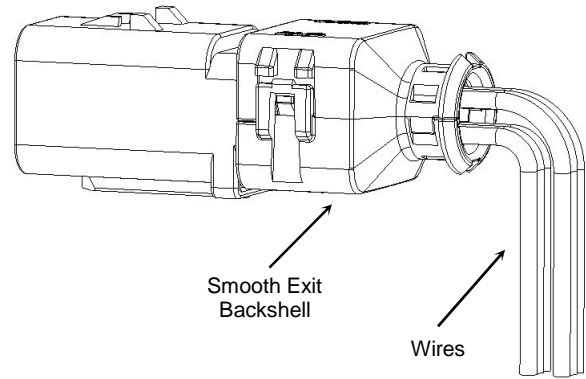

Figure 15

C. RIGHT ANGLE BACKSHELL APPLICATION

Note: Right Angle Backshell Kits come with the backshell and elbow. Elbows are not available separately.

1. Complete steps 1-7 of the smooth exit applications backshell assembly process (section 3.A) and bend the exit wires in the desired direction, as shown in Figure 15.
2. Align the assembled backshell and the first elbow piece as shown in Figure 16.
3. Insert the assembled backshell into the elbow so that the rim of the backshell lies within the open retention slot of the elbow. Ensure that the wires follow the curve of the elbow and exit through the wire exit of the elbow. For conduit applications, the end of the conduit should be placed at or near the conduit flange, with the conduit retention rib recessed within one of the wells of the conduit. Refer to Figure 17.

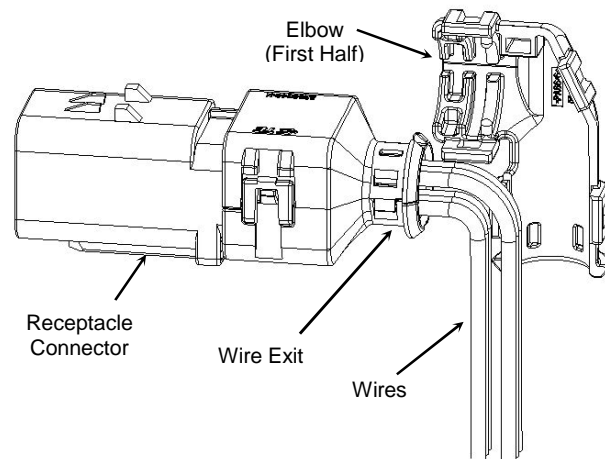

Figure 16

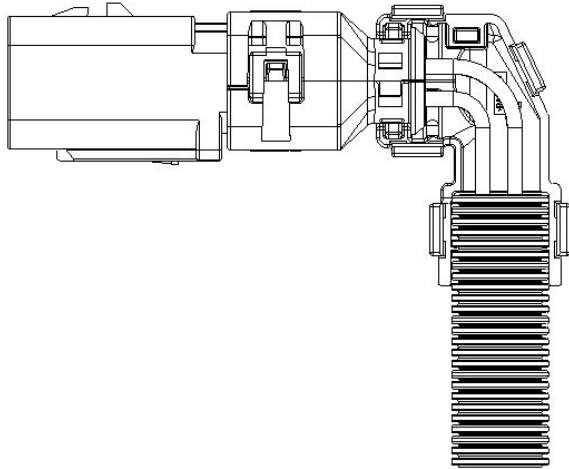

Figure 17

4. Select the opposing elbow piece and again insert the assembled backshell into the

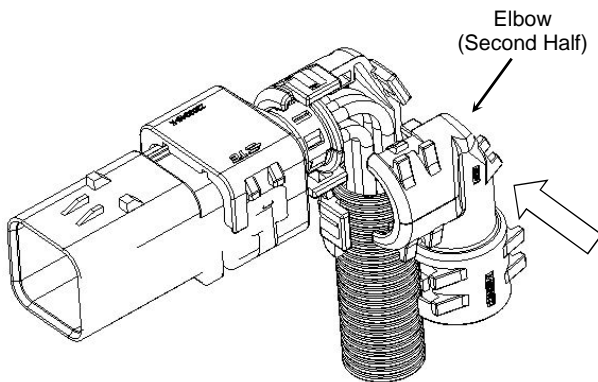

Figure 18

elbow so that the rim of the backshell lies within the open retention slot of the elbow and so the conduit retention rib is in a well of the conduit. Firmly press the two halves together. An audible and tactile click will indicate when they are mated. Visually check all the latches for complete engagement. See Figure 18.

5. The complete AMPSEAL16 Right Angle Backshell assembly is shown in Figure 19.
6. If a smooth exit elbow is used, a wire tie may be applied at the wire exit for additional strength, as is done for the smooth exit backshells in step 8 of section 3.A. The wire tie can be wrapped around the circumference of the wire exit, clamping the two halves of the elbow together, similar to what is shown in Figure 6.

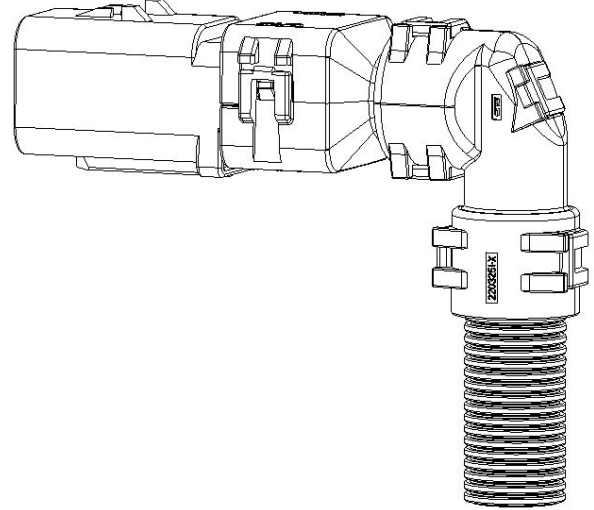

Figure 19

The wire harness can be secured to one side of the elbow by feeding a wire tie through one of the slots in the wire exit, around the harness, and back out the other slot, similar to what is shown in Figure 7.

7. Likewise, heat shrink tubing may be applied to the elbow in the same manner as the backshell, described in step 9 of section 3.A, as well as Figures 8 and 9.

4. REPAIR AND REPLACEMENT

If the backshell, elbow, connector, or contacts become damaged, they must be replaced with new ones. To disassemble the backshell and elbow, first remove any wire ties or heat shrink tubing. Then, using a small flat-head screwdriver, pry out both sets of latch features and remove the two halves. See Figure 20. Once the repairs are

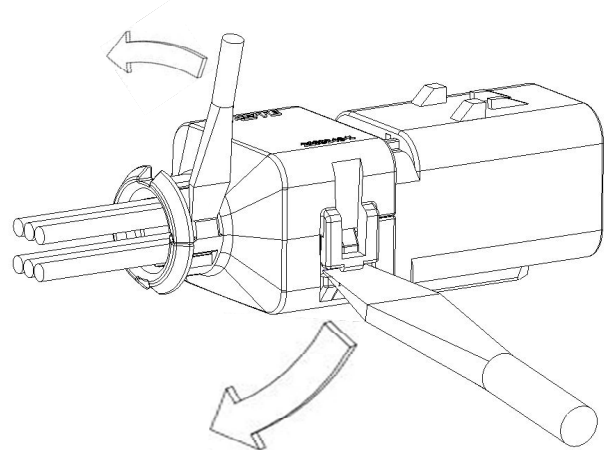

Figure 20

complete, re-assemble the backshell or elbow using the preceding procedures.

5. REVISION SUMMARY

Rev	Description	Date
1	Initial draft of document.	07/28/2015
2	Added elbow instructions	08/14/2015
3	Changes for RA Backshells	07/20/2016
4	Final Review	07/25/2016
A	Released	07/27/2016