

© 1962 BY AMP INCORPORATED. ALL RIGHTS RESERVED. AMP PRODUCTS COVERED BY PATENTS AND/OR PATENTS PENDING.

REVISIONS				
ZONE	LTR	DESCRIPTION	DATE	APPROVED
A		REMOVED MIL-SPEC FROM GOLD PL. FC-5213	11/11/66	RHW

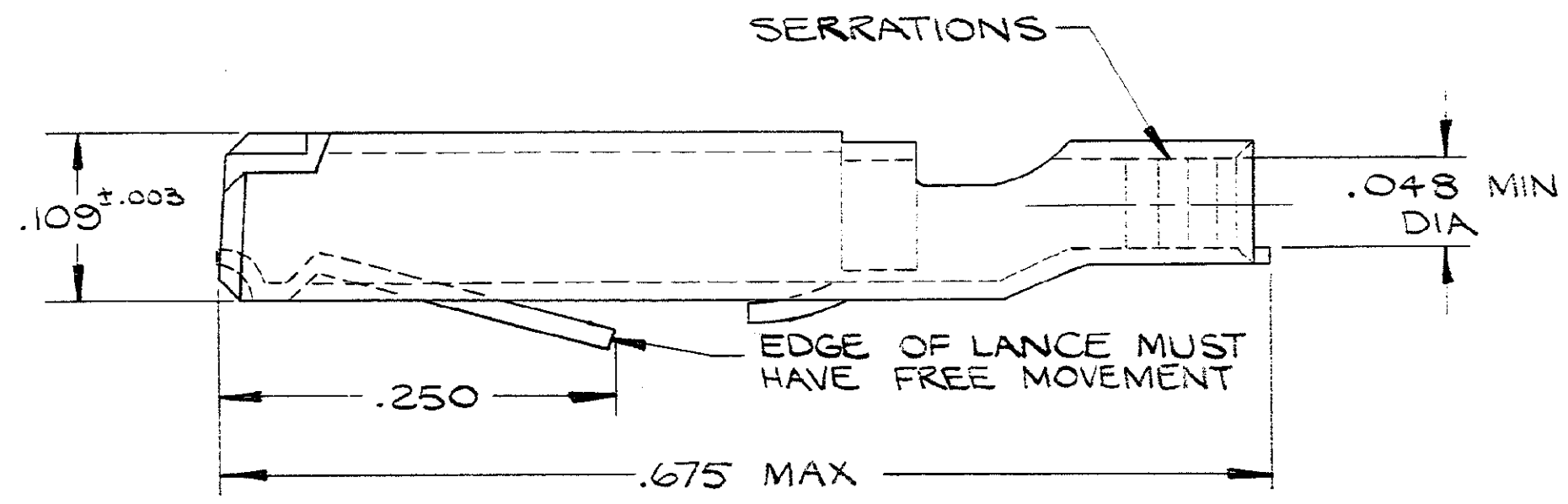
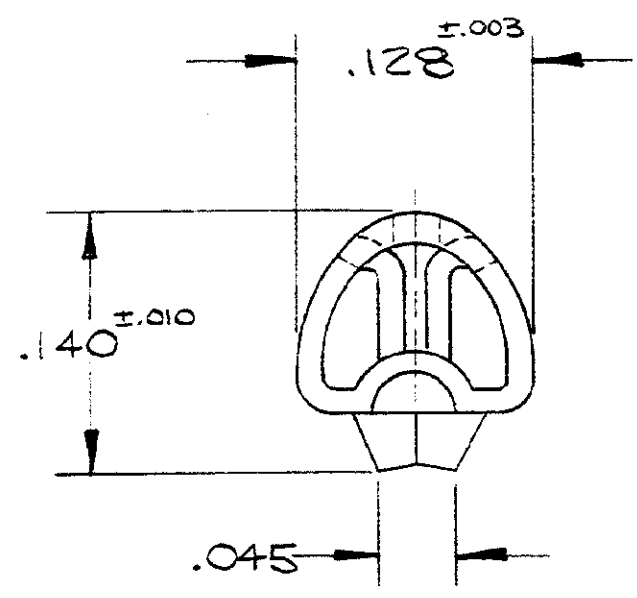

NOTES:

- GOLD PLATED .00002 MIN EXT THK OVER NICKEL PLATED (QQ-N-290) .00005 MIN EXT THK

UNLESS OTHERWISE SPECIFIED DIM. ARE IN INCHES. TOLERANCES ON: DECIMALS ± .003 ANGLES ± 5°		CONTRACT NO. _____		AMP INCORPORATED HARRISBURG, PENNSYLVANIA	
MATERIAL BRASS (MIL-C-50) .012 THK		DR. <i>R. Ketchum</i> 9-27-66		NAME LANCELOK BUDGET	
LOC G141A		CHK. <i>R. Wolfe</i> 9/27/66		WIRE SIZE: 24-22	
PRINT DIST. _____		APPD. <i>Lucas</i> 9-27-66		NUMBER 329531	
HEAT TREAT _____		DSGN APPD. _____		SCALE 10-1	
FINISH NOTE-1		OTHER APPD. _____		WT CALC ACTUAL SHEET 1 OF 1	