

4

3

2

1

THIS DRAWING IS UNPUBLISHED. RELEASED FOR PUBLICATION, 19 .

© COPYRIGHT 19 BY AMP INCORPORATED. ALL RIGHTS RESERVED.

LOC	DIST	REVISIONS					
		P	LTR	DESCRIPTION	DATE	DWN	APVD
G	14			ADDED -2 PER 0G3A-0273-00	22MAY00	JR	MS

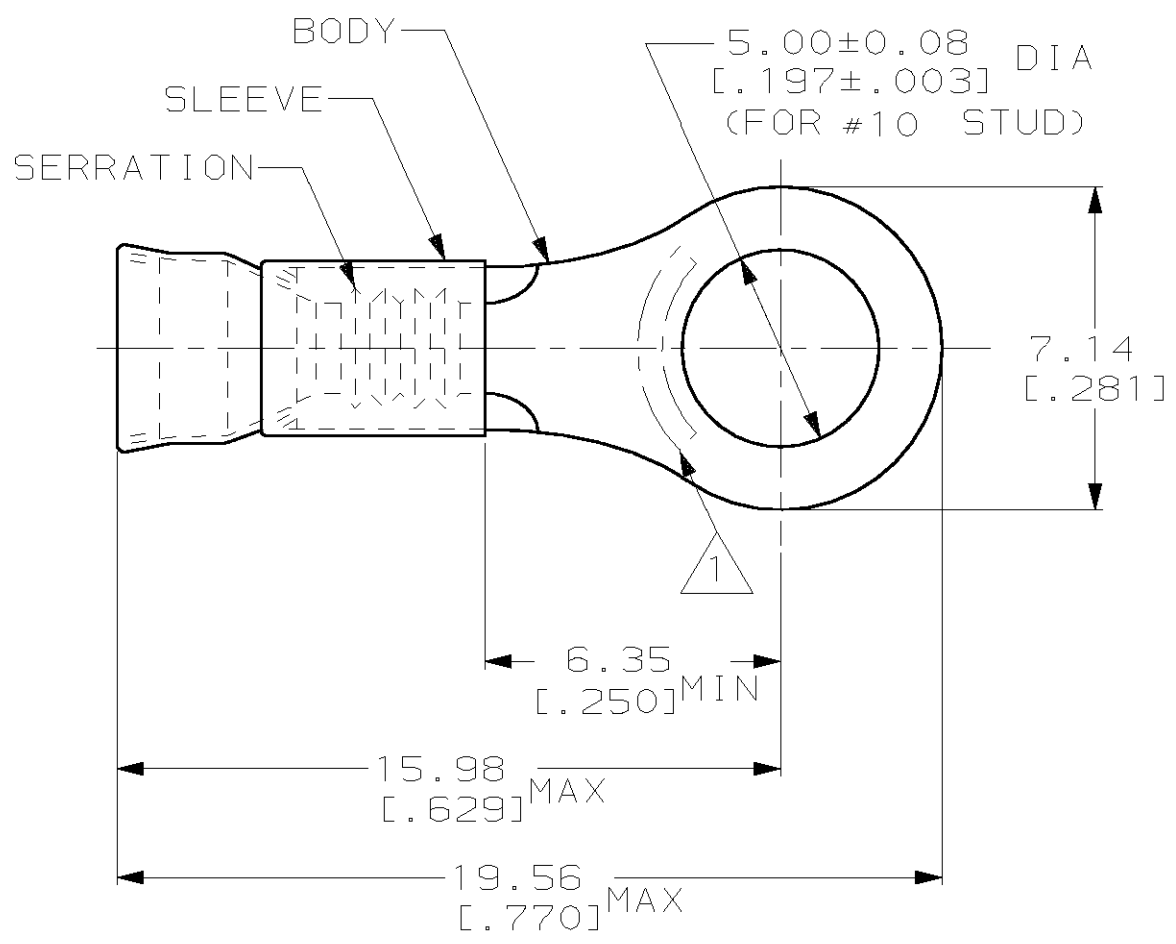

- ① STAMP AMP 22-18*APPROX AS SHOWN
22-16 TERMINALS ARE STAMPED 22-18 IN ACCORDANCE WITH MILITARY SPEC MIL-T-7928 COMMERCIAL WIRE RANGE IS 22-16
- 2. WIRE INSUL DIA, 1.30-2.79 [.051-.110]
- 3. TONGUE MATL THK, 0.79±0.05 [.031±.002]
- ④ NICKEL PL PER QQ-N-290
- ⑤ GOLD PL PER MIL-G-45204 OVER NICKEL PL PER QQ-N-290
- ⑥ PRELIMINARY - NOT FOR PRODUCTION

QTY	PACKAGE TYPE	PART NO
5000	ON TAPE, REEL	④ 323153-2
1000	LOOSE PIECE	④ 323153-1
1000	LOOSE PIECE	④ 323153

AMP INCORPORATED CUSTOMER SERVICE SYSTEM		MAX RECOMMENDED OPERATING TEMPERATURE: 343°C [650°F]	THIS DRAWING IS A CONTROLLED DOCUMENT FOR AMP INCORPORATED. IT IS SUBJECT TO CHANGE AND THE CONTROLLING ENGINEERING ORGANIZATION SHOULD BE CONTACTED FOR THE LATEST REVISION.		DWN L OLMEDA 100CT94	AMP Incorporated Harrisburg, PA 17105-3608
FOR ADDITIONAL PRODUCT INFORMATION OR COPIES OF DRAWINGS AND TECHNICAL DOCUMENTS	PRODUCT INFORMATION CENTER 1-800-522-6752		VOLTAGE RATING: -	DIMENSIONS: mm [in]	TOLERANCES UNLESS OTHERWISE SPECIFIED: 0 PLC ±- 1 PLC ±- 2 PLC ±0.20 [.008] 3 PLC ±- 4 PLC ±- ANGLES ±-	
FOR APPLICATION TOOLING INFORMATION	TOOLING ASSISTANCE CENTER 1-800-722-1111	CIRCULAR MIL AREA: 0.26mm ² -1.65mm ² [509-3260]	MATERIAL BODY, CU PER ASTM B152 SLEEVE, NI SIL PER ASTM B122	FINISH SEE TABLE	APVD S BORTNER 100CT94	PRODUCT SPEC -
FOR ORDER ENTRY	1-800-526-5142	STRANDED WIRE			APPLICATION SPEC -	WEIGHT -
AMP 1470-19 REV 09MAY94				CUSTOMER DRAWING		SIZE: A3 CAGE CODE: 00779 DRAWING NO: C-323153 SCALE: 6:1 SHEET: 1 OF 1 REV: G