

THIS DRAWING IS UNPUBLISHED.
DIFFUSION RESTREINTE

RELEASED FOR PUBLICATION
LIBRE A LA DIFFUSION

2011

LOC - DIST

REVISIONS

© COPYRIGHT 2011 by Tyco Electronics Corporation

ALL RIGHTS RESERVED.
TOUS DROITS RESERVES

P	LTR REV	DESCRIPTION MODIFICATIONS	DATE	DWN DESS	APVD APPR
	A	CREATION	27-May-15	BH	-

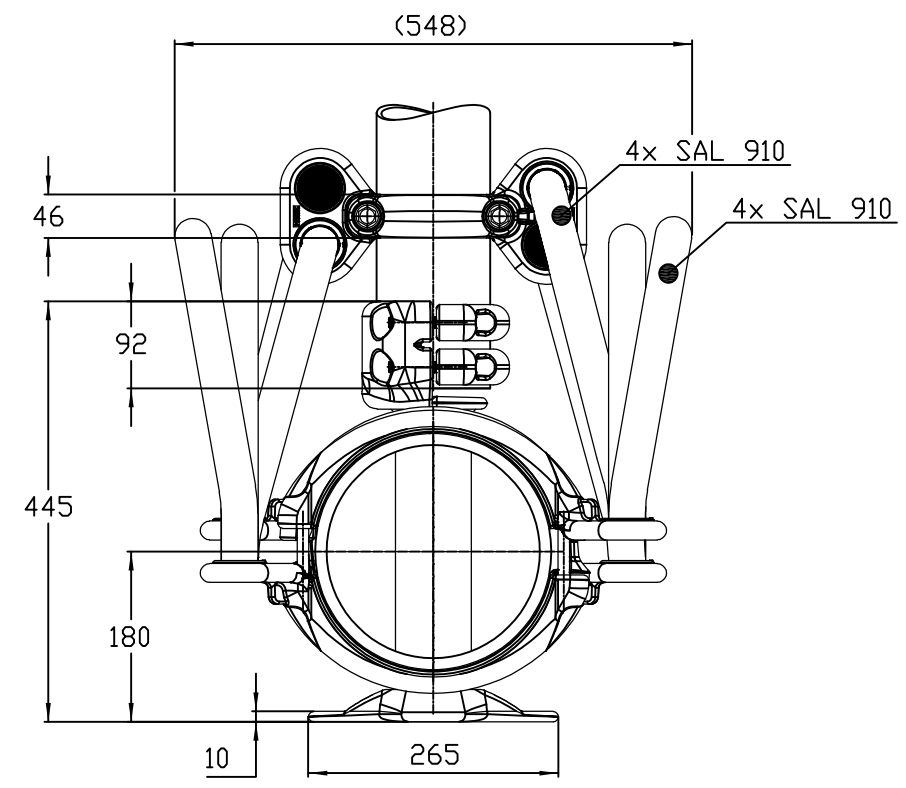
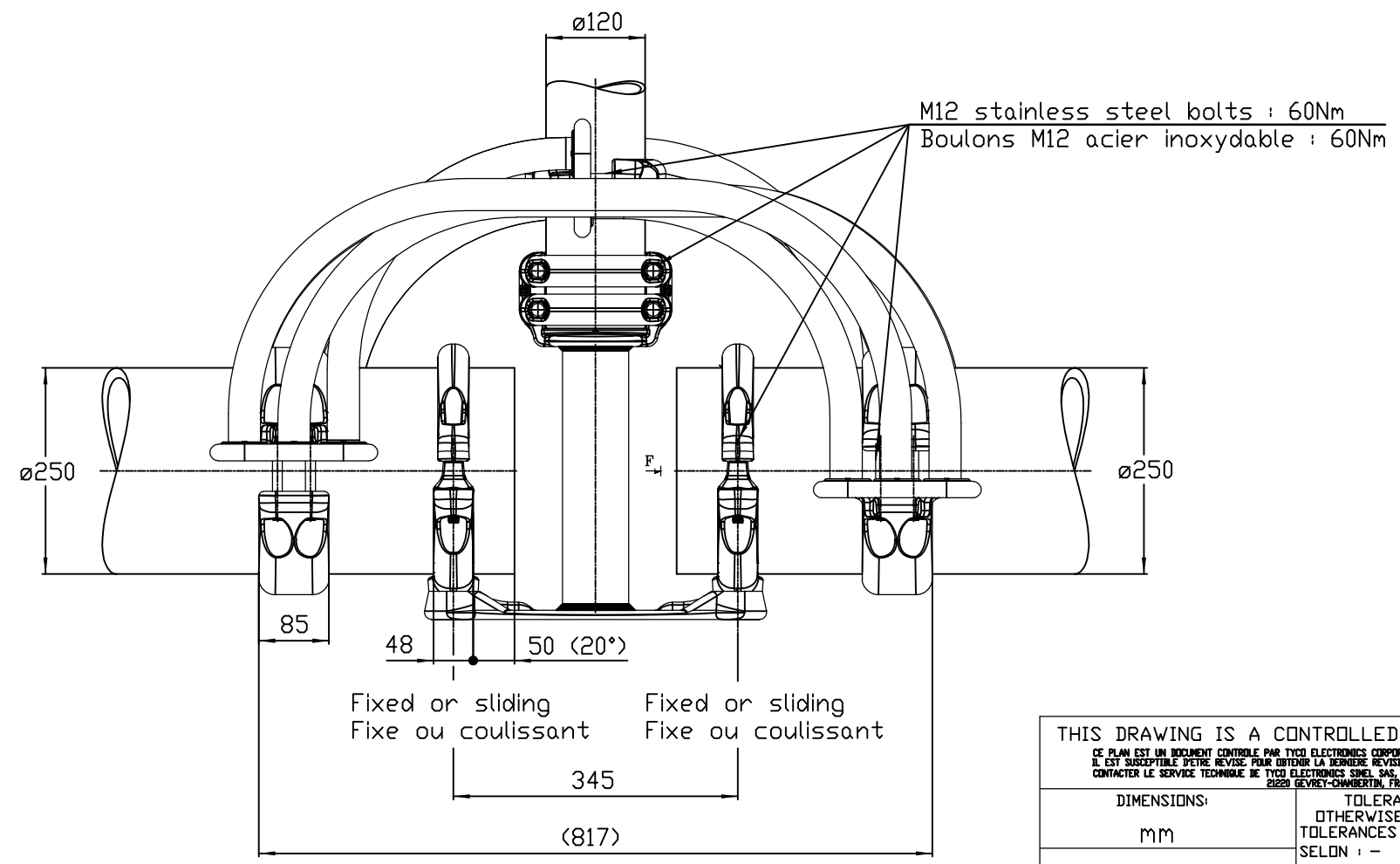
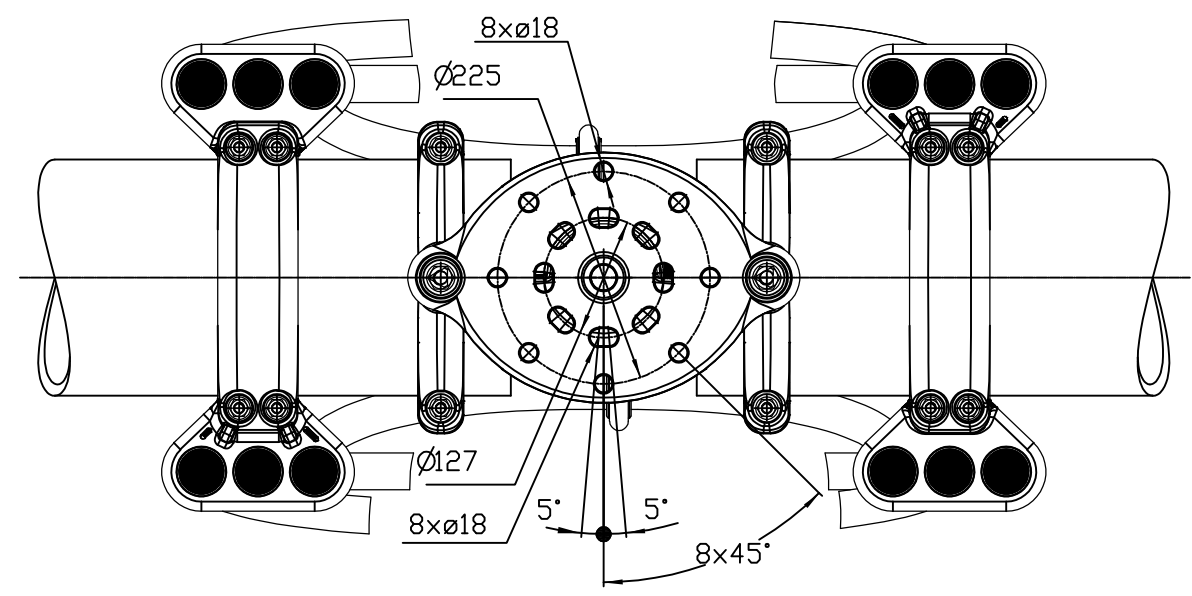
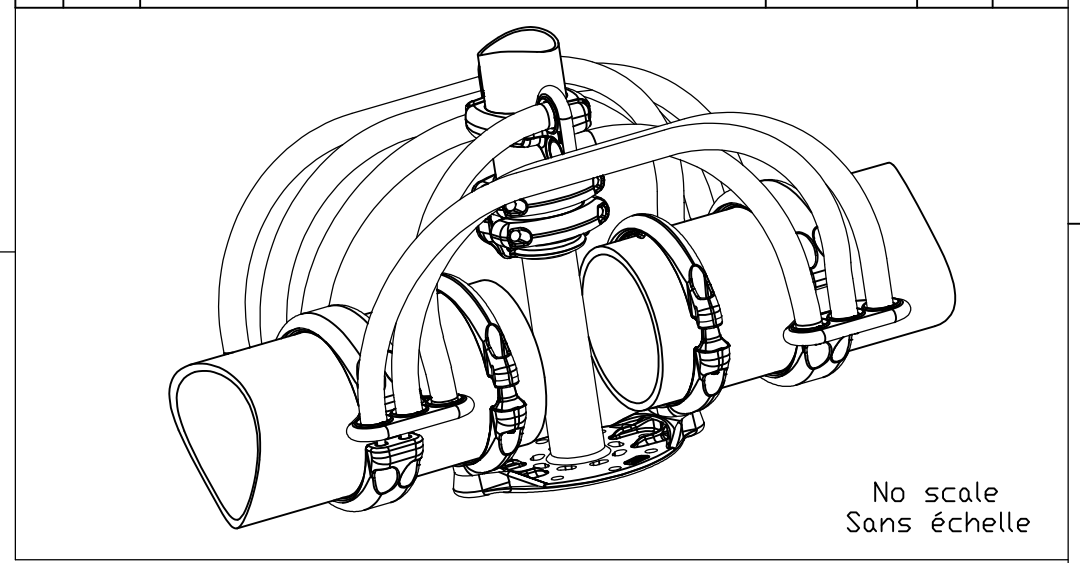
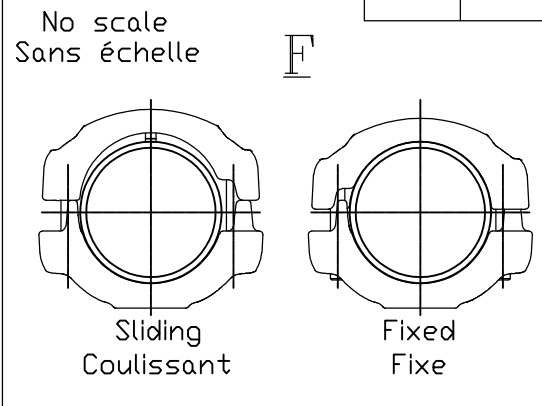

THIS DRAWING IS A CONTROLLED DOCUMENT. CE PLAN EST UN DOCUMENT CONTRÔLÉ PAR TYCO ELECTRONICS CORPORATION IL EST SUSCEPTIBLE D'ÊTRE RÉVISÉ. POUR OBTENIR LA DERNIÈRE RÉVISION, CONTACTER LE SERVICE TECHNIQUE DE TYCO ELECTRONICS SIMEL SAS, 21220 GEVREY-CHAMBERTIN, FRANCE.		DWN /DESSINE HUARD	27-May-15	TE connectivity SIMEL PRODUCTS	
DIMENSIONS: mm		CHK/VERIFIE	-		
TOLERANCES UNLESS OTHERWISE SPECIFIED PER TOLERANCES NON SPECIFIEES SELON : -		APVD/APPROUVE	-	NAME TITRE JUNCTION - DERIVATION BUS SUPPORT SUPPORT DE JONCTION ET DERIVATION 5 TDJL 82 P5-P225 TR250 T120 49	
MATERIAL MATIERE		PRODUCT SPEC SPEC. PRODUIT	108-69090-001	SIZE FORMAT A3	CAGE CODE 00779
FINISH FINITION		APPLICATION SPEC SPEC. APPLICATION	-	DRAWING NO No PLAN C-2845266	RESTRICTED TO RESERVE A -
WEIGHT MASSE APPROX.		43 kg	CUSTOMER DRAWING /PLAN CLIENT		
UNIQUEMENT POUR REFERENCE		SCALE ECHELLE	1/8	SHEET FEUILLE	1 OF 1 DE 1
REV		A			

ITEM:.....