

| ATLANTIC VERSION TERMINATOR INTERFACE ADAPTER | PART NUMBER | REVISION | DESCRIPTION | FEED TYPE | APPLICATOR STYLE CONVERSION CHART | | | | | | |
|---|-------------|--------------------------|--------------------------------|--------------------------------|-----------------------------------|-----------------------|-----------|-------------|-----------|-----------|------------------------|
| | | | | | CONVERT TO | PART NUMBERS REQUIRED | | | | | |
| | | | | | | | | | | | |
| | 2836188-1 | A | FINE CRIMP HEIGHT ADJUST | MECHANICAL | PNEUMATIC FEED | 2119950-1 | 1338685-1 | 5-18022-5 | 2119641-1 | 2119799-1 | 2063440-1 |
| | | | | | SERVO LATCH PLATE | 2119951-1 | - | 8-2836188-5 | 1901094-3 | - | 2168400-6 (QUANTITY 2) |
| | | | | | SMART APPLICATOR | 2161326-1 | - | 8-2836188-4 | - | - | - |
| | 2836188-2 | A | FINE CRIMP HEIGHT ADJUST | PNEUMATIC | MECHANICAL FEED | 2119949-1 | 1338685-1 | 5-18022-5 | 2119653-1 | - | - |
| | | | | | SERVO LATCH PLATE | 2119951-1 | - | 8-2836188-5 | 1901094-3 | - | 2168400-6 (QUANTITY 2) |
| | | | | | SMART APPLICATOR | 2161326-1 | - | 8-2836188-4 | - | - | - |
| | 2836188-5 | A | FINE CRIMP HEIGHT ADJUST | SERVO LATCH PLATE ⁴ | MECHANICAL FEED | 2119949-1 | 1338685-1 | 5-18022-5 | 2119653-1 | - | - |
| PNEUMATIC FEED | | | | | 2119950-1 | 1338685-1 | 5-18022-5 | 2119641-1 | 2119799-1 | 2063440-1 | |
| 2836188-6 | A | NON-CRIMP HEIGHT ADJUST | SERVO LATCH PLATE ⁴ | - | - | - | - | - | - | - | |
| 2836188-7 | A | FINE CRIMP HEIGHT ADJUST | NONE | - | - | - | - | - | - | - | |
| 7-2836188-7 | A | CRIMP TOOLING KIT | - | - | - | - | - | - | - | - | |

| APPLICATOR DATA | | |
|-----------------|----------------|------|
| CRIMP | SIZE | TYPE |
| WIRE | 1.55 mm [.061] | F |
| INSUL | 2.20 mm [.087] | O |

APPLICATOR INSTRUCTIONS 408-10389

| TERMINAL DATA: MFG TERMINAL | | FCI CRIMP SPECIFICATION | |
|------------------------------------|------------------------|-----------------------------|---------------------|
| TERMINAL NAME: TERMINAL, SOCKET | | | |
| WIRE STRIP LENGTH | | INSULATION DIAMETER RANGE | |
| 4.33-5.09 mm [1.70-.200 IN] | | 1.40-1.90 mm [.055-.075 IN] | |
| TERMINAL APPLICATION SPECIFICATION | PC260CC2SXXX0 Rev N | | |
| TERMINALS APPLIED | | | |
| TE TERMINAL | MFG TERMINAL | TE TERMINAL | MFG TERMINAL |
| 2113954-1 | PP10000590(FCI/DELPHI) | 2113954-2 | 243467448R(RENAULT) |
| 2113954-3 | 47059453/2(IMDS) | 2113954-4 | F156000(FCI/DELPHI) |
| 2113954-5 | 243461905R(RENAULT) | 2113954-6 | 904017901(IMDS) |

| WIRE SIZE | CRIMP HEIGHT mm [INCH] | CRIMP HEIGHT REFERENCE SETTING |
|---------------------|--------------------------------|--------------------------------|
| 0.75mm ² | 1.20 +/- 0.04 [1.047 +/- .002] | 7.8 |
| 0.50mm ² | 1.09 +/- 0.04 [1.043 +/- .002] | 9.0 |

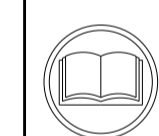

- ¹ RECOMMENDED SPARE PARTS
- ² GREASE BEARING SURFACES LIGHTLY
- 3. LUBRICATE DAILY PER THE APPLICATOR INSTRUCTION SHEET SUPPLIED WITH THE APPLICATOR.
- ⁴ APPLICATOR SPECIFIC DATA TO BE ENTERED INTO BLANK MEMORY CHIP AT ASSEMBLY. SEE BELOW FOR PART NUMBER:
 MECHANICAL FEED WITH "SMART APPLICATOR" CONVERSION: 8-2836188-4
 PNEUMATIC FEED WITH "SMART APPLICATOR" CONVERSION: 8-2836188-4
 SERVO FEED WITH "FINE CRIMP HEIGHT ADJUST": 8-2836188-5
 SERVO FEED WITH "NON-CRIMP HEIGHT ADJUST": 8-2836188-6
- 5. ADJUSTMENT OF THE STRIPPER MAY BE REQUIRED WHEN MOVING THE APPLICATOR BETWEEN BENCH AND LEADMAKER APPLICATIONS.
- ⁶ APPLY PART NUMBER 1-23419-5 LOCTITE TO THREADS OF ITEM 62. APPLY PART NUMBER 2-23419-6 LOCTITE TO THREADS OF ITEM 242. FOR -6 ONLY APPLY PART NUMBER 1-23419-5 LOCTITE TO THREADS OF ITEM 37.
- ⁷ GREASE THREADS, GROOVE AND O-RING ON ITEMS 35 & 252.
- ⁸ MAGNET, ITEM 166 MUST BE ORIENTED CORRECTLY IN ORDER TO PROPERLY ACTUATE THE COUNTER.
- ⁹ CRIMP HEIGHT REFERENCE SETTING WAS THE SETTING USED WHEN THE APPLICATOR WAS QUALIFIED AT THE FACTORY. ADJUSTMENT MAY BE NECESSARY WHEN RUNNING APPLICATOR IN THE FIELD.
- ¹⁰ SPARE FEED CAM STORAGE LOCATION REFER TO INSTRUCTION SHEET FOR ADDITIONAL INFORMATION.
- ¹¹ TO CONVERT THE APPLICATOR TO A NON-CARRIER CUTTING STYLE, REMOVE ITEM 13 AND ATTACH TO THE LOCATION ON THE BACK SIDE OF THE HOUSING. REFER TO INSTRUCTION SHEET FOR ADDITIONAL INFORMATION.
- ¹² WHEN ASSEMBLING A NON CRIMP HEIGHT ADJUST APPLICATOR (-6) USE SHIMS FROM ITEM 260 TO ACHIEVE A NOMINAL SHIM HEIGHT OF 4.6.

***WARNING**
 ON INSTALLATION, SET WIRE DISC, ITEM 40 TO LARGEST WIRE SIZE SETTING. USE OF SETTINGS BELOW MINIMUM REQUIRED CRIMP HEIGHT SETTING WILL CAUSE DAMAGE TO CRIMP TOOLING.

| -77 | -7 | -6 | -5 | -2 | -1 | PART NO | DESCRIPTION | ITEM NO |
|-----|----|----|----|----|----|-----------|----------------------|---------|
| - | - | 1 | - | - | - | 2119957-2 | APPLICATOR SHIM PACK | 260 |

ATLANTIC VERSION
 Shown on sheets 1 of 4 & 2 of 4
 (Pacific version shown on sheets 3 of 4 & 4 of 4)

| SET UP GAUGE | LOC | DIST | REVISIONS | | | | | |
|--------------|-----|------|-----------|-----|-------------|-----------|-----|------|
| 2119599-1 | A | 66 | # | LTN | DESCRIPTION | DATE | OWN | APVD |
| | | | 1 | | DEVELOPMENT | 23FEB2016 | JH | UG |
| | | | A | | RELEASED | 05APR2016 | JH | TE |

| | | | | | | | | |
|---|-----|-----|-----|-----|-----|--------------|-------------------------------------|-----|
| - | 1 | - | 1 | 1 | 1 | 8-21084-0 | O-RING, .676 ID, .070 DIA. MAT. | 252 |
| - | - | - | - | 1 | - | 2119640-1 | PUSH ROD, AIR FEED | 250 |
| - | - | - | - | 1 | - | 2079988-1 | BUSHING, LCH5-12, MISUMI | 249 |
| - | - | - | - | 1 | - | 2119641-1 | FEED CAM, AIR FEED | 248 |
| - | 1 | - | 1 | 1 | 1 | 2119798-1 | DETENT PIN | 247 |
| - | 1 | - | 1 | 1 | 1 | 1-22279-3 | SPRING, COMPRESSION | 246 |
| - | - | 1 | - | - | - | 2119758-1 | RAM, AMP STYLE, SIDE FEED, NON-ADJ. | 245 |
| - | 1 | 1 | 1 | 1 | 1 | 2119082-1 | CAM, SNAIL, INSULATION ADJUSTMENT | 244 |
| - | 1 | 1 | 1 | 1 | 1 | 2079764-1 | WASHER, WAVE SPRING, CREST-TO-CREST | 243 |
| - | 1 | 1 | 1 | 1 | 1 | 2119083-1 | RETAINER, INSULATION DIAL | 242 |
| - | 1 | 1 | 1 | 1 | 1 | 7-18023-7 | SCR, SKT HD CAP M3 X 4.0 | 241 |
| - | - | 2 | 2 | - | - | 2168400-6 | SHCS, LOW HEAD, RoHS, M5 X 16 | 240 |
| - | - | - | - | - | 1 | 2119580-1 | MECHANICAL FEED ASSEMBLY | 239 |
| - | - | - | - | - | 1 | 2063440-1 | AIR FEED MODULE | 238 |
| - | - | 1 | 1 | - | - | 2119740-2 | TAG, IDENTIFICATION | 213 |
| - | - | 1 | 1 | - | - | 1901094-3 | SPACER, FEEDER | 198 |
| - | - | - | - | - | 2 | 21045-3 | RING, RETAIN, EXTERN, 3/16 CRESCENT | 172 |
| - | 1 | 1 | 1 | 1 | 1 | 994969-1 | MAGNET, RARE EARTH HIGH ENERGY | 166 |
| - | REF | REF | REF | REF | REF | 994970-2 | COUNTER, MAGNETIC | 164 |
| - | - | - | - | 1 | - | 240638-1 | SPRING, FEED FINGER | 163 |
| - | - | - | - | 1 | - | 3-23627-7 | PIN, RETAIN, GRVD, 3/16 X .854 | 137 |
| - | - | - | - | 1 | - | 2119799-1 | HOLDER, FEED FINGER, AF | 136 |
| - | - | REF | REF | - | - | SEE NOTE 4 | MEMORY CHIP, PROGRAMMED | 135 |
| - | - | 1 | 1 | - | - | 1633743-1 | SERVO FEED LATCH ASM | 133 |
| - | - | REF | REF | - | - | 2119944-1 | FEED FINGER ASSEMBLY, SF | 117 |
| - | 1 | 1 | 1 | 1 | 1 | 455888-6 | SPACER, CRIMPER | 82 |
| - | 1 | 1 | 1 | 1 | 1 | 2119956-1 | DOCUMENTATION PACKAGE | 71 |
| - | 1 | - | - | 1 | 1 | 2119740-1 | TAG, IDENTIFICATION | 67 |
| - | 2 | 2 | 2 | 2 | 2 | 2168078-1 | SCREW, DRIVE, RH, RoHS, 2 x .188 | 66 |
| - | 1 | - | 1 | 1 | 1 | 2119793-1 | LIMITER, ADJUSTMENT BOLT | 63 |
| - | 3 | - | 3 | 3 | 3 | 992763-5 | SCR, SET, SOC, CONE POINT, M3 X 4.0 | 62 |
| - | 1 | 1 | 1 | 1 | 1 | 2079383-4 | SCR, BHSC, RoHS (M4 X 8) | 60 |
| - | - | - | - | 1 | 1 | 5-18022-5 | SCR, HEX HD CAP, M4 X 6.0 | 59 |
| - | - | - | - | 1 | 1 | 1338685-1 | PAWL, FEED | 56 |
| - | 4 | 4 | 4 | 4 | 4 | 2168400-1 | SHCS, LOW HEAD, RoHS, M4 X 12 | 54 |
| - | 2 | 2 | 2 | 2 | 2 | 1-21680083-0 | SCR, SKT HD CAP, RoHS, M4 X 10 | 53 |
| - | 1 | 1 | 1 | 1 | 1 | 5018030-1 | NUT, HEX, REG, RoHS, M3 | 52 |
| - | 1 | 1 | 1 | 1 | 1 | 811242-5 | BUMPER, HOLD DOWN | 51 |
| - | 1 | 1 | 1 | 1 | 1 | 690753-2 | SPACER, TONKER | 50 |
| - | - | - | - | 1 | 2 | 18023-9 | SCR, SKT HD CAP M4 X 6.0 | 49 |
| - | - | - | - | - | 1 | 2119652-1 | FEED CAM, PRE FEED | 48 |
| - | - | - | - | - | 1 | 2119653-1 | FEED CAM, POST FEED | 47 |
| - | 1 | 1 | 1 | 1 | 1 | 2119656-9 | APPLICATOR BASIC ASSEMBLY, SF | 46 |
| - | 1 | - | - | 1 | 1 | 2119370-1 | RAM, AMP STYLE, SIDE FEED | 44 |
| - | 1 | 1 | 1 | 1 | 1 | 2079383-7 | SCR, BHSC, RoHS (M8 X 25) | 41 |
| - | 1 | - | - | 1 | 1 | 2119645-1 | DISC, NUMBERED FA WIRE ADJUSTMENT | 40 |
| - | 1 | - | - | 1 | 1 | 2119957-1 | APPLICATOR SHIM PACK | 39 |
| - | 1 | 1 | 1 | 1 | 1 | 1-2119644-2 | RAM WASHER, PRECISION | 38 |
| - | 1 | 1 | 1 | 1 | 1 | 2119085-1 | FA HEAD, ATLANTIC STYLE | 37 |
| - | 1 | - | - | 1 | 1 | 2119092-1 | BOLT, ADJUSTMENT | 35 |
| - | 1 | 1 | 1 | 1 | 1 | 1752356-3 | SUPPORT, TERMINAL | 34 |
| - | 2 | 2 | 2 | 2 | 2 | 2079383-5 | SCR, BHSC, RoHS (M4 X 20) | 33 |
| - | 1 | 1 | 1 | 1 | 1 | 2161328-1 | HEX HEAD, FLANGED, M5 X 8mm LONG | 32 |
| - | 1 | 1 | 1 | 1 | 1 | 1320908-3 | SPACER, STRIP GUIDE | 30 |
| - | 1 | 1 | 1 | 1 | 1 | 2119959-2 | ASSEMBLY, STRIP GUIDE | 29 |
| - | 1 | 1 | 1 | 1 | 1 | 455888-3 | SPACER, CRIMPER | 28 |
| - | 1 | 1 | 1 | 1 | 1 | 1320928-2 | STRIP GUIDE | 24 |
| - | 1 | 1 | 1 | 1 | 1 | 2168083-2 | SCR, SKT HD CAP, RoHS, M4 X 8.0 | 21 |
| - | 2 | 2 | 2 | 2 | 2 | 1-18028-2 | WASHER, FLAT, REG M4 | 20 |
| - | 1 | 1 | 1 | 1 | 1 | 2119533-1 | STRIPPER, SIDE FEED | 19 |
| - | 1 | 1 | 1 | 1 | 1 | 2119806-1 | INSERT, SHEAR | 13 |
| - | 1 | 1 | 1 | 1 | 1 | 3-22280-3 | SPRING, COMPRESSION | 12 |
| - | 1 | 1 | 1 | 1 | 1 | 1-356885-4 | STOP, SHEAR | 11 |
| - | 1 | 1 | 1 | 1 | 1 | 2119805-1 | SHEAR HOLDER, FRONT | 10 |
| - | 1 | 1 | 1 | 1 | 1 | 1803095-1 | FLOATING SHEAR, FRONT | 9 |
| - | 1 | 1 | 1 | 1 | 1 | 7-1803056-9 | ANVIL, COMBINATION | 8 |
| - | - | - | - | - | - | - | - | 7 |
| - | - | - | - | - | - | - | - | 6 |
| - | 1 | 1 | 1 | 1 | 1 | 2119757-4 | DEPRESSOR, SHEAR | 5 |
| - | 1 | 1 | 1 | 1 | 1 | 238011-9 | BLOCK, CRIMPER SPACER | 4 |
| - | 1 | 1 | 1 | 1 | 1 | 1803328-2 | CRIMPER, INSULATION O | 3 |
| - | 1 | 1 | 1 | 1 | 1 | 455888-6 | SPACER, CRIMPER | 2 |
| - | 1 | 1 | 1 | 1 | 1 | 7-1633860-6 | CRIMPER, WIRE | 1 |

| DIMENSIONS: | | TOLERANCES UNLESS OTHERWISE SPECIFIED: | | DWG | | CHK | | APVD | |
|--|---------|--|---------|--------------|---------|---------|---------|----------------|---------|
| mm | 0 PLC ± | 1 PLC ± | 2 PLC ± | 3 PLC ± | 4 PLC ± | 5 PLC ± | 6 PLC ± | 7 PLC ± | 8 PLC ± |
| | ANGLES | FINISH | | MATERIAL | | WEIGHT | | SCALE | |
| Customer Accessible Production Drawing | | SCALE 1:2 | | SHEET 1 OF 4 | | REV A | | DATE 23FEB2016 | |

STE TE Connectivity
 Harrisburg, PA 17105-3608

Ocean Side Feed
 Applicator

SIZE CAGE CODE DRAWING NO
 A1 00779 C=2836188

| LOC | | DIST | | REVISIONS | | | |
|-----|----|------|-----|-------------|------|-----|------|
| A | 66 | P | LTM | DESCRIPTION | DATE | OWN | APVD |
| | | - | - | SEE SHEET 1 | - | - | - |

FEED TYPE MECHANICAL



PNEUMATIC



SERVO LATCH PLATE



CAM POSITIONS

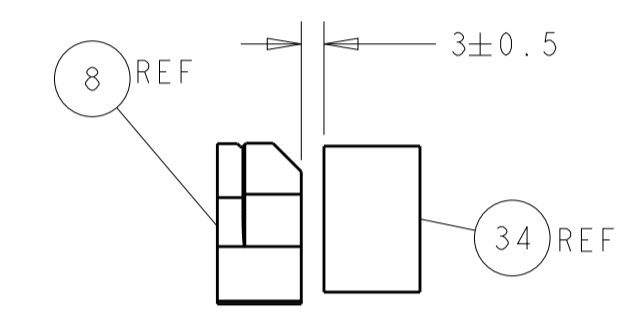
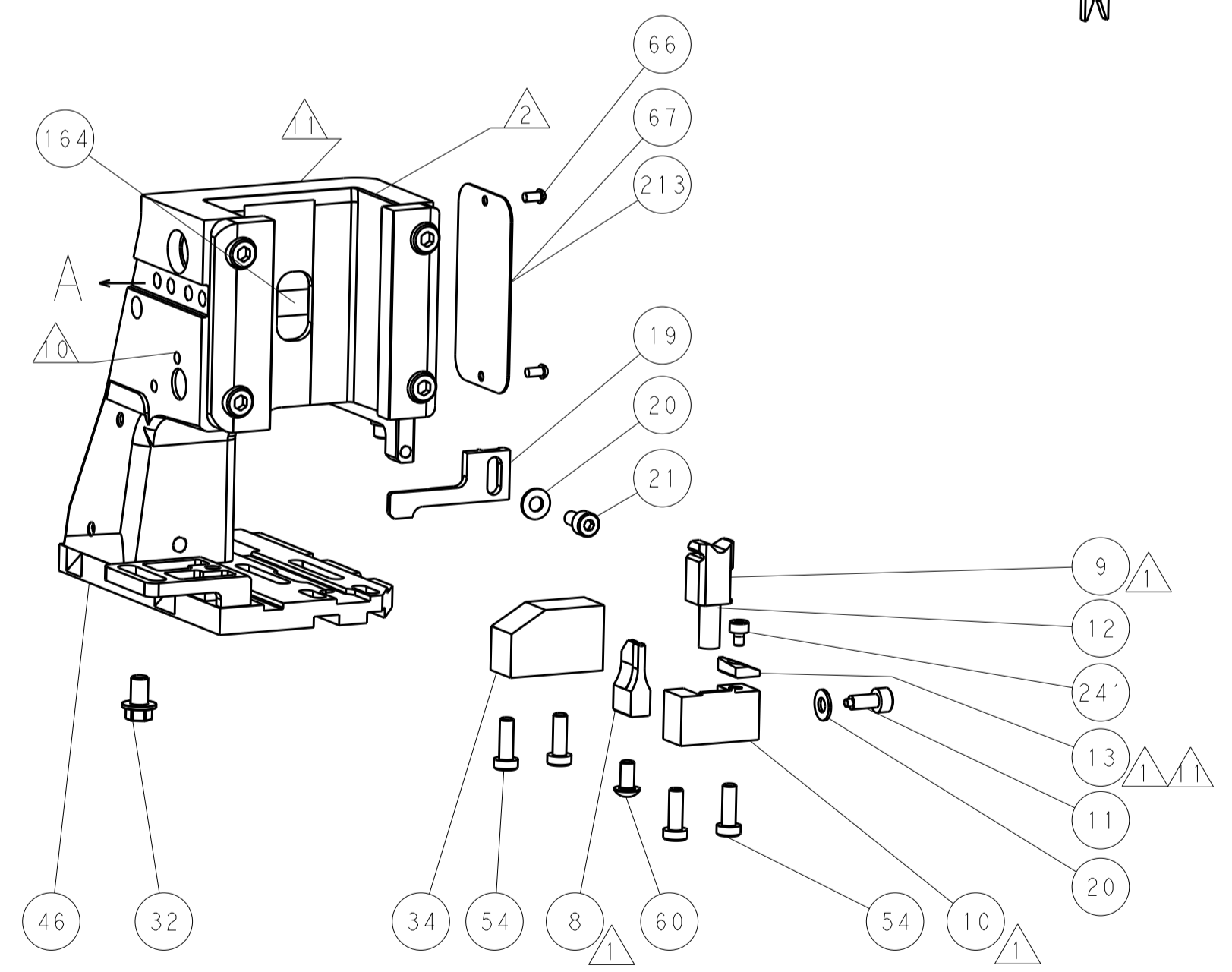
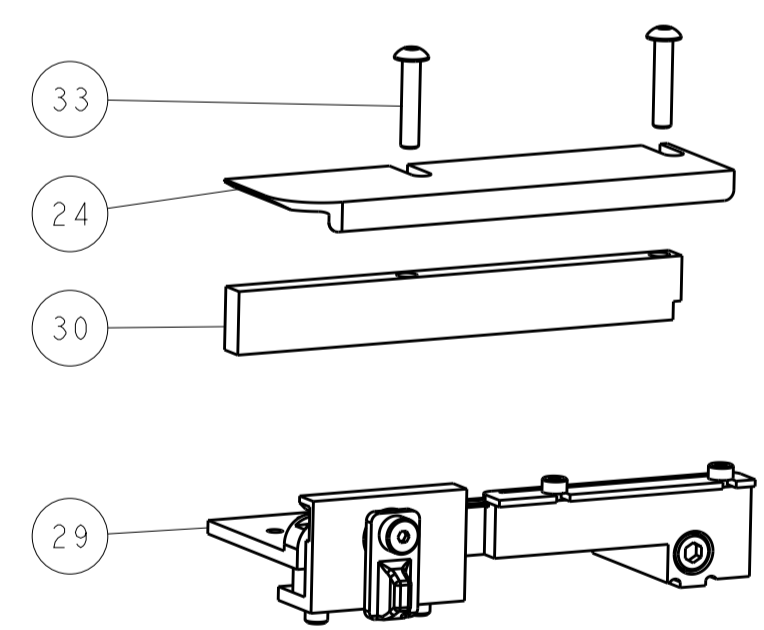
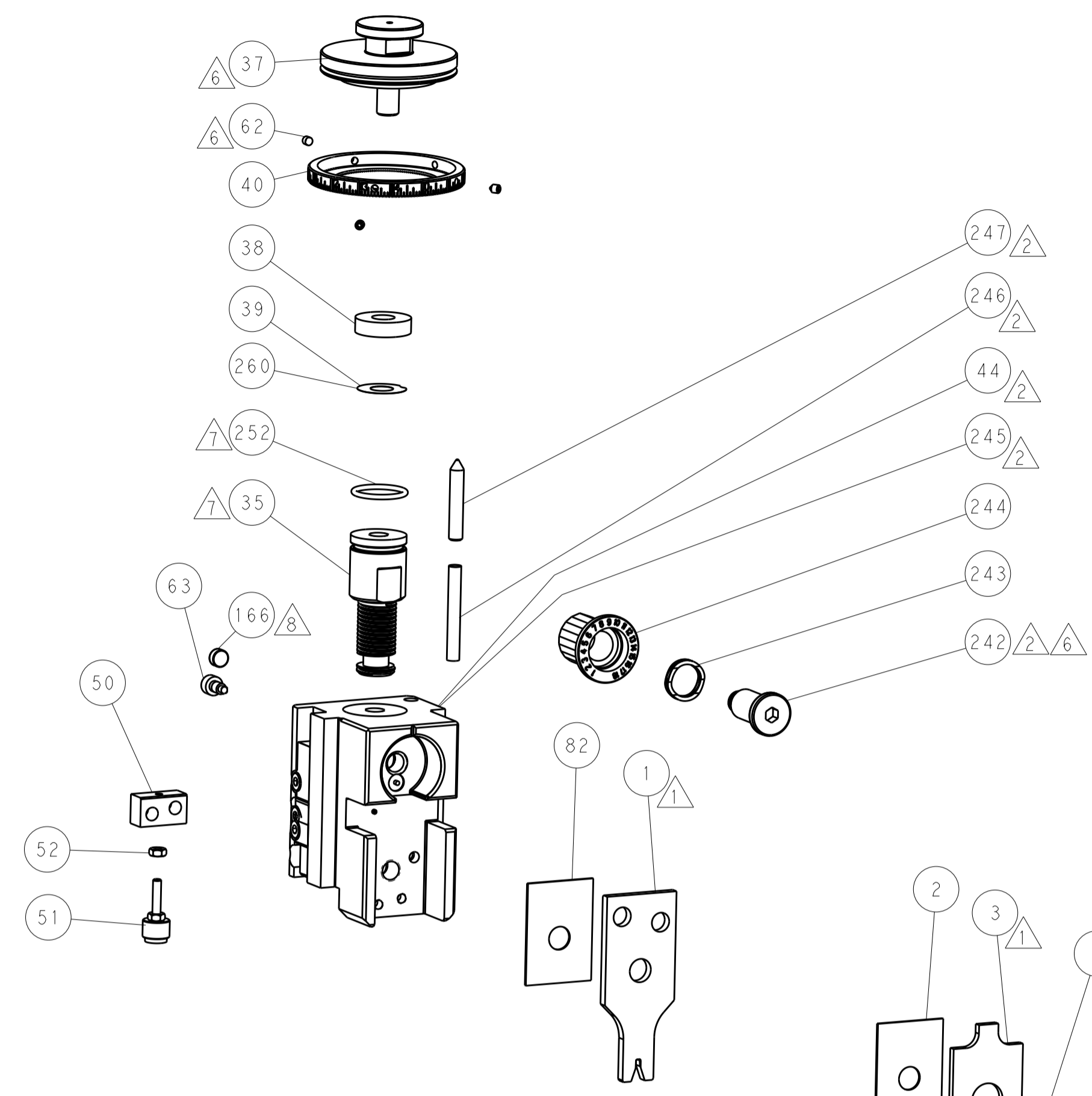

TERMINAL SUPPORT LOCATION

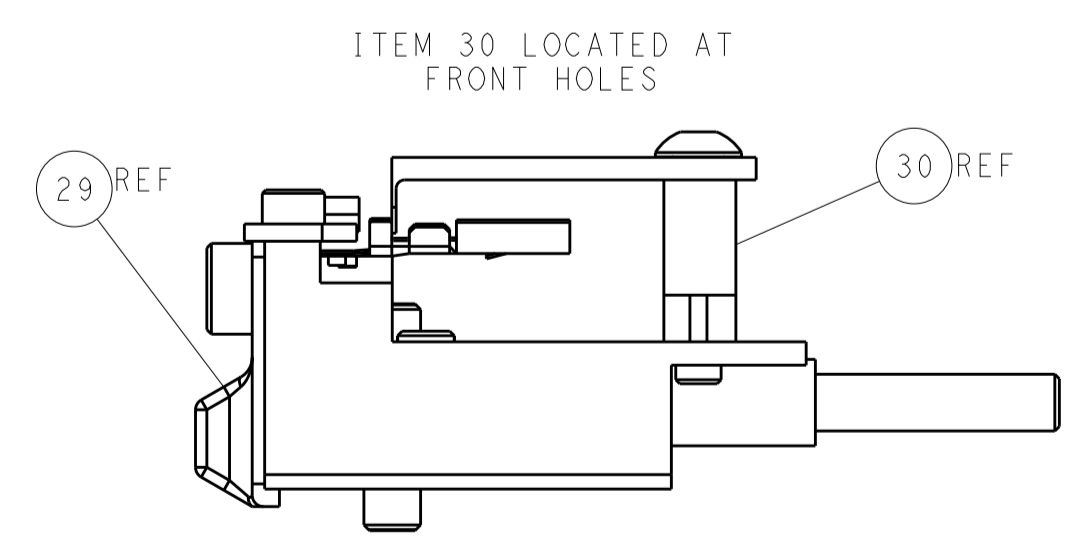

FEED TRACK POSITION GUIDE BY INSULATION BARREL

ATLANTIC VERSION
 Shown on sheets 1 of 4 & 2 of 4
 (Pacific version shown on sheets 3 of 4 & 4 of 4)

| | | | | | | | |
|-------------|---------|--|---------|--|---------|--|---------------------------|
| DIMENSIONS: | | TOLERANCES UNLESS OTHERWISE SPECIFIED: | | DWG: J. HOU 23FEB2016 | | TE Connectivity | |
| mm | 0 PLC ± | 1 PLC ± | 2 PLC ± | 3 PLC ± | 4 PLC ± | 5 PLC ± | Harrisburg, PA 17105-3608 |
| MATERIAL: | | FINISH: | | CHK: L. ZHANG 23FEB2016 | | NAME: Ocean Side Feed Applicator | |
| | | | | APVD: H. GUO 23FEB2016 | | PRODUCT SPEC: | |
| | | | | | | APPLICATION SPEC: | |
| | | | | WEIGHT: | | SIZE: CAGE CODE: DRAWING NO: RESTRICTED TO | |
| | | | | A1 00779 C=2836188 | | A | |
| | | | | Customer Accessible Production Drawing | | SCALE: 1:2 SHEET 2 OF 4 REV A | |

| PACIFIC VERSION TERMINATOR INTERFACE ADAPTER | PART NUMBER | REVISION | DESCRIPTION | FEED TYPE | APPLICATOR STYLE CONVERSION CHART | | | | | | |
|--|-------------|----------|--------------------------|--------------------------------|-----------------------------------|-----------------------|-----------|-------------|-----------|-----------|------------------------|
| | | | | | CONVERT TO | PART NUMBERS REQUIRED | | | | | |
| | 2-2836188-1 | A | FINE CRIMP HEIGHT ADJUST | MECHANICAL | PNEUMATIC FEED | 2119950-1 | 1338685-1 | 5-18022-5 | 2119641-2 | 2119799-1 | 2063440-1 |
| | 2-2836188-2 | A | FINE CRIMP HEIGHT ADJUST | PNEUMATIC | SERVO LATCH PLATE | 2119951-1 | - | 8-2836188-5 | 1901094-3 | - | 2168400-6 (QUANTITY 2) |
| | | | | | SMART APPLICATOR | 2161326-1 | - | 8-2836188-4 | - | - | |
| | | | | | MECHANICAL FEED | 2119949-1 | 1338685-1 | 5-18022-5 | 2119653-2 | - | - |
| | 2-2836188-5 | A | FINE CRIMP HEIGHT ADJUST | SERVO LATCH PLATE ⁴ | SERVO LATCH PLATE | 2119951-1 | - | 8-2836188-5 | 1901094-3 | - | 2168400-6 (QUANTITY 2) |
| | | | | | SMART APPLICATOR | 2161326-1 | - | 8-2836188-4 | - | - | |
| | 2-2836188-7 | A | FINE CRIMP HEIGHT ADJUST | NONE | - | - | - | - | - | - | - |
| | 7-2836188-7 | A | CRIMP TOOLING KIT | - | - | - | - | - | - | - | - |

| APPLICATOR DATA | | |
|--------------------------------------|----------------|------|
| CRIMP | SIZE | TYPE |
| WIRE | 1.55 mm [.061] | F |
| INSUL | 2.20 mm [.087] | O |
| APPLICATOR INSTRUCTIONS 408-10389 | | |

| TERMINAL DATA: MFG TERMINAL | | FCI CRIMP SPECIFICATION | |
|--|------------------------|---|---------------------|
| TERMINAL NAME: TERMINAL, SOCKET | | | |
| WIRE STRIP LENGTH 4.33-5.09 mm [1.70-.200 IN] | | INSULATION DIAMETER RANGE 1.40-1.90 mm [0.055-.075 IN] | |
| TERMINAL APPLICATION SPECIFICATION | PC260CC2SXXX0 Rev N | - | - |
| TERMINALS APPLIED | | | |
| TE TERMINAL | MFG TERMINAL | TE TERMINAL | MFG TERMINAL |
| 2113954-1 | PPI0000590(FCI/DELPHI) | 2113954-2 | 243467448(RENAULT) |
| 2113954-3 | 47059453/2(IMDS) | 2113954-4 | F156000(FCI/DELPHI) |
| 2113954-5 | 243461905(RENAULT) | 2113954-6 | 90401790/1(IMDS) |

| WIRE SIZE | CRIMP HEIGHT mm [INCH] | CRIMP HEIGHT REFERENCE SETTING |
|-----------|--------------------------------|--------------------------------|
| 0.75mm2 | 1.20 +/- 0.04 [0.047 +/- .002] | 7.8 |
| 0.50mm2 | 1.09 +/- 0.04 [0.043 +/- .002] | 9.0 |

- RECOMMENDED SPARE PARTS
- GREASE BEARING SURFACES LIGHTLY
- 3. LUBRICATE DAILY PER THE APPLICATOR INSTRUCTION SHEET SUPPLIED WITH THE APPLICATOR.
- APPLICATOR SPECIFIC DATA TO BE ENTERED INTO BLANK MEMORY CHIP AT ASSEMBLY. SEE BELOW FOR PART NUMBER:
 MECHANICAL FEED WITH "SMART APPLICATOR" CONVERSION: 8-2836188-4
 PNEUMATIC FEED WITH "SMART APPLICATOR" CONVERSION: 8-2836188-4
 SERVO FEED WITH "FINE CRIMP HEIGHT ADJUST": 8-2836188-5
- 5. ADJUSTMENT OF THE STRIPPER MAY BE REQUIRED WHEN MOVING THE APPLICATOR BETWEEN BENCH AND LEADMAKER APPLICATIONS.
- APPLY PART NUMBER 1-23419-5 LOCTITE TO THREADS OF ITEM 62.
 APPLY PART NUMBER 2-23419-6 LOCTITE TO THREADS OF ITEM 242.
- GREASE THREADS, GROOVE AND O-RING ON ITEMS 139 & 152.
- MAGNET MUST BE ORIENTED CORRECTLY IN ORDER TO PROPERLY ACTUATE THE COUNTER.
- CRIMP HEIGHT REFERENCE SETTING WAS THE SETTING USED WHEN THE APPLICATOR WAS QUALIFIED AT THE FACTORY. ADJUSTMENT MAY BE NECESSARY WHEN RUNNING APPLICATOR IN THE FIELD.
- SPARE FEED CAM STORAGE LOCATION REFER TO INSTRUCTION SHEET FOR ADDITIONAL INFORMATION.
- TO CONVERT THE APPLICATOR TO A NON-CARRIER CUTTING STYLE, REMOVE ITEM 13 AND ATTACH TO THE LOCATION ON BACK SIDE OF THE HOUSING. REFER TO INSTRUCTION SHEET FOR ADDITIONAL INFORMATION.

***WARNING**
 ON INSTALLATION, SET WIRE DISC, ITEM 40 TO LARGEST WIRE SIZE SETTING. USE OF SETTINGS BELOW MINIMUM REQUIRED CRIMP HEIGHT SETTING WILL CAUSE DAMAGE TO CRIMP TOOLING.

PACIFIC VERSION
 Shown on sheets 3 of 4 & 4 of 4
 (Atlantic version shown on sheets 1 of 4 & 2 of 4)

| SET UP GAUGE | LOC | DIST | REVISIONS | | | |
|--------------|-----|------|-----------|-------------|----|------|
| 2119599-1 | A | 66 | REV | DATE | BY | APPD |
| | | | - | SEE SHEET 1 | - | - |

| | | | | | | | |
|-----|-----|-----|-----|-----|-------------|-------------------------------------|---------|
| - | 1 | 1 | 1 | 1 | 2119782-1 | FINE ADJUST HEAD ASM, PACIFIC STYLE | 251 |
| - | - | - | 1 | - | 2119640-1 | PUSH ROD, AIR FEED | 250 |
| - | - | - | 1 | - | 2079988-1 | BUSHING, LCH5-12, MISUMI | 249 |
| - | 1 | 1 | 1 | 1 | 1-22279-3 | SPRING, COMPRESSION | 246 |
| - | 1 | 1 | 1 | 1 | 2119082-1 | CAM, SNAIL, INSULATION ADJUSTMENT | 244 |
| - | 1 | 1 | 1 | 1 | 2079764-1 | WASHER, WAVE SPRING, CREST-TO-CREST | 243 |
| - | 1 | 1 | 1 | 1 | 2119083-1 | RETAINER, INSULATION DIAL | 242 |
| - | 1 | 1 | 1 | 1 | 7-18023-7 | SCR, SKT HD CAP M3 X 4.0 | 241 |
| - | - | 2 | - | - | 2168400-6 | SHCS, LOW HEAD, RoHS, M5 X 16 | 240 |
| - | - | - | - | 1 | 2119580-1 | MECHANICAL FEED ASSEMBLY | 239 |
| - | - | - | 1 | - | 2063440-1 | AIR FEED MODULE | 238 |
| - | - | 1 | - | - | 2119740-2 | TAG, IDENTIFICATION | 213 |
| - | - | 1 | - | - | 1901094-3 | SPACER, FEEDER | 198 |
| - | - | - | 2 | - | 21045-3 | RING, RETAIN, EXTERN, 3/16 CRESCENT | 172 |
| - | 1 | 1 | 1 | 1 | 994969-1 | MAGNET, RARE EARTH HIGH ENERGY | 166 |
| - | REF | REF | REF | REF | 994970-2 | COUNTER, MAGNETIC | 164 |
| - | - | - | 1 | - | 240638-1 | SPRING, FEED FINGER | 163 |
| - | 1 | 1 | 1 | 1 | 8-21084-1 | O-RING, .801 ID, .070 DIA. MAT. | 152 |
| - | - | - | 1 | - | 2119641-2 | FEED CAM, AIR FEED | 151 |
| - | 1 | 1 | 1 | 1 | 2119798-2 | DETENT PIN | 145 |
| - | 1 | 1 | 1 | 1 | 2079383-8 | SCR, BHSC, RoHS (M4 X 16) | 144 |
| - | 4 | 4 | 4 | 4 | 2168400-5 | SHCS, LOW HEAD, RoHS, M4 X 20 | 143 |
| - | - | - | - | 1 | 2119653-2 | FEED CAM, POST FEED | 142 |
| - | 1 | 1 | 1 | 1 | 1-2119656-0 | APPLICATOR BASIC ASSEMBLY, SF | 141 |
| - | 1 | 1 | 1 | 1 | 2119650-1 | RAM, ASIAN STYLE, SIDE FEED | 140 |
| - | 1 | 1 | 1 | 1 | 2119092-2 | BOLT, ADJUSTMENT | 139 |
| - | - | - | 1 | - | 3-23627-7 | PIN, RETAIN, GRVD, 3/16 X .854 | 137 |
| - | - | - | 1 | - | 2119799-1 | HOLDER, FEED FINGER, AF | 136 |
| - | - | REF | - | - | SEE NOTE 4 | MEMORY CHIP, PROGRAMMED | 135 |
| - | - | 1 | - | - | 1633743-1 | SERVO FEED LATCH ASM | 133 |
| - | - | REF | - | - | 2119944-1 | FEED FINGER ASSEMBLY, SF | 117 |
| - | 1 | 1 | 1 | 1 | 455888-6 | SPACER, CRIMPER | 82 |
| - | 1 | 1 | 1 | 1 | 2119956-1 | DOCUMENTATION PACKAGE | 71 |
| - | 1 | - | 1 | 1 | 2119740-1 | TAG, IDENTIFICATION | 67 |
| - | 2 | 2 | 2 | 2 | 2168078-1 | SCREW, DRIVE, RH, RoHS, 2 x .188 | 66 |
| - | 1 | 1 | 1 | 1 | 2119793-1 | LIMITER, ADJUSTMENT BOLT | 63 |
| - | 3 | 3 | 3 | 3 | 992763-5 | SCR, SET, SOC, CONE POINT, M3 X 4.0 | 62 |
| - | - | - | 1 | 1 | 5-18022-5 | SCR, HEX HD CAP, M4 X 6.0 | 59 |
| - | - | - | 1 | 1 | 1338685-1 | PAWL, FEED | 56 |
| - | 2 | 2 | 2 | 2 | 1-2168083-0 | SCR, SKT HD CAP, RoHS, M4 X 10 | 53 |
| - | 1 | 1 | 1 | 1 | 5018030-1 | NUT, HEX, REG, RoHS, M3 | 52 |
| - | 1 | 1 | 1 | 1 | 811242-5 | BUMPER, HOLD DOWN | 51 |
| - | 1 | 1 | 1 | 1 | 690753-2 | SPACER, TONKER | 50 |
| - | - | - | 1 | 2 | 18023-9 | SCR, SKT HD CAP M4 X 6.0 | 49 |
| - | - | - | - | 1 | 2119652-1 | FEED CAM, PRE FEED | 48 |
| - | 1 | 1 | 1 | 1 | 2079383-7 | SCR, BHSC, RoHS (M8 X 25) | 41 |
| - | 1 | 1 | 1 | 1 | 2119645-1 | DISC, NUMBERED FA WIRE ADJUSTMENT | 40 |
| - | 1 | 1 | 1 | 1 | 2119957-1 | APPLICATOR SHIM PACK | 39 |
| - | 1 | 1 | 1 | 1 | 1-2119644-2 | RAM WASHER, PRECISION | 38 |
| - | 1 | 1 | 1 | 1 | 1752356-3 | SUPPORT, TERMINAL | 34 |
| - | 2 | 2 | 2 | 2 | 2079383-5 | SCR, BHSC, RoHS (M4 X 20) | 33 |
| - | 1 | 1 | 1 | 1 | 2161328-1 | HEX HEAD, FLANGED, M5 X 8mm LONG | 32 |
| - | 1 | 1 | 1 | 1 | 1320908-3 | SPACER, STRIP GUIDE | 30 |
| - | 1 | 1 | 1 | 1 | 2119959-2 | ASSEMBLY, STRIP GUIDE | 29 |
| - | 1 | 1 | 1 | 1 | 455888-3 | SPACER, CRIMPER | 28 |
| - | 1 | 1 | 1 | 1 | 1320928-2 | STRIP GUIDE | 24 |
| - | 1 | 1 | 1 | 1 | 2168083-2 | SCR, SKT HD CAP, RoHS, M4 X 8.0 | 21 |
| - | 2 | 2 | 2 | 2 | 1-18028-2 | WASHER, FLAT, REG M4 | 20 |
| - | 1 | 1 | 1 | 1 | 2119533-1 | STRIPPER, SIDE FEED | 19 |
| - | 1 | 1 | 1 | 1 | 2119806-1 | INSERT, SHEAR | 13 |
| - | 1 | 1 | 1 | 1 | 3-22280-3 | SPRING, COMPRESSION | 12 |
| - | 1 | 1 | 1 | 1 | 1-356885-4 | STOP, SHEAR | 11 |
| - | 1 | 1 | 1 | 1 | 2119805-1 | SHEAR HOLDER, FRONT | 10 |
| - | 1 | 1 | 1 | 1 | 1803095-1 | FLOATING SHEAR, FRONT | 9 |
| - | 1 | 1 | 1 | 1 | 7-1803056-9 | ANVIL, COMBINATION | 8 |
| - | - | - | - | - | - | - | 7 |
| - | - | - | - | - | - | - | 6 |
| - | 1 | 1 | 1 | 1 | 2119757-4 | DEPRESSOR, SHEAR | 5 |
| - | 1 | 1 | 1 | 1 | 238011-9 | BLOCK, CRIMPER SPACER | 4 |
| - | 1 | 1 | 1 | 1 | 1803328-2 | CRIMPER, INSULATION O | 3 |
| - | 1 | 1 | 1 | 1 | 455888-6 | SPACER, CRIMPER | 2 |
| - | 1 | 1 | 1 | 1 | 7-1633860-6 | CRIMPER, WIRE | 1 |
| -77 | -27 | -25 | -22 | -21 | PART NO | DESCRIPTION | ITEM NO |

| DIMENSIONS: | | TOLERANCES UNLESS OTHERWISE SPECIFIED: | | DATE | | NAME | |
|--|---------|--|---------|---------|---------|--------|--------|
| mm | 0 PLC ± | 1 PLC ± | 2 PLC ± | 3 PLC ± | 4 PLC ± | ANGLES | FINISH |
| MATERIAL | | | | WEIGHT | SCALE | SHEET | REV |
| Customer Accessible Production Drawing | | | | SCALE | 1:2 | SHEET | 3 of 4 |

| LOC | | DIST | | REVISIONS | | | |
|-----|----|------|-----|-------------|------|-----|------|
| A | 66 | P | LTM | DESCRIPTION | DATE | OWN | APVD |
| | | - | - | SEE SHEET 1 | - | - | - |

FEED TYPE MECHANICAL



PNEUMATIC

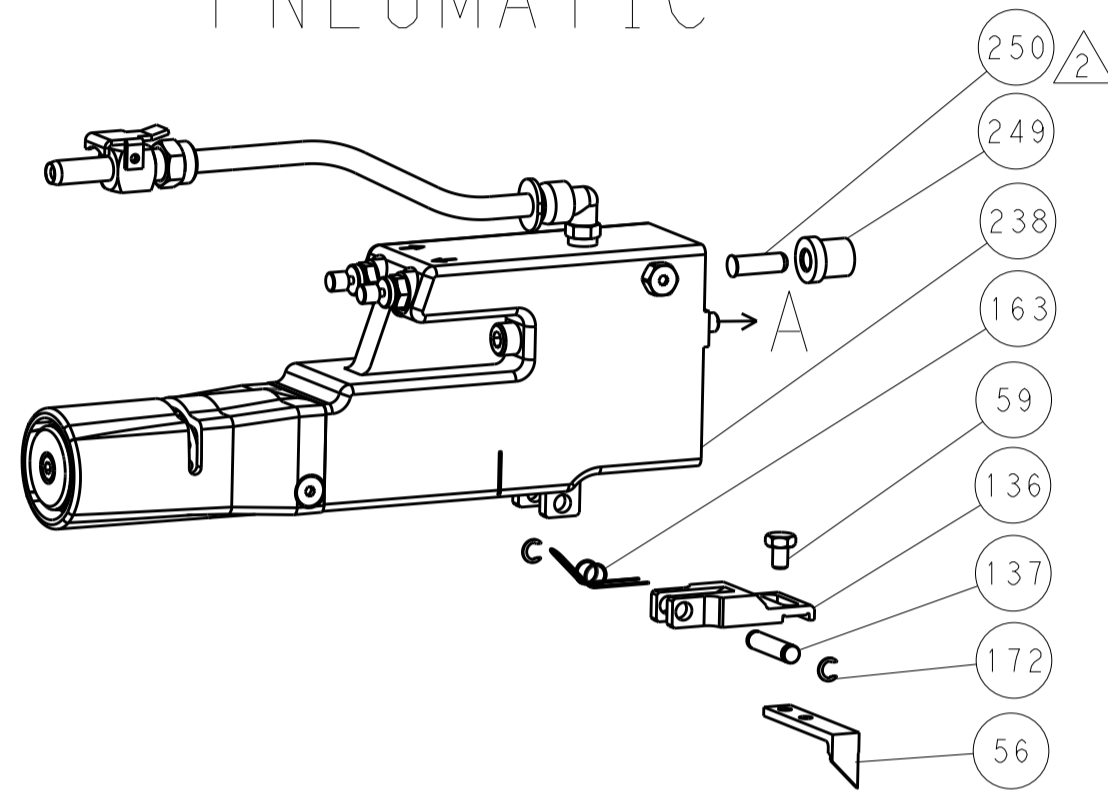

SERVO LATCH PLATE



CAM POSITIONS

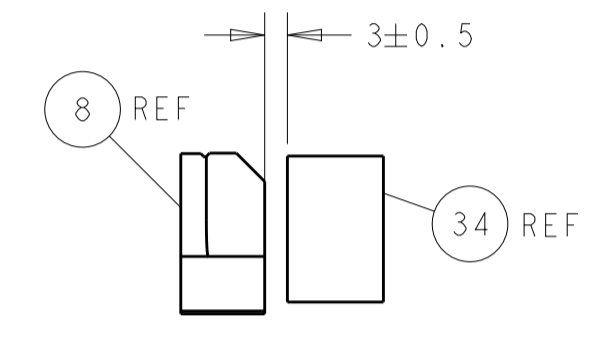
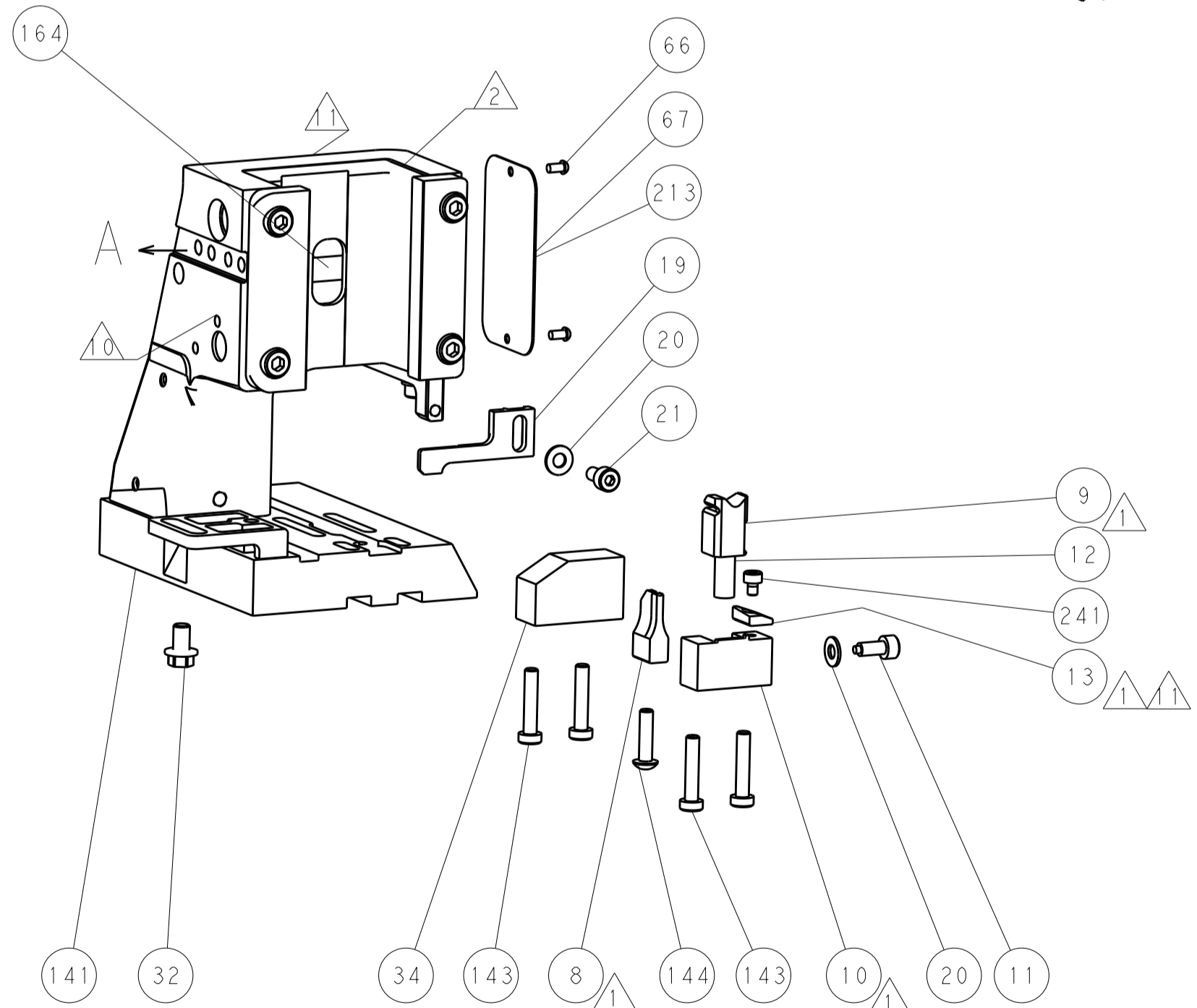
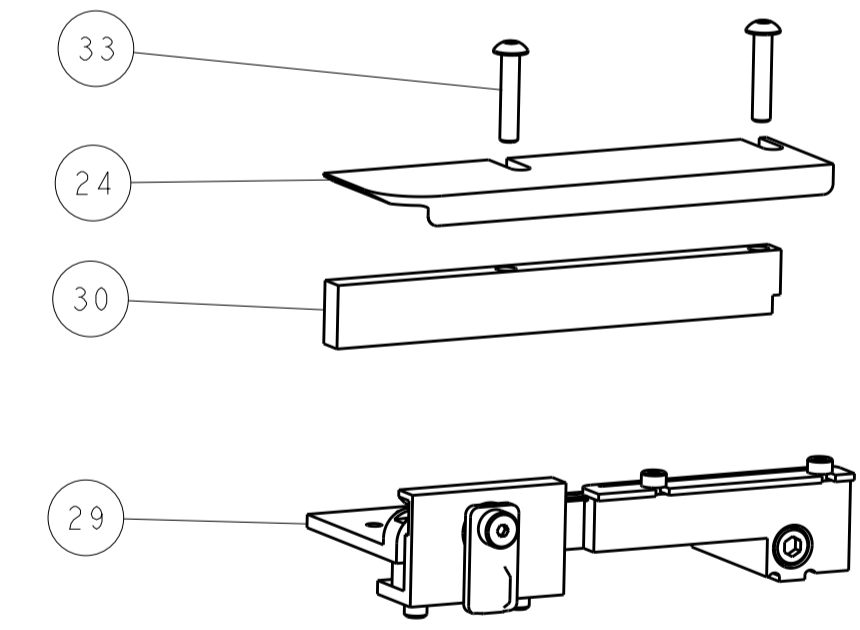
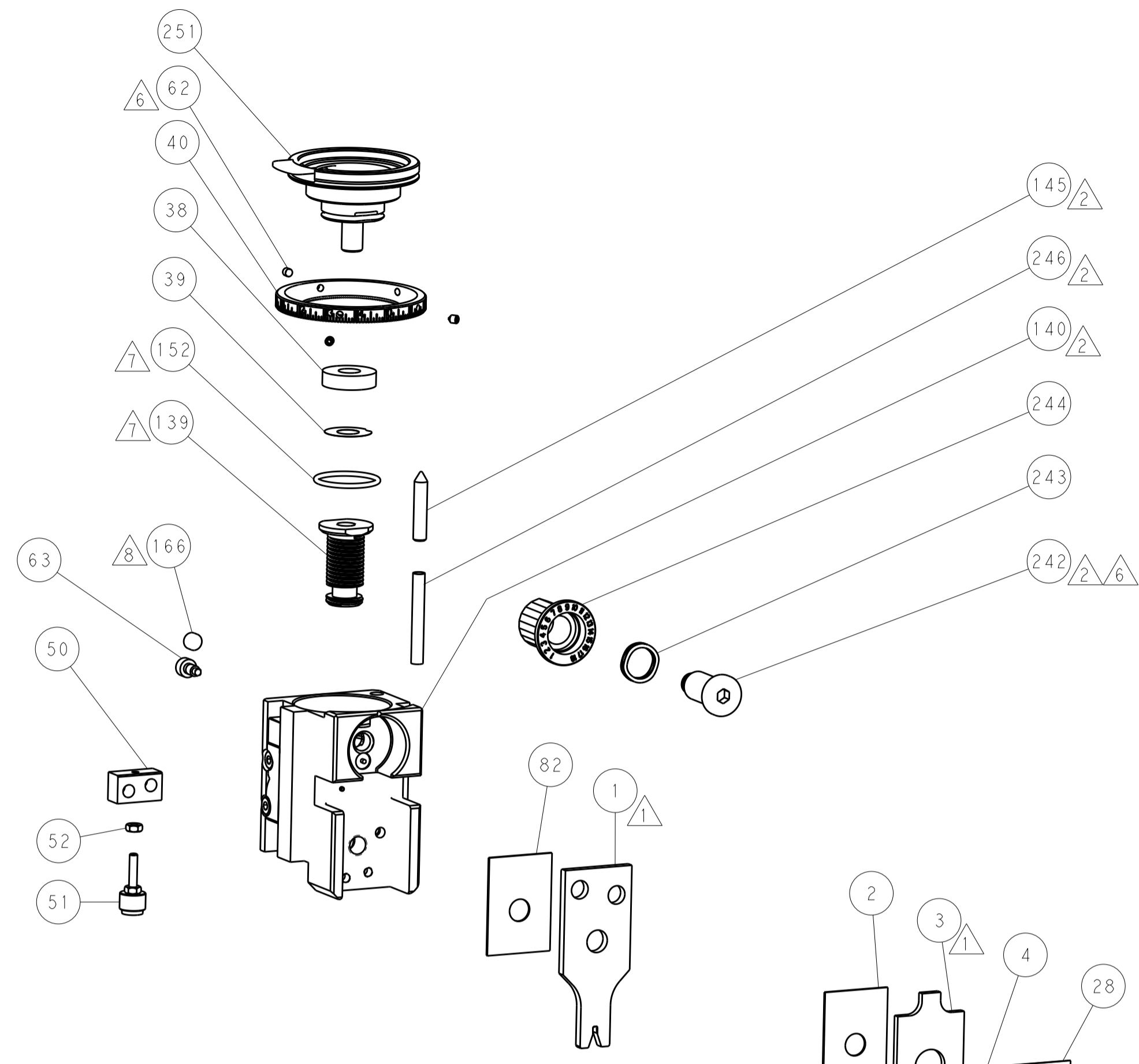

TERMINAL SUPPORT LOCATION

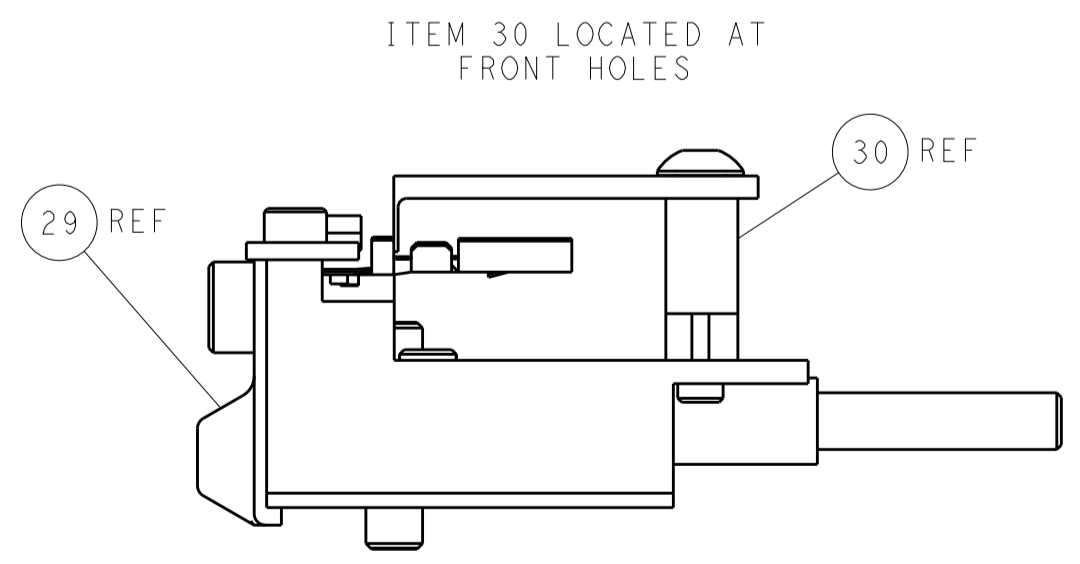

FEED TRACK POSITION
GUIDE BY INSULATION BARREL

PACIFIC VERSION
 Shown on sheets 3 of 4 & 4 of 4
 (Atlantic version shown on sheets 1 of 4 & 2 of 4)

| | | | | | | | | | | | | |
|-------------|--------|--|--|-----------------------|-----------|-------------------------|--|---|-------|----------------------------------|-----|---|
| DIMENSIONS: | | TOLERANCES UNLESS OTHERWISE SPECIFIED: | | DWG: J. HOU 23FEB2016 | | CHK: L. ZHANG 23FEB2016 | | APVD: H. GUO 23FEB2016 | | NAME: Ocean Side Feed Applicator | | |
| mm | 0 PLC | ± | | SIZE | CAGE CODE | DRAWING NO | RESTRICTED TO | STE TE Connectivity Harrisburg, PA 17105-3608 | | | | |
| | 1 PLC | ± | | SCALE | 1:2 | 00779 | Customer Accessible Production Drawing | Customer Accessible Production Drawing | | | | |
| | 2 PLC | ± | | SHEET | 4 | 2836188 | SCALE | 1:2 | SHEET | 4 | REV | A |
| | 3 PLC | ± | | OF | 4 | | | | | | | |
| | 4 PLC | ± | | | | | | | | | | |
| | ANGLES | ± | | | | | | | | | | |
| MATERIAL | FINISH | | | | | | | | | | | |