

RELEASED FOR PUBLICATION 20

THIS DRAWING IS UNPUBLISHED.

ALL RIGHTS RESERVED.

BY -

© COPYRIGHT 20

REVISIONS

P	LTR	DESCRIPTION	DATE	DWN	APVD
	A	RELEASED	15AUG16	JL	IY

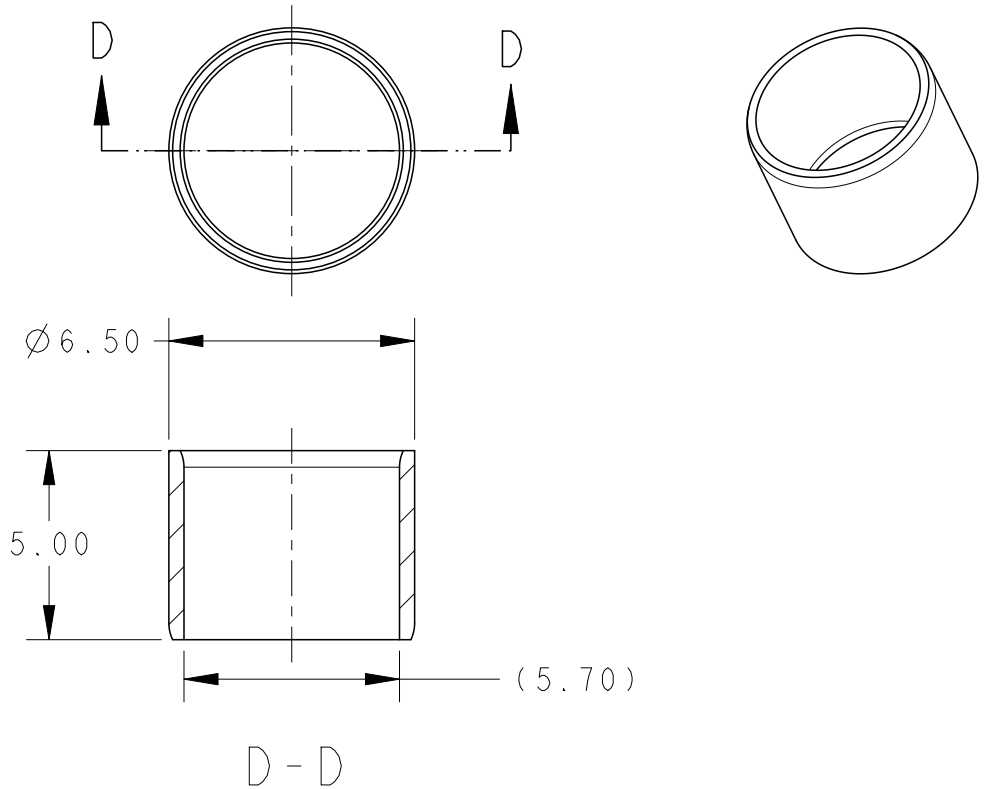

1 MATERIAL: COPPER ALLOY

2 FINISH: BARE

3. PARTS MUST BE FREE OF BURRS, CRACKS, OR OTHER VISUAL IMPERFECTIONS THAT MAY AFFECT FIT FORM OR FUNCTION

4. FERRULE APPLICATION INFORMATION FOR HVA280 PHI PLUG:

INNER FERRULE P/N	OUTER FERRULE P/N	CABLE TYPE	CABLE OUTER DIAMETER
2301703-1	2301705-1	3MM2	5.0 - 5.6MM

- 1 AS SHOWN

DIMENSIONS: mm	DWN J.LI	16MAR16	MATERIAL	1	FINISH	2 -	
	CHK XX.LI	20MAR16	TE Connectivity				
TOLERANCES UNLESS OTHERWISE SPECIFIED: $\pm 0.1$	APVD I.YIN	15AUG16					NAME
	0 PLC $\pm$	PRODUCT SPEC	SIZE	CAGE CODE	DRAWING NO	RESTRICTED TO	
1 PLC $\pm 0.2$	APPLICATION SPEC	A 4	-	C-2301703	-		
2 PLC $\pm 0.10$	WEIGHT	CUSTOMER DRAWING				SCALE	8:1
3 PLC $\pm 0.013$						SHEET	1 OF 1
4 PLC $\pm 0.0001$						REV	A
ANGLES $\pm$							