

THIS DRAWING IS UNPUBLISHED. RELEASED FOR PUBLICATION 20
 © COPYRIGHT 20 BY - ALL RIGHTS RESERVED.

REVISIONS				
P	LTR	DESCRIPTION	DATE	APVD
C		REVISED	03JUN2015	JAB DJL
C1		REVISED	23DEC2015	DJL DJL
D		REVISED	26APR2016	RM RJD
E		REVISED	02MAY2017	JAB ERL

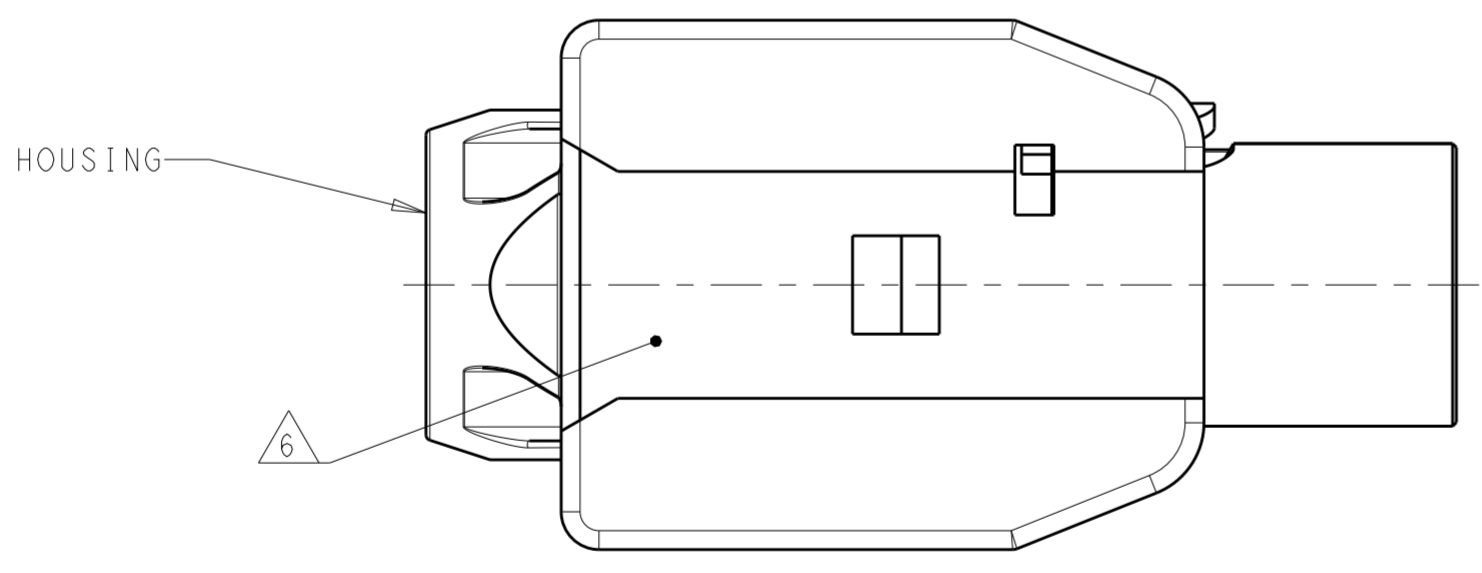
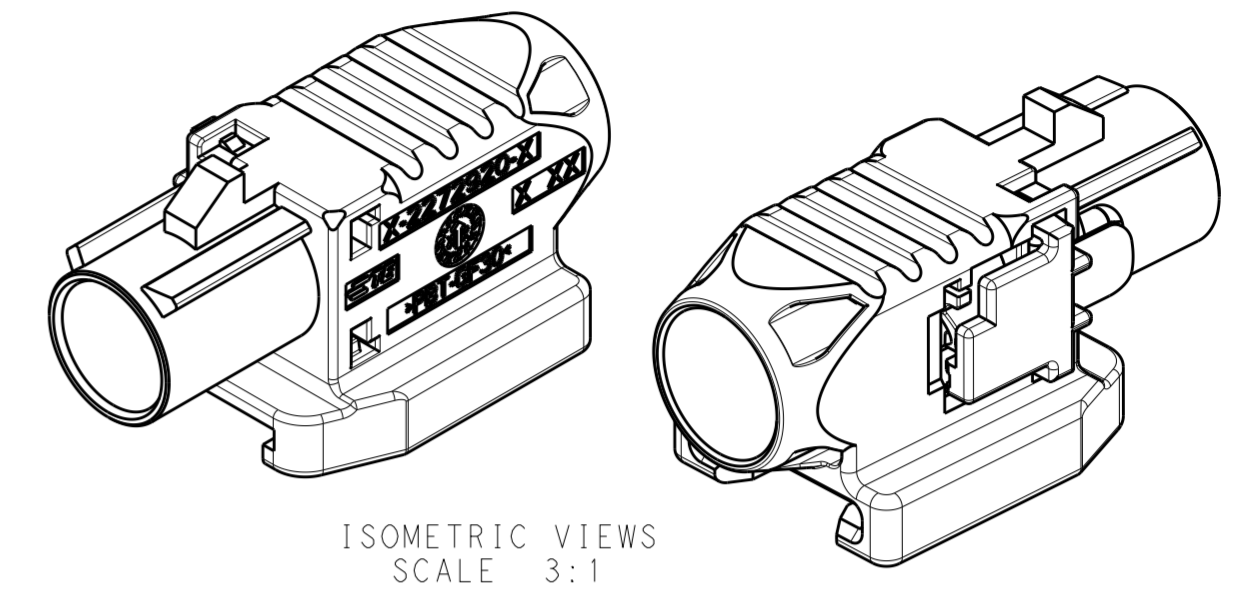
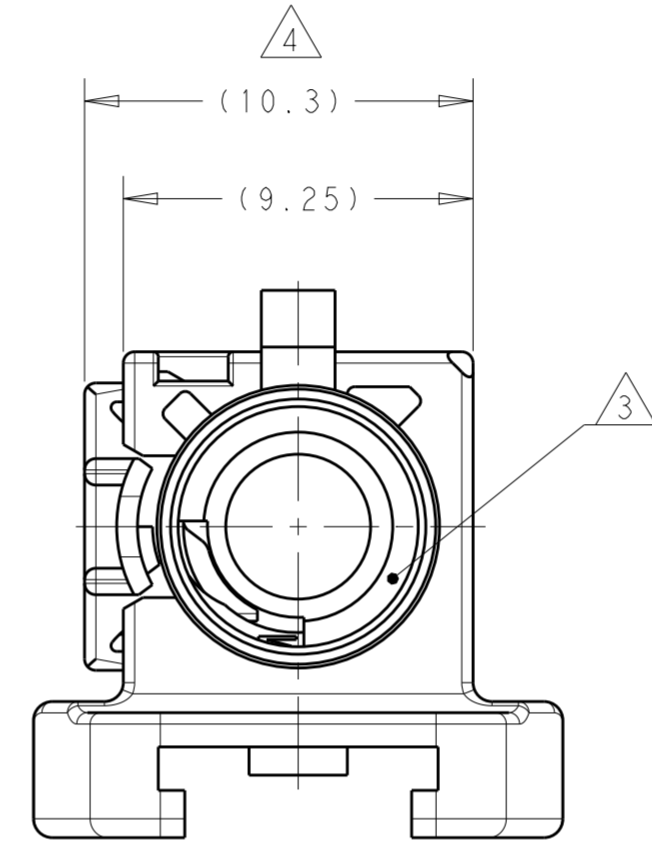
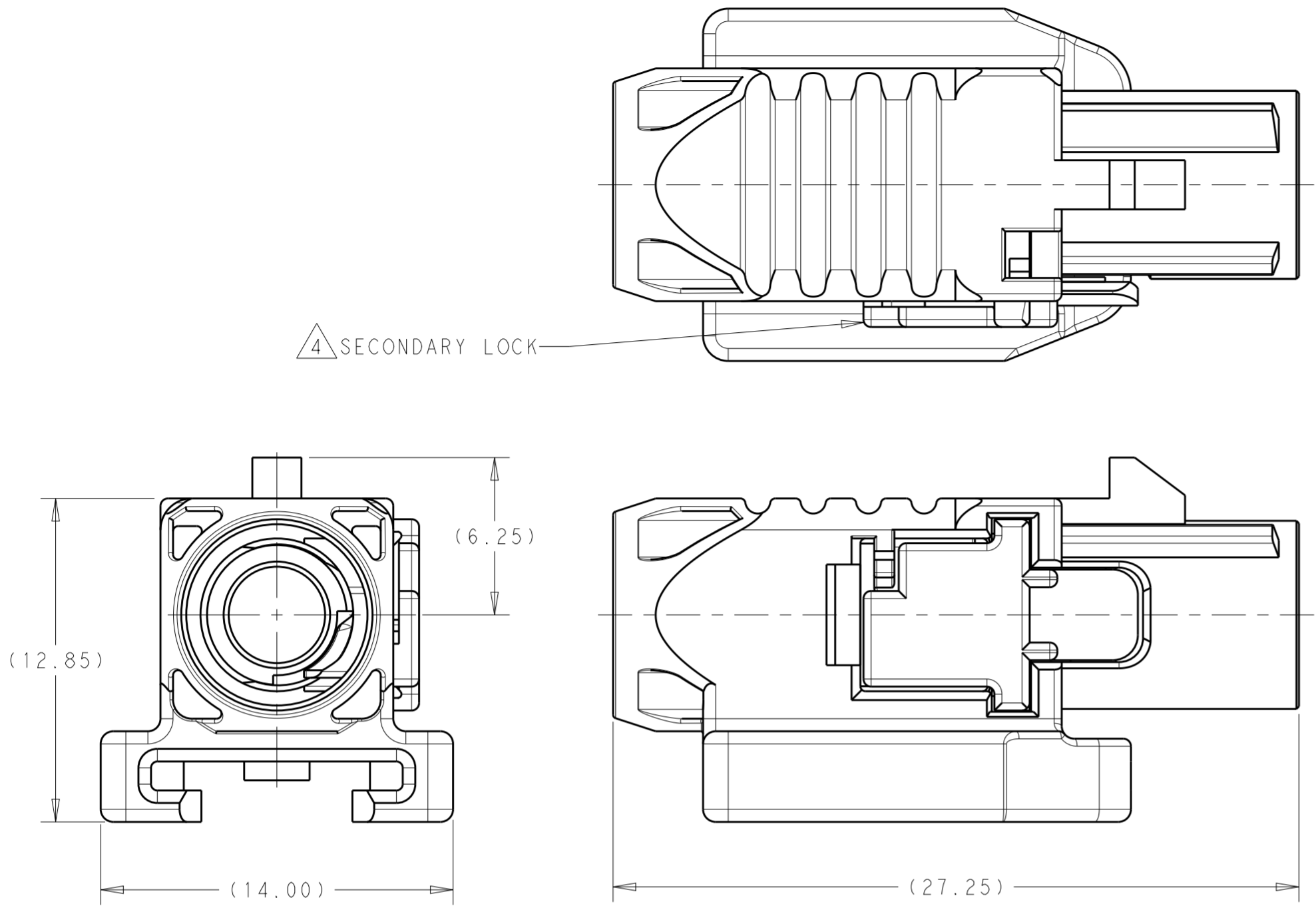

- 1 HOUSING - POLYESTER PBT, COLOR: SEE TABLE, GLASS FILLED.
 SECONDARY LOCK - POLYESTER PBT, WATER BLUE GLASS FILLED.
 CABLE ASSEMBLY - SEE DRAWING 2203265.
- 2 CABLE ASSEMBLY: SEE TABLE.
- 3 MALE INTERFACE PER ISO-20860-1, ISO-20860-2, SAE/USCAR-17, SAE/USCAR-18.
- 4 SECONDARY LOCK IN PRE-SET POSITION. IF SECONDARY LOCK IS IN FULLY LOCKED POSITION,
 SEE 408-162008 FOR INSTRUCTIONS TO RE-SET SECONDARY LOCK TO PRE-SET POSITION.
- 5. 2272530-1 AS SHOWN.
- 6 HONDA CLIP SLOT

2203265-[1] (SOLD SEPARATELY) SEE SHEET 2	Z	PER DETAIL Z	WATER BLUE	2-2272530-0
	N	PER DETAIL N	PASTEL GREEN	1-2272530-3
	M	PER DETAIL M	PASTEL ORANGE	1-2272530-2
	L	PER DETAIL L	CARMINE RED	1-2272530-1
	K	PER DETAIL K	CURRY	1-2272530-0
	I	PER DETAIL I	BEIGE	2272530-9
	H	PER DETAIL H	HEATHER VIOLET	2272530-8
	G	PER DETAIL G	BLUE GREY	2272530-7
	F	PER DETAIL F	NUT BROWN	2272530-6
	E	PER DETAIL E	LEAF GREEN	2272530-5
	D	PER DETAIL D	CLARET VIOLET	2272530-4
C	PER DETAIL C	SIGNAL BLUE	2272530-3	
B	PER DETAIL B	CREAM	2272530-2	
A	PER DETAIL A	JET BLACK	2272530-1	
CABLE ASSEMBLY QTY=1	CODING REF	KEYING	CODING COLOR	PART NUMBER

THIS DRAWING IS A CONTROLLED DOCUMENT.		DWN W. SOURBEER 12 JAN 2015	STE TE Connectivity
		CHK D. J. LANE 12 JAN 2015	
		APVD D. J. LANE 12 JAN 2015	
DIMENSIONS: mm 		PRODUCT SPEC 108-32137	NAME MALE HOUSING ASSEMBLY, HONDA CLIP SLOT, 1 POSITION, FAKRA
TOLERANCES UNLESS OTHERWISE SPECIFIED: 0 PLC ± 1 PLC ± 2 PLC ± 3 PLC ± 4 PLC ± ANGLES ± FINISH -		APPLICATION SPEC 114-32145	RESTRICTED TO
MATERIAL		WEIGHT	SIZE A2
1		Customer Drawing	SCALE 5:1 SHEET 1 OF 2 REV E

THIS DRAWING IS UNPUBLISHED. RELEASED FOR PUBLICATION 20
 © COPYRIGHT 20 BY - ALL RIGHTS RESERVED.

REVISIONS				
P	LTR	DESCRIPTION	DATE	APVD
-		SEE SHEET 1	-	-

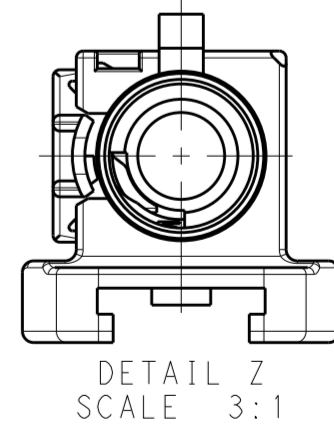
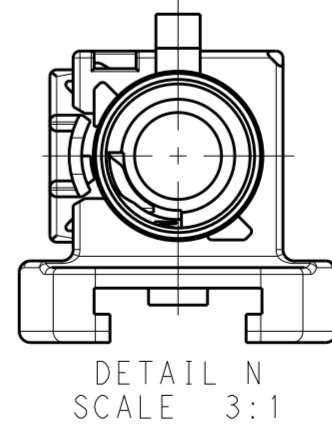
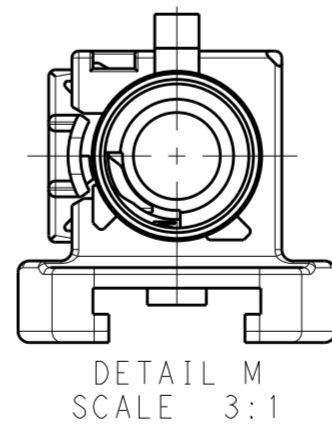
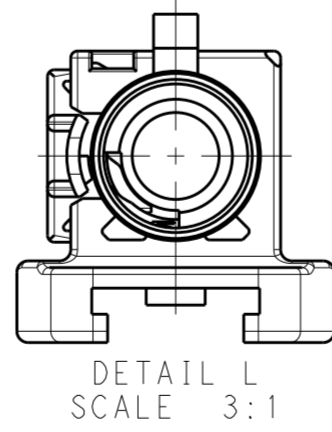
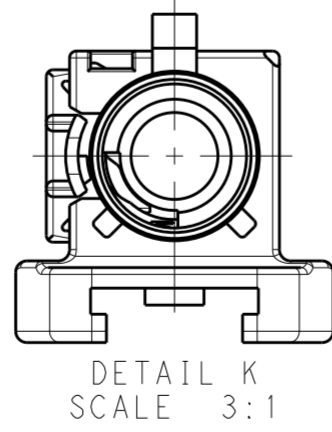
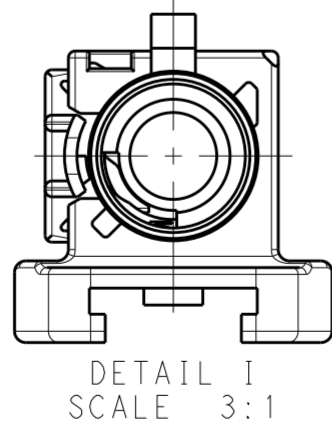
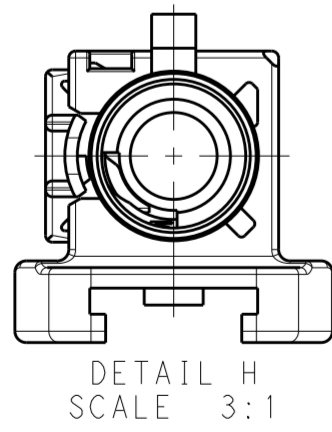
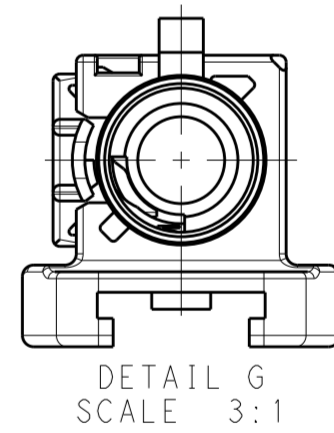
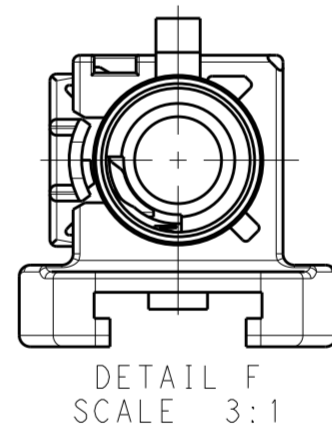
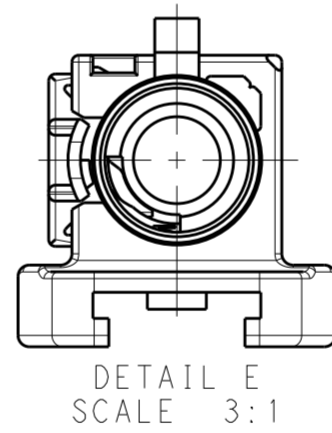
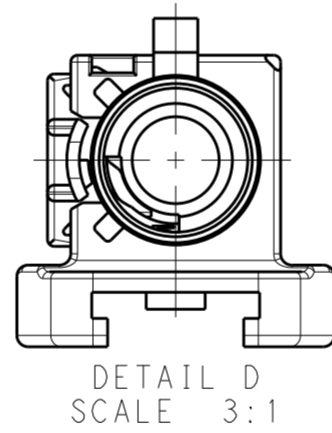
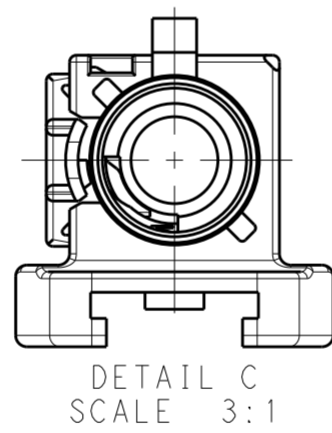
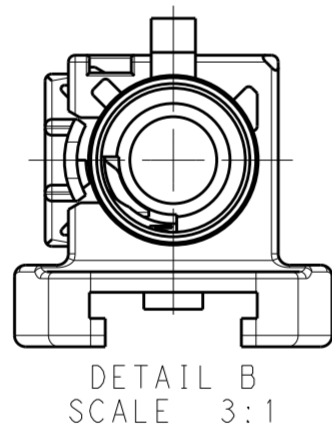
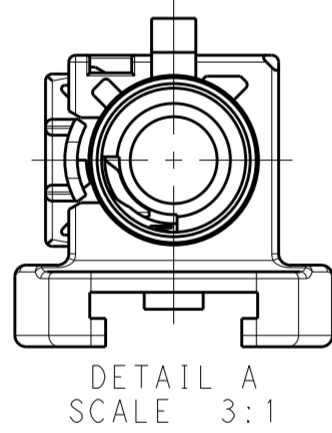
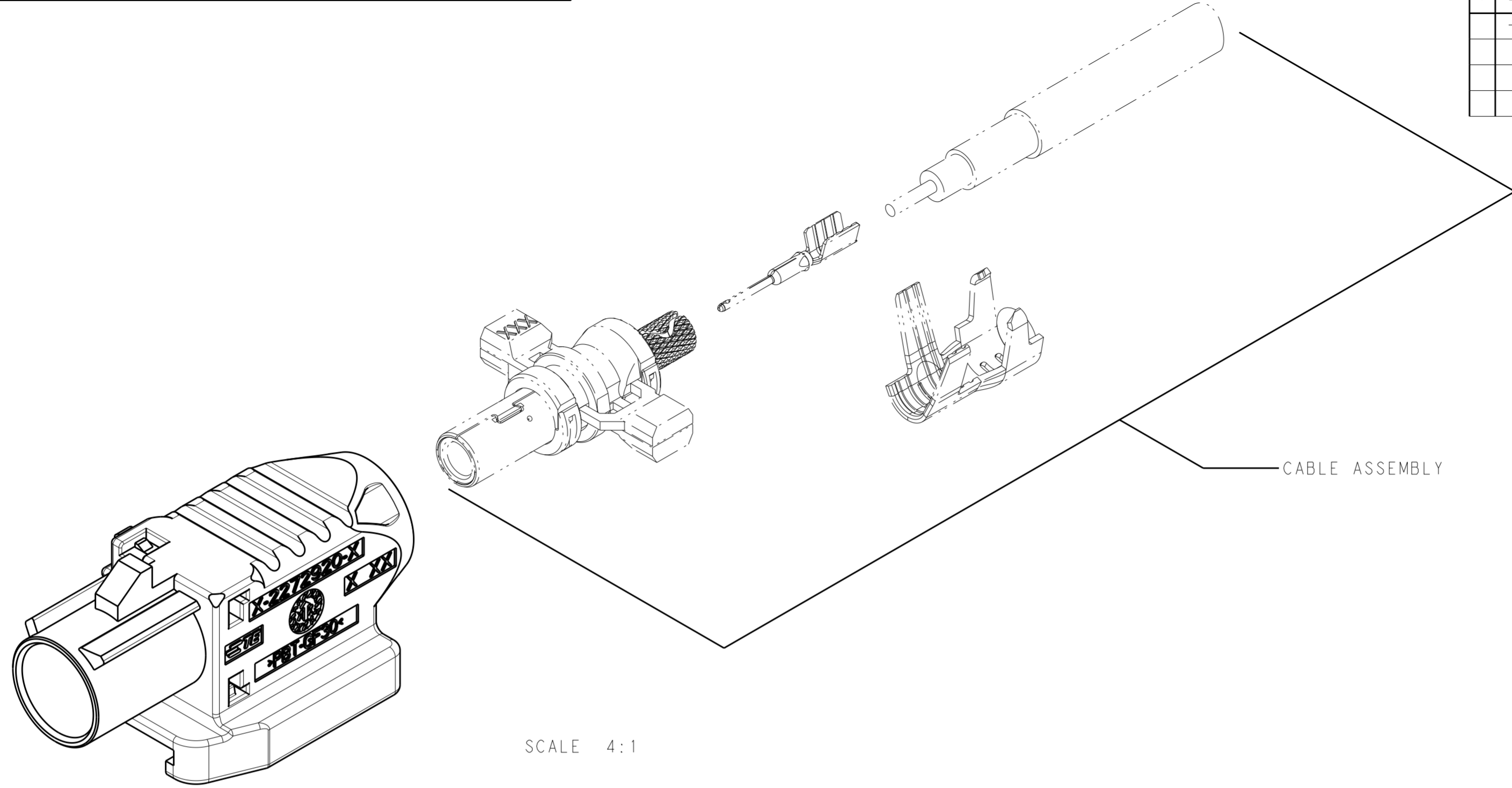

THIS DRAWING IS A CONTROLLED DOCUMENT.		DWN W. SOURBEER 12 JAN 2015	TE Connectivity	
		CHK D. J. LANE 12 JAN 2015		
		APVD D. J. LANE 12 JAN 2015	NAME MALE HOUSING ASSEMBLY, HONDA CLIP SLOT, 1 POSITION, FAKRA	
DIMENSIONS: mm		PRODUCT SPEC 108-32137	SIZE A2	CAGE CODE -
TOLERANCES UNLESS OTHERWISE SPECIFIED: 0 PLC ± 1 PLC ± 2 PLC ± 3 PLC ± 4 PLC ± ANGLES ± FINISH		APPLICATION SPEC 114-32145	DRAWING NO G-2272530	RESTRICTED TO -
MATERIAL -		WEIGHT -	SCALE 5:1 SHEET 2 OF 2 REV E	
		Customer Drawing		