

ATLANTIC VERSION TERMINATOR INTERFACE ADAPTER	PART NUMBER	REVISION	DESCRIPTION	FEED TYPE	APPLICATOR STYLE CONVERSION CHART						
					CONVERT TO	PART NUMBERS REQUIRED					
	2266997-2	A	FINE CRIMP HEIGHT ADJUST	PNEUMATIC	SERVO LATCH PLATE	2119951-1	-	8-2266997-5	1901094-3	-	2168400-6 (QUANTITY 2)
	2266997-5	A	FINE CRIMP HEIGHT ADJUST	SERVO LATCH PLATE	SMART APPLICATOR	2161326-1	-	8-2266997-4	-	-	-
	2266997-6	A	NON-CRIMP HEIGHT ADJUST	SERVO LATCH PLATE	PNEUMATIC FEED	2119950-1	1338683-8	5-18022-5	2119641-1	2119799-1	2063440-1
	2266997-7	A	FINE CRIMP HEIGHT ADJUST	NONE	-	-	-	-	-	-	-
	7-2266997-7	A	CRIMP TOOLING KIT	-	-	-	-	-	-	-	-
	-	-	-	-	-	-	-	-	-	-	-
	-	-	-	-	-	-	-	-	-	-	-

APPLICATOR DATA		
CRIMP	SIZE	TYPE
WIRE	3.96 mm [.156]	F
INSUL	5.54 mm [.218]	F

APPLICATOR INSTRUCTIONS 408-10389

TERMINAL DATA: KET TERMINAL		KET CRIMP SPECIFICATION	
TERMINAL NAME: TERMINAL, 6.4 EARTH RING			
WIRE STRIP LENGTH		INSULATION DIAMETER RANGE	
5.72-6.48 mm [.225-.255 IN]		Ø1.60-2.90 mm [.063-.114 IN]	
TERMINAL APPLICATION SPECIFICATION	KET Rev -	-	-
TERMINALS APPLIED			
TE TERMINAL	KET TERMINAL	TE TERMINAL	KET TERMINAL
2113860-1	ST710965-1	2113860-2	ST710965-3

WIRE SIZE	CRIMP HEIGHT mm [INCH]	CRIMP HEIGHT REFERENCE SETTING
AVSS 0.85 + 0.5	2.15 +/- 0.05 [.085 +/- .002]	7.7
AVSS 1.25	2.10 +/- 0.05 [.083 +/- .002]	7.5
AVSS 0.5 + 0.5	2.05 +/- 0.05 [.081 +/- .002]	8.6
AVSS 0.85	1.95 +/- 0.05 [.077 +/- .002]	9.3
AVSS 0.5	1.85 +/- 0.05 [.073 +/- .002]	10.3

- RECOMMENDED SPARE PARTS
- GREASE BEARING SURFACES LIGHTLY
- LUBRICATE DAILY PER THE APPLICATOR INSTRUCTION SHEET SUPPLIED WITH THE APPLICATOR.
- APPLICATOR SPECIFIC DATA TO BE ENTERED INTO BLANK MEMORY CHIP AT ASSEMBLY. SEE BELOW FOR PART NUMBER:
 PNEUMATIC FEED WITH "SMART APPLICATOR" CONVERSION: 8-2266997-4
 SERVO FEED WITH "FINE CRIMP HEIGHT ADJUST": 8-2266997-5
 SERVO FEED WITH "NON-CRIMP HEIGHT ADJUST": 8-2266997-6
- ADJUSTMENT OF THE STRIPPER MAY BE REQUIRED WHEN MOVING THE APPLICATOR BETWEEN BENCH AND LEADMAKER APPLICATIONS.
- APPLY PART NUMBER 1-23419-5 LOCTITE TO THREADS OF ITEM 62. APPLY PART NUMBER 2-23419-6 LOCTITE TO THREADS OF ITEM 242. FOR -6 ONLY APPLY PART NUMBER 1-23419-5 LOCTITE TO THREADS OF ITEM 37.
- GREASE THREADS, GROOVE AND O-RING ON ITEMS 35 & 252.
- MAGNET, ITEM 166 MUST BE ORIENTED CORRECTLY IN ORDER TO PROPERLY ACTUATE THE COUNTER.
- CRIMP HEIGHT REFERENCE SETTING WAS THE SETTING USED WHEN THE APPLICATOR WAS QUALIFIED AT THE FACTORY. ADJUSTMENT MAY BE NECESSARY WHEN RUNNING APPLICATOR IN THE FIELD.
- TERMINAL PITCH NOT COMPATIBLE WITH MECHANICAL FEED.
- TO CONVERT THE APPLICATOR TO A NON-CARRIER CUTTING STYLE, REMOVE ITEM 13 AND ATTACH TO THE LOCATION ON THE BACK SIDE OF THE HOUSING. REFER TO INSTRUCTION SHEET FOR ADDITIONAL INFORMATION.
- WHEN ASSEMBLING A NON CRIMP HEIGHT ADJUST APPLICATOR (-6) USE SHIMS FROM ITEM 260 TO ACHIEVE A NOMINAL SHIM HEIGHT OF 3.65.

***WARNING**
 ON INSTALLATION, SET WIRE DISC, ITEM 40 TO LARGEST WIRE SIZE SETTING. USE OF SETTINGS BELOW MINIMUM REQUIRED CRIMP HEIGHT SETTING WILL CAUSE DAMAGE TO CRIMP TOOLING.

- 2	2	2	2	2168083-1	SCR, SKT HD CAP, RoHS, M3 X 8.0	269	
- 1	1	1	1	1-1633782-2	FENCE	267	
- -	-	-	-	2119957-2	APPLICATOR SHIM PACK	260	
-77	-7	-6	-5	-2	PART NO	DESCRIPTION	ITEM NO

ATLANTIC VERSION
 Shown on sheets 1 of 4 & 2 of 4
 (Pacific version shown on sheets 3 of 4 & 4 of 4)

SET UP GAUGE	LOC	DIST	REVISIONS				
2119599-1	A	66	P LTR	DESCRIPTION	DATE	OWN	APVD
			A	RELEASED	230CT2015	RK	GB

- 1	1	1	1	1803078-2	SPACER, PRECISION	259
- 1	-	1	1	8-21084-0	O-RING, .676 ID, .070 DIA. MAT.	252
- -	-	-	1	2119640-1	PUSH ROD, AIR FEED	250
- -	-	-	1	2079988-1	BUSHING, LCH5-12, MISUMI	249
- -	-	-	1	2119641-1	FEED CAM, AIR FEED	248
- 1	-	1	1	2119798-1	DETENT PIN	247
- 1	-	1	1	1-22279-3	SPRING, COMPRESSION	246
- -	1	-	-	2161314-1	RAM, STEPPED, ATLANTIC, SF, NON-ADJ	245
- 1	1	1	1	2119082-8	CAM, SNAIL, INSULATION ADJUSTMENT	244
- 1	1	1	1	2079764-1	WASHER, WAVE SPRING, CREST-TO-CREST	243
- 1	1	1	1	2119083-1	RETAINER, INSULATION DIAL	242
- 1	1	1	1	7-18023-7	SCR, SKT HD CAP M3 X 4.0	241
- -	2	2	-	2168400-6	SHCS, LOW HEAD, RoHS, M5 X 16	240
- -	-	-	1	2063440-1	AIR FEED MODULE	238
- -	1	1	-	2119740-2	TAG, IDENTIFICATION	213
- -	1	1	-	1901094-3	SPACER, FEEDER	198
- -	-	-	2	21045-3	RING, RETAIN, EXTERN, 3/16 CRESCENT	172
- 1	1	1	1	994969-1	MAGNET, RARE EARTH HIGH ENERGY	166
- REF	REF	REF	REF	994970-2	COUNTER, MAGNETIC	164
- -	-	-	1	240638-1	SPRING, FEED FINGER	163
- -	-	-	1	3-23627-7	PIN, RETAIN, GRVD, 3/16 X .854	137
- -	-	-	1	2119799-1	HOLDER, FEED FINGER, AF	136
- -	REF	REF	-	SEE NOTE 4	MEMORY CHIP, PROGRAMMED	135
- -	1	1	-	1633743-1	SERVO FEED LATCH ASM	133
- -	REF	REF	-	2119944-1	FEED FINGER ASSEMBLY, SF	117
- 1	1	1	1	1-455888-4	SPACER, CRIMPER	82
- 2	2	2	2	2079383-4	SCR, BHSC, RoHS (M4 X 8)	79
- 1	1	1	1	1803096-1	EXTENSION PLATE	78
- 1	1	1	1	2119956-1	DOCUMENTATION PACKAGE	71
- 1	-	-	1	2119740-1	TAG, IDENTIFICATION	67
- 2	2	2	2	2168078-1	SCREW, DRIVE, RH, RoHS, 2 x .188	66
- 1	-	1	1	2119793-1	LIMITER, ADJUSTMENT BOLT	63
- 3	-	3	3	992763-5	SCR, SET, SOC, CONE POINT, M3 x 4.0	62
- 1	1	1	1	2079383-4	SCR, BHSC, RoHS (M4 X 8)	60
- -	-	-	1	5-18022-5	SCR, HEX HD CAP, M4 X 6.0	59
- -	-	-	1	1338683-8	FEED PAWL	56
- 4	4	4	4	2168400-1	SHCS, LOW HEAD, RoHS, M4 X 12	54
- 2	2	2	2	1-2168083-0	SCR, SKT HD CAP, RoHS, M4 X 10	53
- 1	1	1	1	5018030-1	NUT, HEX, REG, RoHS, M3	52
- 1	1	1	1	811242-5	BUMPER, HOLD DOWN	51
- 1	1	1	1	690753-2	SPACER, TONKER	50
- -	-	-	1	18023-9	SCR, SKT HD CAP M4 X 6.0	49
- 1	1	1	1	2119656-9	APPLICATOR BASIC ASSEMBLY, SF	46
- 1	-	1	1	1-2079383-5	SCR, BHSC, RoHS (M8 X 40)	41
- 1	-	1	1	2119645-1	DISC, NUMBERED FA WIRE ADJUSTMENT	40
- 1	-	1	1	2119957-1	APPLICATOR SHIM PACK	39
- 1	1	1	1	2119644-2	RAM WASHER, PRECISION	38
- 1	1	1	1	2119085-1	FA HEAD, ATLANTIC STYLE	37
- 1	-	1	1	2119092-1	BOLT, ADJUSTMENT	35
- 1	1	1	1	1752356-4	SUPPORT, TERMINAL	34
- 2	2	2	2	2079383-5	SCR, BHSC, RoHS (M4 X 20)	33
- 1	1	1	1	2161328-1	HEX HEAD, FLANGED, M5 x 8mm LONG	32
- 1	1	1	1	1320908-1	SPACER, STRIP GUIDE	30
- 1	1	1	1	2119959-1	ASSEMBLY, STRIP GUIDE	29
- 1	1	1	1	455888-3	SPACER, CRIMPER	28
- 1	1	1	1	1320928-4	STRIP GUIDE	24
- 1	1	1	1	2168083-2	SCR, SKT HD CAP, RoHS, M4 X 8.0	21
- 2	2	2	2	1-18028-2	WASHER, FLAT, REG M4	20
- 1	1	1	1	2119533-1	STRIPPER, SIDE FEED	19
- 1	1	1	1	2119806-1	INSERT, SHEAR	13
- 1	1	1	1	3-22280-3	SPRING, COMPRESSION	12
- 1	1	1	1	1-356885-4	STOP, SHEAR	11
- 1	1	1	1	2119805-1	SHEAR HOLDER, FRONT	10
- 1	1	1	1	318707-1	FLOATING SHEAR, FRONT	9
1	1	1	1	1-1803249-9	ANVIL, COMBINATION	8
- -	-	-	-	-	-	7
- -	-	-	-	-	-	6
- 1	1	1	1	2119757-5	DEPRESSOR, SHEAR	5
- 1	1	1	1	238011-3	BLOCK, CRIMPER SPACER	4
1	1	1	1	5-1803187-1	CRIMPER, INSULATION F	3
- 1	1	1	1	1-455888-4	SPACER, CRIMPER	2
1	1	1	1	3-1803188-9	CRIMPER, WIRE	1

DIMENSIONS:		TOLERANCES UNLESS OTHERWISE SPECIFIED:		MATERIAL:		FINISH:		WEIGHT:		SCALE:	
mm	0 PLC ±	1 PLC ±	2 PLC ±	3 PLC ±	4 PLC ±	ANGLES	FINISH	Customer Accessible Production Drawing	SCALE	1:2	SHEET 1 of 4

LOC	DIST	REV	DATE	BY	APPV
A	66				

FEED TYPE

PNEUMATIC

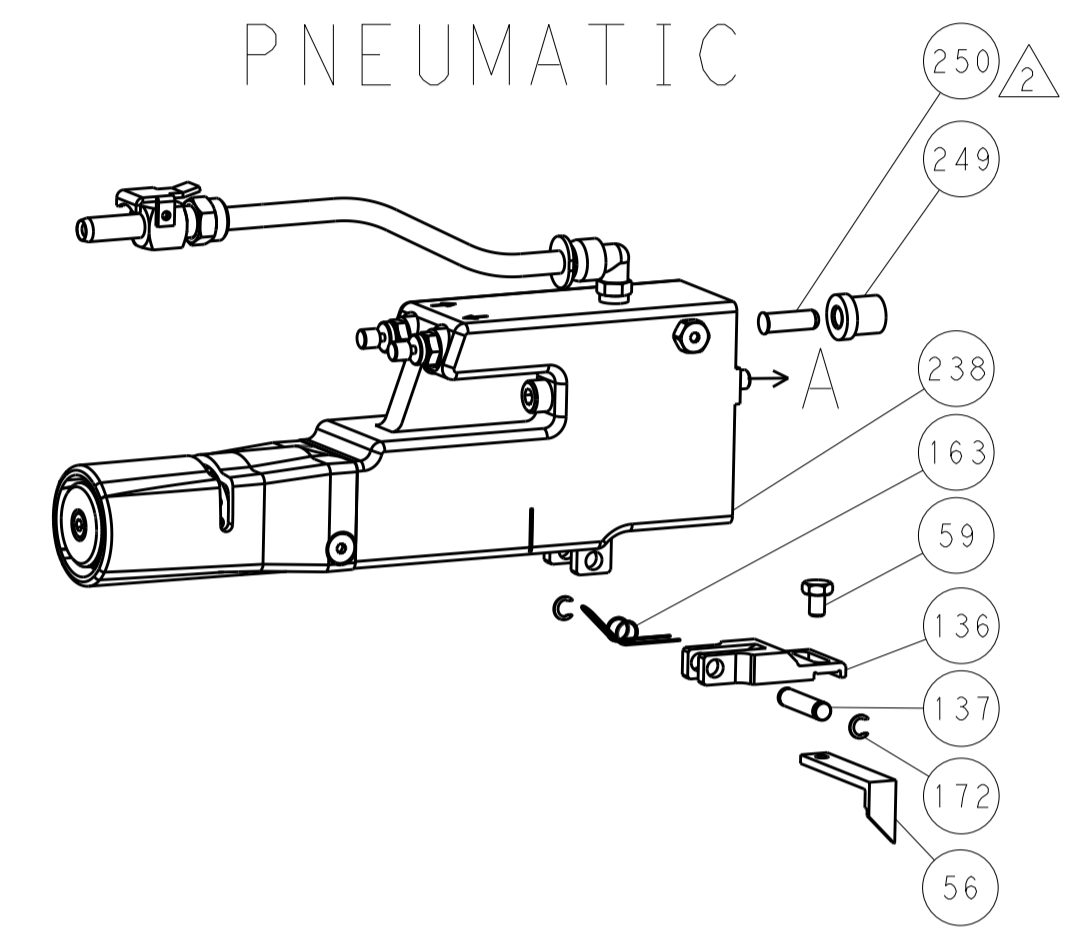

SERVO LATCH PLATE



CAM POSITION

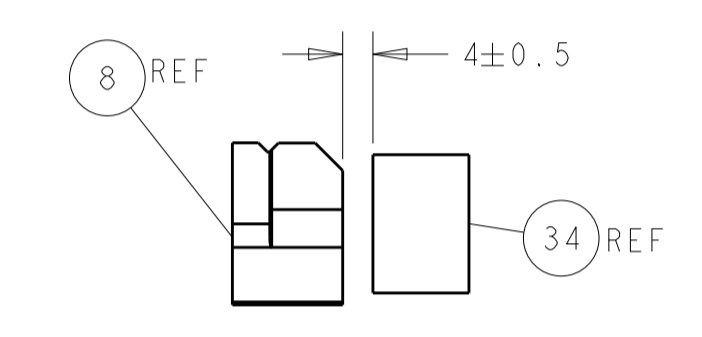
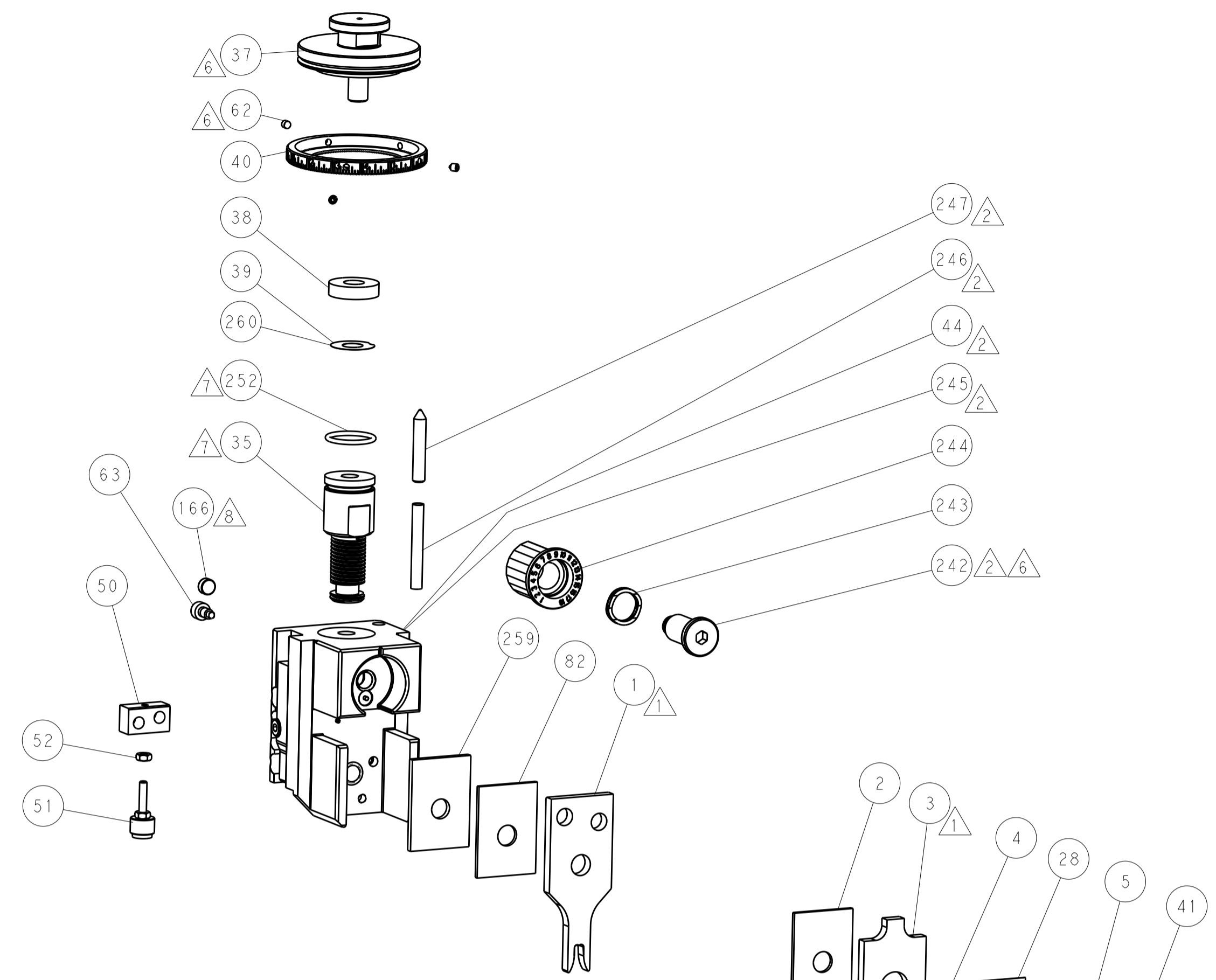

TERMINAL SUPPORT LOCATION

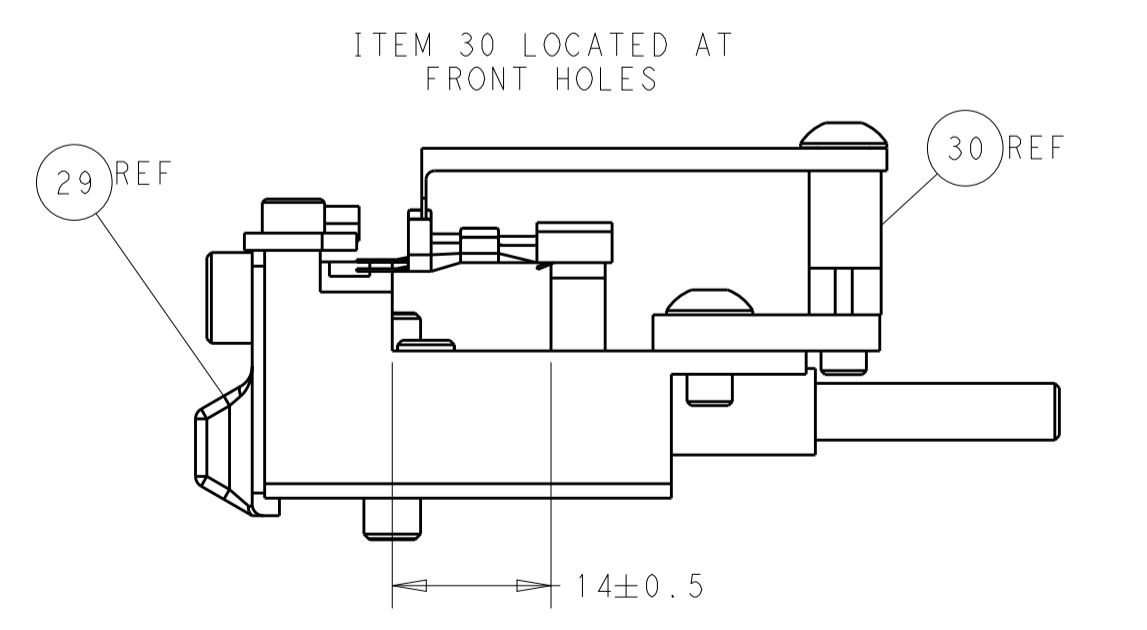
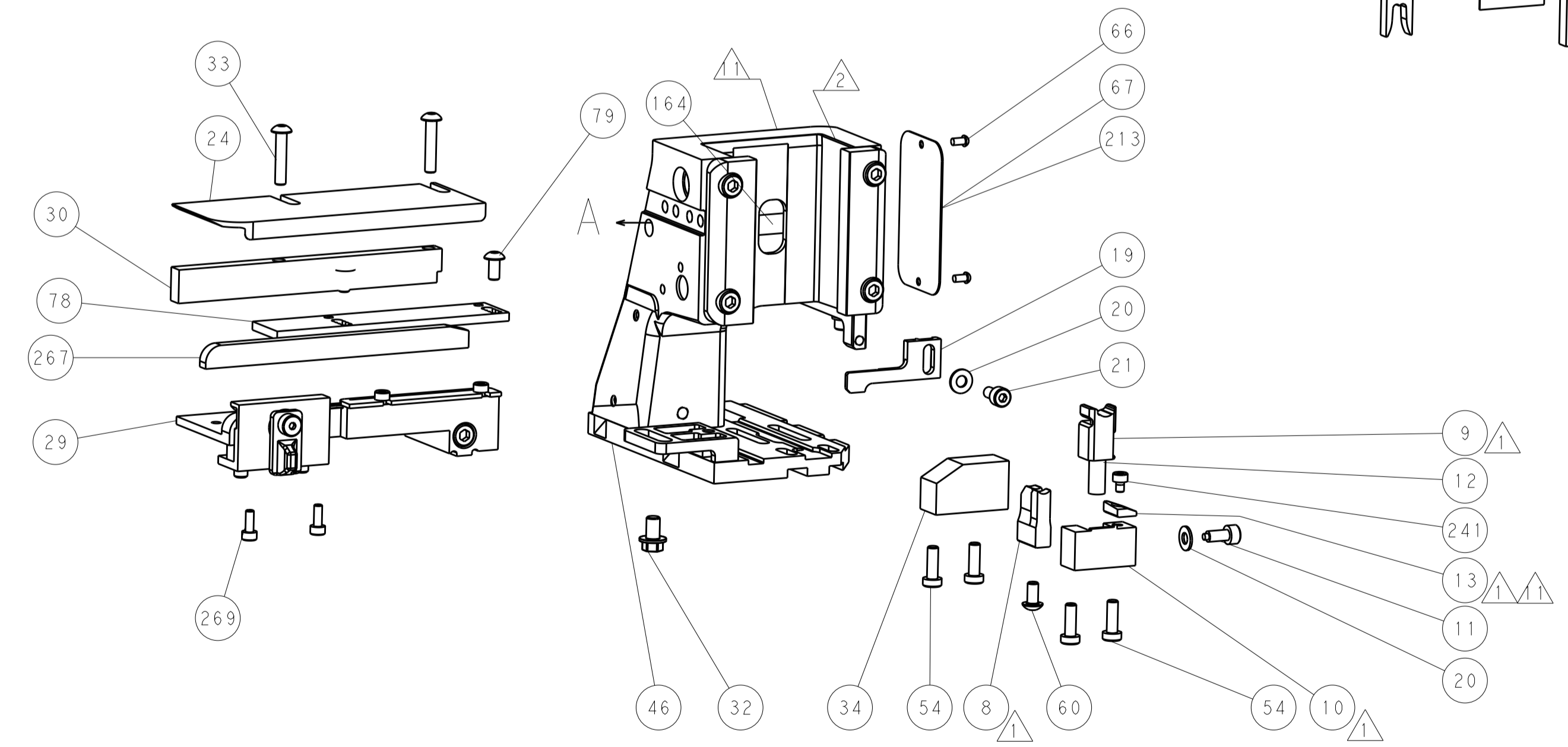

FEED TRACK POSITION GUIDE BY INSULATION BARREL

ATLANTIC VERSION
 Shown on sheets 1 of 4 & 2 of 4
 (Pacific version shown on sheets 3 of 4 & 4 of 4)

DIMENSIONS:		TOLERANCES UNLESS OTHERWISE SPECIFIED:		DWG: B. WEAVER 28SEP2015		TE Connectivity	
mm	0 PLC ±	1 PLC ±	2 PLC ±	3 PLC ±	4 PLC ±	ANGLES ±	TE Connectivity Harrisburg, PA 17105-3608
MATERIAL:	FINISH:	WEIGHT:	SCALE:	SIZE:	CAGE CODE:	DRAWING NO:	RESTRICTED TO:
			1:2	A1	00779	©=2266997	
Customer Accessible Production Drawing				SHEET 2 OF 4		REV A	

PACIFIC VERSION TERMINATOR INTERFACE ADAPTER	PART NUMBER	REVISION	DESCRIPTION	FEED TYPE	CONVERT TO	PART NUMBERS REQUIRED					
	2-2266997-2	A	FINE CRIMP HEIGHT ADJUST	PNEUMATIC	-	-	-	-	-	-	
	2-2266997-5	A	FINE CRIMP HEIGHT ADJUST	SERVO LATCH PLATE ⁴	SERVO LATCH PLATE	2119951-1	-	8-2266997-5	1901094-3	-	2168400-6 (QUANTITY 2)
	2-2266997-7	A	FINE CRIMP HEIGHT ADJUST	NONE	SMART APPLICATOR	2161326-1	-	8-2266997-4	-	-	
	7-2266997-7	A	CRIMP TOOLING KIT	-	PNEUMATIC FEED	2119950-1	1338683-8	5-18022-5	2119641-2	2119799-1	2063440-1

APPLICATOR DATA		
CRIMP	SIZE	TYPE
WIRE	3.96 mm [1.56]	F
INSUL	5.54 mm [2.18]	F
APPLICATOR INSTRUCTIONS 408-10389		

TERMINAL DATA: KET TERMINAL		KET CRIMP SPECIFICATION	
TERMINAL NAME: TERMINAL, 6.4 EARTH RING			
WIRE STRIP LENGTH		INSULATION DIAMETER RANGE	
5.72-6.48 mm [1.225-.255 IN]		Ø1.60-2.90 mm [1.063-.114 IN]	
TERMINAL APPLICATION SPECIFICATION	KET Rev -	-	-
TERMINALS APPLIED ¹⁰			
TE TERMINAL	KET TERMINAL	TE TERMINAL	KET TERMINAL
2113860-1	ST710965-1	2113860-2	ST710965-3

WIRE SIZE	CRIMP HEIGHT mm [INCH]	CRIMP HEIGHT REFERENCE SETTING ⁹
AVSS 0.85 + 0.5	2.15+/-0.05 [1.085+/-0.02]	7.7
AVSS 1.25	2.10+/-0.05 [1.083+/-0.02]	7.5
AVSS 0.5 + 0.5	2.05+/-0.05 [1.081+/-0.02]	8.6
AVSS 0.85	1.95+/-0.05 [1.077+/-0.02]	9.3
AVSS 0.5	1.85+/-0.05 [1.073+/-0.02]	10.3

- RECOMMENDED SPARE PARTS
- ² GREASE BEARING SURFACES LIGHTLY
- 3. LUBRICATE DAILY PER THE APPLICATOR INSTRUCTION SHEET SUPPLIED WITH THE APPLICATOR.
- ⁴ APPLICATOR SPECIFIC DATA TO BE ENTERED INTO BLANK MEMORY CHIP AT ASSEMBLY. SEE BELOW FOR PART NUMBER:
PNEUMATIC FEED WITH "SMART APPLICATOR" CONVERSION: 8-2266997-4
SERVO FEED WITH "FINE CRIMP HEIGHT ADJUST": 8-2266997-5
- 5. ADJUSTMENT OF THE STRIPPER MAY BE REQUIRED WHEN MOVING THE APPLICATOR BETWEEN BENCH AND LEADMAKER APPLICATIONS.
- ⁶ APPLY PART NUMBER 1-23419-5 LOCTITE TO THREADS OF ITEM 62.
APPLY PART NUMBER 2-23419-6 LOCTITE TO THREADS OF ITEM 242.
- ⁷ GREASE THREADS, GROOVE AND O-RING ON ITEMS 139 & 152.
- ⁸ MAGNET MUST BE ORIENTED CORRECTLY IN ORDER TO PROPERLY ACTUATE THE COUNTER.
- ⁹ CRIMP HEIGHT REFERENCE SETTING WAS THE SETTING USED WHEN THE APPLICATOR WAS QUALIFIED AT THE FACTORY. ADJUSTMENT MAY BE NECESSARY WHEN RUNNING APPLICATOR IN THE FIELD.
- ¹⁰ TERMINAL PITCH NOT COMPATIBLE WITH MECHANICAL FEED.
- ¹¹ TO CONVERT THE APPLICATOR TO A NON-CARRIER CUTTING STYLE, REMOVE ITEM 13 AND ATTACH TO THE LOCATION ON BACK SIDE OF THE HOUSING. REFER TO INSTRUCTION SHEET FOR ADDITIONAL INFORMATION.

***WARNING**
ON INSTALLATION, SET WIRE DISC, ITEM 40 TO LARGEST WIRE SIZE SETTING. USE OF SETTINGS BELOW MINIMUM REQUIRED CRIMP HEIGHT SETTING WILL CAUSE DAMAGE TO CRIMP TOOLING.

-77	-27	-25	-22	PART NO	DESCRIPTION	ITEM NO
-	2	2	2	2168083-1	SCR, SKT HD CAP, RoHS, M3 X 8.0	269

PACIFIC VERSION
Shown on sheets 3 of 4 & 4 of 4
(Atlantic version shown on sheets 1 of 4 & 2 of 4)

SET UP GAUGE	LOC	DIST	REVISIONS			
2119599-1	A	66	REV	DATE	BY	APPV
			-	SEE SHEET 1	-	-

-	1	1	1	1-1633782-2	FENCE	267
-	1	1	1	1803078-2	SPACER, PRECISION	259
-	1	1	1	2119782-1	FINE ADJUST HEAD ASM, PACIFIC STYLE	251
-	-	-	1	2119640-1	PUSH ROD, AIR FEED	250
-	-	-	1	2079988-1	BUSHING, LCH5-12, MISUMI	249
-	1	1	1	1-22279-3	SPRING, COMPRESSION	246
-	1	1	1	2119082-8	CAM, SNAIL, INSULATION ADJUSTMENT	244
-	1	1	1	2079764-1	WASHER, WAVE SPRING, CREST-TO-CREST	243
-	1	1	1	2119083-1	RETAINER, INSULATION DIAL	242
-	1	1	1	7-18023-7	SCR, SKT HD CAP M3 X 4.0	241
-	-	2	-	2168400-6	SHCS, LOW HEAD, RoHS, M5 X 16	240
-	-	-	1	2063440-1	AIR FEED MODULE	238
-	-	1	-	2119740-2	TAG, IDENTIFICATION	213
-	-	1	-	1901094-3	SPACER, FEEDER	198
-	-	-	2	21045-3	RING, RETAIN, EXTERN, 3/16 CRESCENT	172
-	1	1	1	994969-1	MAGNET, RARE EARTH HIGH ENERGY	166
-	REF	REF	REF	994970-2	COUNTER, MAGNETIC	164
-	-	-	1	240638-1	SPRING, FEED FINGER	163
-	1	1	1	8-21084-1	O-RING, .801 ID, .070 DIA. MAT.	152
-	-	-	1	2119641-2	FEED CAM, AIR FEED	151
-	1	1	1	2119798-2	DETENT PIN	145
-	1	1	1	2079383-8	SCR, BHSC, RoHS (M4 X 16)	144
-	4	4	4	2168400-5	SHCS, LOW HEAD, RoHS, M4 X 20	143
-	1	1	1	1-2119656-0	APPLICATOR BASIC ASSEMBLY, SF	141
-	1	1	1	2161312-1	RAM, STEPPED, ASIAN STYLE, SIDE FEED	140
-	1	1	1	2119092-2	BOLT, ADJUSTMENT	139
-	-	-	1	3-23627-7	PIN, RETAIN, GRVD, 3/16 X .854	137
-	-	-	1	2119799-1	HOLDER, FEED FINGER, AF	136
-	-	REF	-	SEE NOTE 4	MEMORY CHIP, PROGRAMMED	135
-	-	1	-	1633743-1	SERVO FEED LATCH ASM	133
-	-	REF	-	2119944-1	FEED FINGER ASSEMBLY, SF	117
-	1	1	1	1-455888-4	SPACER, CRIMPER	82
-	2	2	2	2079383-4	SCR, BHSC, RoHS (M4 X 8)	79
-	1	1	1	1803096-1	EXTENSION PLATE	78
-	1	1	1	2119956-1	DOCUMENTATION PACKAGE	71
-	1	-	1	2119740-1	TAG, IDENTIFICATION	67
-	2	2	2	2168078-1	SCREW, DRIVE, RH, RoHS, 2 x .188	66
-	1	1	1	2119793-1	LIMITER, ADJUSTMENT BOLT	63
-	3	3	3	992763-5	SCR, SET, SOC, CONE POINT, M3 X 4.0	62
-	-	-	1	5-18022-5	SCR, HEX HD CAP, M4 X 6.0	59
-	-	-	1	1338683-8	FEED PAWL	56
-	2	2	2	1-2168083-0	SCR, SKT HD CAP, RoHS, M4 X 10	53
-	1	1	1	5018030-1	NUT, HEX, REG, RoHS, M3	52
-	1	1	1	811242-5	BUMPER, HOLD DOWN	51
-	1	1	1	690753-2	SPACER, TONKER	50
-	-	-	1	18023-9	SCR, SKT HD CAP M4 X 6.0	49
-	1	1	1	1-2079383-5	SCR, BHSC, RoHS (M8 X 40)	41
-	1	1	1	2119645-1	DISC, NUMBERED FA WIRE ADJUSTMENT	40
-	1	1	1	2119957-1	APPLICATOR SHIM PACK	39
-	1	1	1	2119644-2	RAM WASHER, PRECISION	38
-	1	1	1	1752356-4	SUPPORT, TERMINAL	34
-	2	2	2	2079383-5	SCR, BHSC, RoHS (M4 X 20)	33
-	1	1	1	2161328-1	HEX HEAD, FLANGED, M5 x 8mm LONG	32
-	1	1	1	1320908-1	SPACER, STRIP GUIDE	30
-	1	1	1	2119959-1	ASSEMBLY, STRIP GUIDE	29
-	1	1	1	455888-3	SPACER, CRIMPER	28
-	1	1	1	1320928-4	STRIP GUIDE	24
-	1	1	1	2168083-2	SCR, SKT HD CAP, RoHS, M4 X 8.0	21
-	2	2	2	1-18028-2	WASHER, FLAT, REG M4	20
-	1	1	1	2119533-1	STRIPPER, SIDE FEED	19
-	1	1	1	2119806-1	INSERT, SHEAR	13
-	1	1	1	3-22280-3	SPRING, COMPRESSION	12
-	1	1	1	1-356885-4	STOP, SHEAR	11
-	1	1	1	2119805-1	SHEAR HOLDER, FRONT	10
-	1	1	1	318707-1	FLOATING SHEAR, FRONT	9
-	1	1	1	1-1803249-9	ANVIL, COMBINATION	8
-	-	-	-	-	-	7
-	-	-	-	-	-	6
-	1	1	1	2119757-5	DEPRESSOR, SHEAR	5
-	1	1	1	238011-3	BLOCK, CRIMPER SPACER	4
-	1	1	1	5-1803187-1	CRIMPER, INSULATION F	3
-	1	1	1	1-455888-4	SPACER, CRIMPER	2
-	1	1	1	3-1803188-9	CRIMPER, WIRE	1

DIMENSIONS:		TOLERANCES UNLESS OTHERWISE SPECIFIED:		DWG		REV		DATE		BY		APPV	
mm	0 PLC	±		WEAVER	28SEP2015								
	1 PLC	±		T. ELBIN	28SEP2015								
	2 PLC	±											
	3 PLC	±											
	4 PLC	±											
	ANGLES	±											
	FINISH	±											



TE Connectivity
Harrisburg, PA 17105-3608

Ocean Side Feed
Applicator

Customer Accessible Production Drawing SCALE 1:2 SHEET 3 OF 4 REV A

