

PART NUMBER	REVISION	DESCRIPTION	FEED TYPE
2266538-2	B	FINE CRIMP HEIGHT ADJUST	PNEUMATIC
7-2266538-2	B	PNEUMATIC AND CRIMP TOOLING KIT	PNEUMATIC
7-2266538-7	A	CRIMP TOOLING KIT	-

ATLANTIC VERSION TERMINATOR INTERFACE ADAPTER

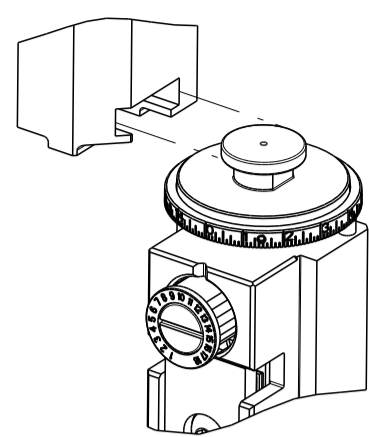

APPLICATOR DATA		
CRIMP	SIZE	TYPE
WIRE	5.93 mm [.233]	F
INSUL	8.23 mm [.324]	F

APPLICATOR INSTRUCTIONS 408-35042

TERMINAL DATA: MTA TERMINAL		MTA CRIMP SPECIFICATION	
TERMINAL NAME: TERMINAL			
WIRE STRIP LENGTH 7.32-8.08 mm [.288-.318 IN]		INSULATION DIAMETER RANGE Ø5.50-6.90 mm [.217-.272 IN]	
TERMINAL APPLICATION SPECIFICATION B0-018.004A Rev 10			
TERMINALS APPLIED			
TE TERMINAL 2113603-1	MTA TERMINAL 1707670	TE TERMINAL 2113667-1	MTA TERMINAL 1707672

WIRE SIZE	CRIMP HEIGHT mm [INCH]	CRIMP HEIGHT REFERENCE SETTING
10.00mm2	3.50 +/- 0.05 [.138 +/- .002]	3.5
8.00mm2	3.10 +/- 0.05 [.122 +/- .002]	8.2

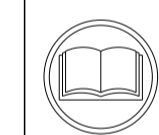

- 1 RECOMMENDED SPARE PARTS
- 2 REFER TO SUPPLIED INSTRUCTION SHEET FOR CLEANING, LUBRICATION AND STORAGE OF APPLICATOR.
- 3 APPLY PART NUMBER 2-23419-6 LOCTITE TO THREADS OF ITEM 242.
- 4 CRIMP HEIGHT REFERENCE SETTING WAS THE SETTING USED WHEN THE APPLICATOR WAS QUALIFIED AT THE FACTORY. ADJUSTMENT MAY BE NECESSARY WHEN RUNNING APPLICATOR IN THE FIELD.
- 5 TERMINAL PITCH NOT COMPATIBLE WITH MECHANICAL FEED.
- 6 UNLESS SPECIFIED OTHERWISE TORQUE VALUES SHALL BE USED PER DOCUMENT, 101-35000.
- 7 NOT RECOMMENDED FOR ALL PRESSES. CHECK PRESS COMPATIBILITY FOR WIRE SIZE AND OUTPUT FORCE.

***WARNING**
ON INSTALLATION, SET WIRE DISC TO CRIMP HEIGHT REFERENCE SETTING FOR LARGEST WIRE SIZE. CRIMP HEIGHT REFERENCE SETTINGS GREATER THAN THE VALUE SHOWN MAY CAUSE DAMAGE TO THE CRIMP TOOLING. REFER TO THE INSTRUCTION SHEET FOR PROPER SETUP AND ADJUSTMENTS.

ATLANTIC VERSION
Shown on sheets 1 of 4 & 2 of 4
(Pacific version shown on sheets 3 of 4 & 4 of 4)

LOC	DIST	REVISIONS					
		P	LTN	DESCRIPTION	DATE	OWN	APVD
A	66	A		RELEASED	11FEB2015	BW	TE
		B		ECR-20-016528	19NOV2020	TB	RR

-	2	2	2168083-1	SCR, SKT HD CAP, RoHS, M3 X 8.0	269	
-	1	1	1633782-6	FENCE	267	
-	1	1	1803078-2	SPACER, PRECISION	259	
-	1	1	2119641-1	FEED CAM, AIR FEED	248	
-	1	1	2119082-5	CAM, SNAIL, INSULATION ADJUSTMENT	244	
-	1	1	2079764-1	WASHER, WAVE SPRING, CREST-TO-CREST	243	
-	1	1	2119083-1	RETAINER, INSULATION DIAL	242	
-	1	1	7-18023-7	SCR, SKT HD CAP M3 X 4.0	241	
-	-	-	2119580-1	MECHANICAL FEED ASSEMBLY	239	
-	1	1	2844940-2	AIR FEED MODULE	238	
-	REF	REF	994970-2	COUNTER, MAGNETIC	164	
-	1	1	2844908-1	SCREW, LOCKING	99	
-	1	1	2844907-1	POST, LOCKING	98	
-	1	1	1-690438-0	FRONT STRIP GUIDE	96	
-	1	1	318563-1	GUARD, FRONT CHIP	89	
-	1	1	455888-9	SPACER, CRIMPER	82	
-	2	2	2079383-4	SCR, BHSC, RoHS (M4 X 8)	79	
-	1	1	1803096-1	EXTENSION PLATE	78	
-	1	1	1803607-3	DOCUMENTATION PACKAGE	71	
-	1	1	2119740-1	TAG IDENTIFICATION	67	
-	2	2	2168078-1	SCREW, DRIVE, RH, RoHS, 2 x .188	66	
-	1	1	2168083-2	SCR, SKT HD CAP, RoHS, M4 X 8.0	60	
-	1	1	5-18022-5	SCR, HEX HD CAP, M4 X 6.0	59	
-	1	1	1-1338683-1	FEED PAWL	56	
-	4	4	2168083-3	SCR, SKT HD CAP, RoHS, M4 X 12.0	54	
-	2	2	1-2168083-0	SCR, SKT HD CAP, RoHS, M4 X 10	53	
-	1	1	5018030-1	NUT, HEX, REG, RoHS, M3	52	
-	1	1	811242-5	BUMPER, HOLD DOWN	51	
-	1	1	690753-2	SPACER, TONKER	50	
-	1	1	18023-9	SCR, SKT HD CAP M4 X 6.0	49	
-	-	-	2119652-1	FEED CAM, PRE FEED	48	
-	-	-	2119653-1	FEED CAM, POST FEED	47	
-	1	1	1-1803583-7	APPLICATOR BASIC ASSEMBLY, SF	46	
-	1	1	1803515-2	RAM ASSEMBLY, SF ATLANTIC	44	
-	1	1	1803602-2	SCR, BHSC, RoHS (M8 X 40)	41	
-	1	1	1752356-1	SUPPORT, TERMINAL	34	
-	2	2	2079383-5	SCR, BHSC, RoHS (M4 X 20)	33	
-	2	2	3-2844962-0	SPACER, CYLINDRICAL, STRIP GUIDE	30	
-	1	1	2844992-5	ASSEMBLY, STRIP GUIDE	29	
-	1	1	455888-3	SPACER, CRIMPER	28	
-	2	2	22281-8	SPRING, COMPRESSION	27	
-	1	1	240792-1	DRAG, TERMINAL	25	
-	1	1	1320928-6	STRIP GUIDE	24	
-	1	1	2168083-2	SCR, SKT HD CAP, RoHS, M4 X 8.0	21	
-	1	1	1-18028-2	WASHER, FLAT, REG M4	20	
-	1	1	2119533-1	STRIPPER, SIDE FEED	19	
-	1	1	2119806-1	INSERT, SHEAR	13	
-	1	1	3-22280-3	SPRING, COMPRESSION	12	
-	1	1	1-356885-3	STOP, SHEAR	11	
-	1	1	2119805-3	SHEAR HOLDER, FRONT	10	
-	1	1	318059-1	FLOATING SHEAR, FRONT	9	
-	1	2	1	2-1633930-8	ANVIL, COMBINATION	8
-	-	-	-	-	7	
-	-	-	-	-	6	
-	1	1	1803080-1	DEPRESSOR, SHEAR	5	
-	1	1	5-238011-7	BLOCK, CRIMPER SPACER	4	
-	1	2	1	8-1633961-7	CRIMPER, INSULATION F PREMIUM	3
-	1	1	1	1-455888-6	SPACER, CRIMPER	2
-	1	2	1	8-1633664-2	CRIMPER, WIRE	1

DIMENSIONS:		TOLERANCES UNLESS OTHERWISE SPECIFIED:		MATERIAL:		FINISH:		WEIGHT:		SCALE:	
mm	0 PLC ±	1 PLC ±	2 PLC ±	3 PLC ±	4 PLC ±	ANGLES	FINISH	Customer Accessible Production Drawing	SCALE	1:2	SHEET 1 of 4

LOC	DIST	REVISIONS					
A	66	P	LTH	DESCRIPTION	DATE	OWN	APVD
		-		SEE SHEET 1	-	-	-

FEED TYPE

PNEUMATIC

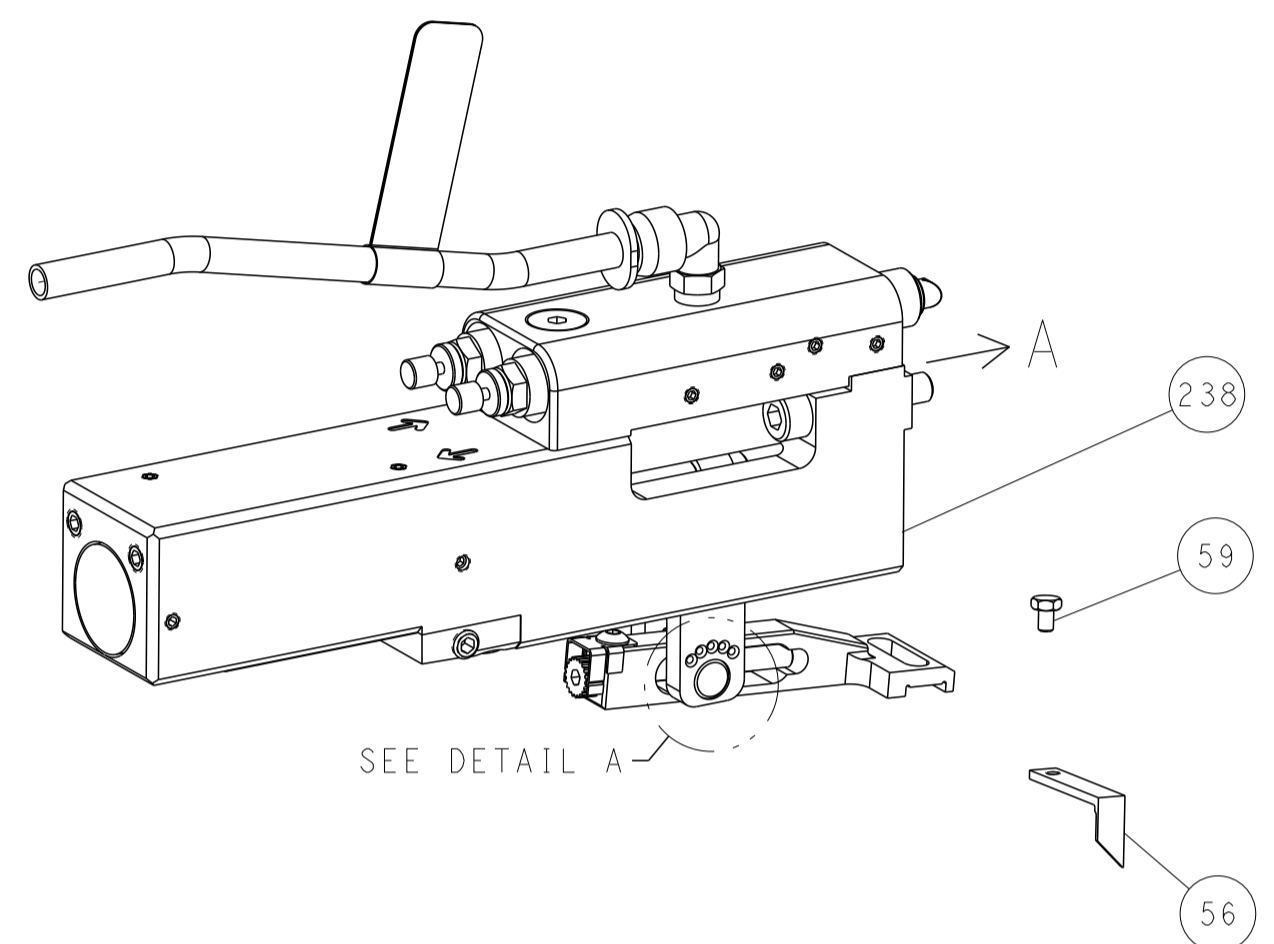

SEE DETAIL A

FEED SPRING SETTING POSITION (SHOWN FROM REAR SIDE)

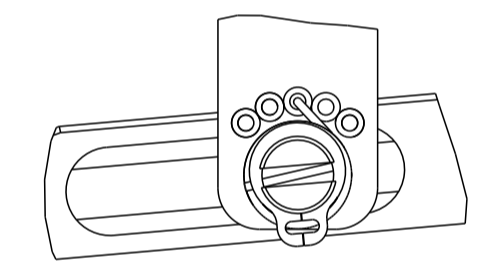

DETAIL A

CAM POSITION

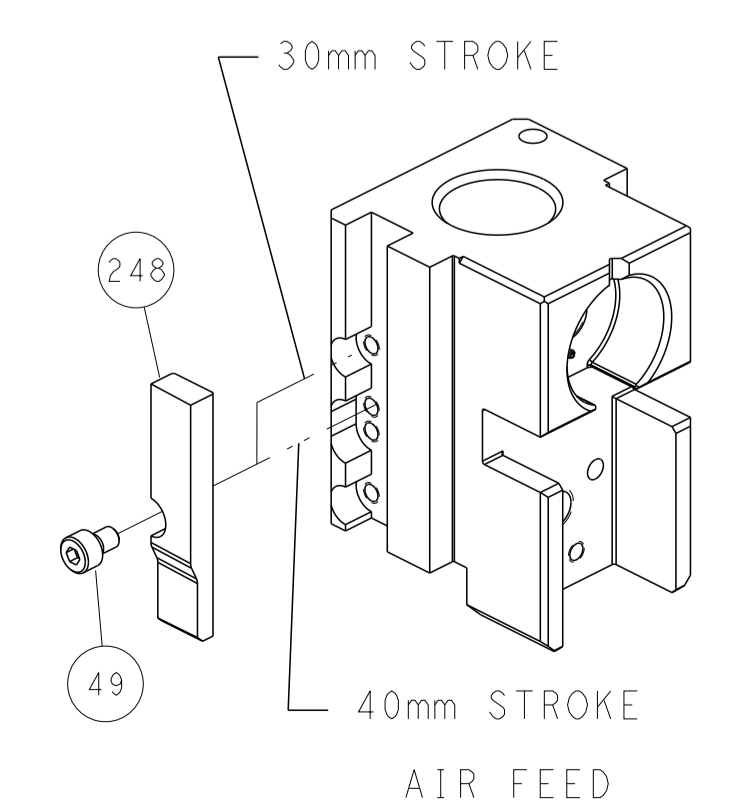

AIR FEED

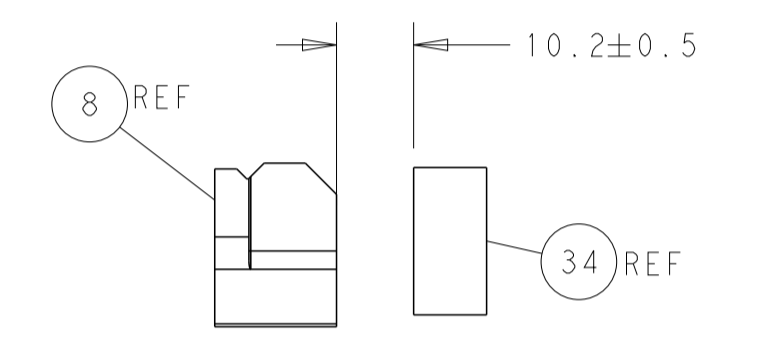
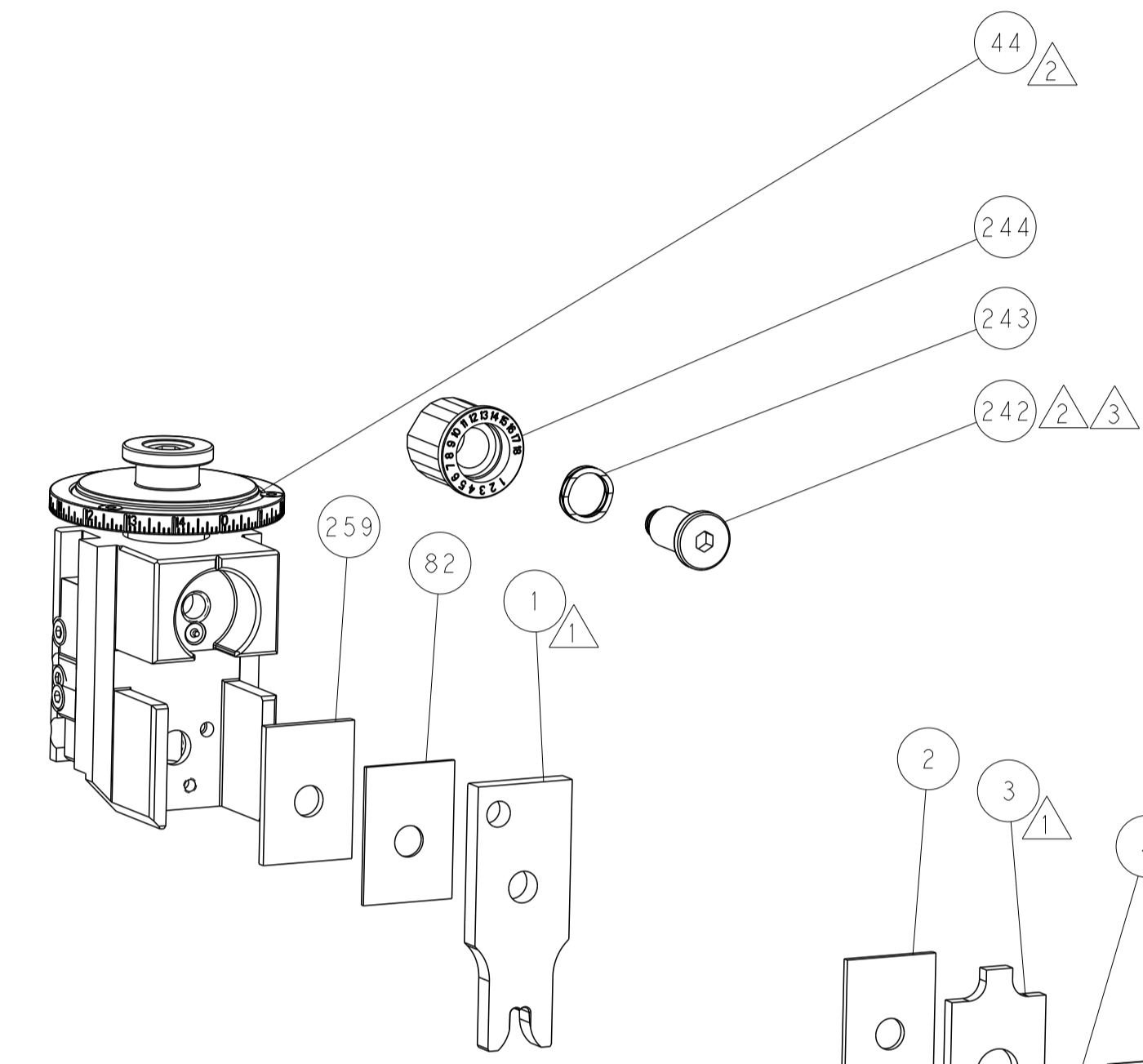
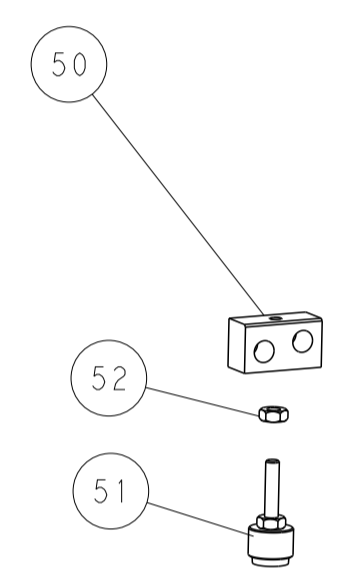
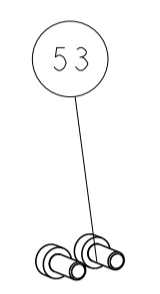

TERMINAL SUPPORT LOCATION

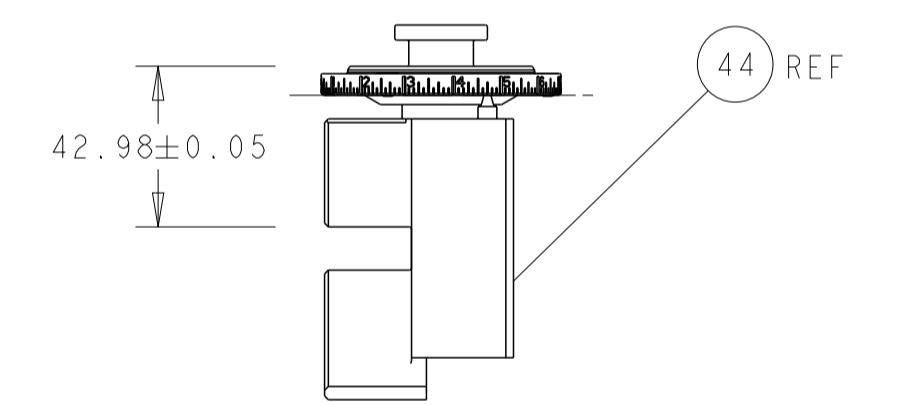

RAM SET-UP

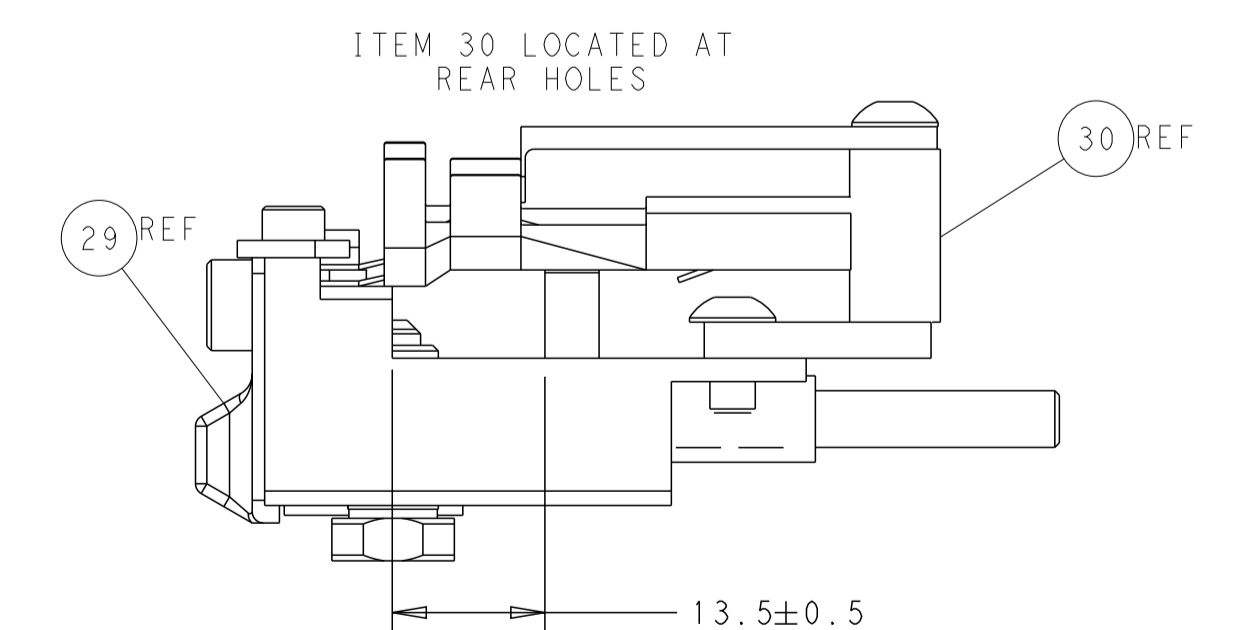
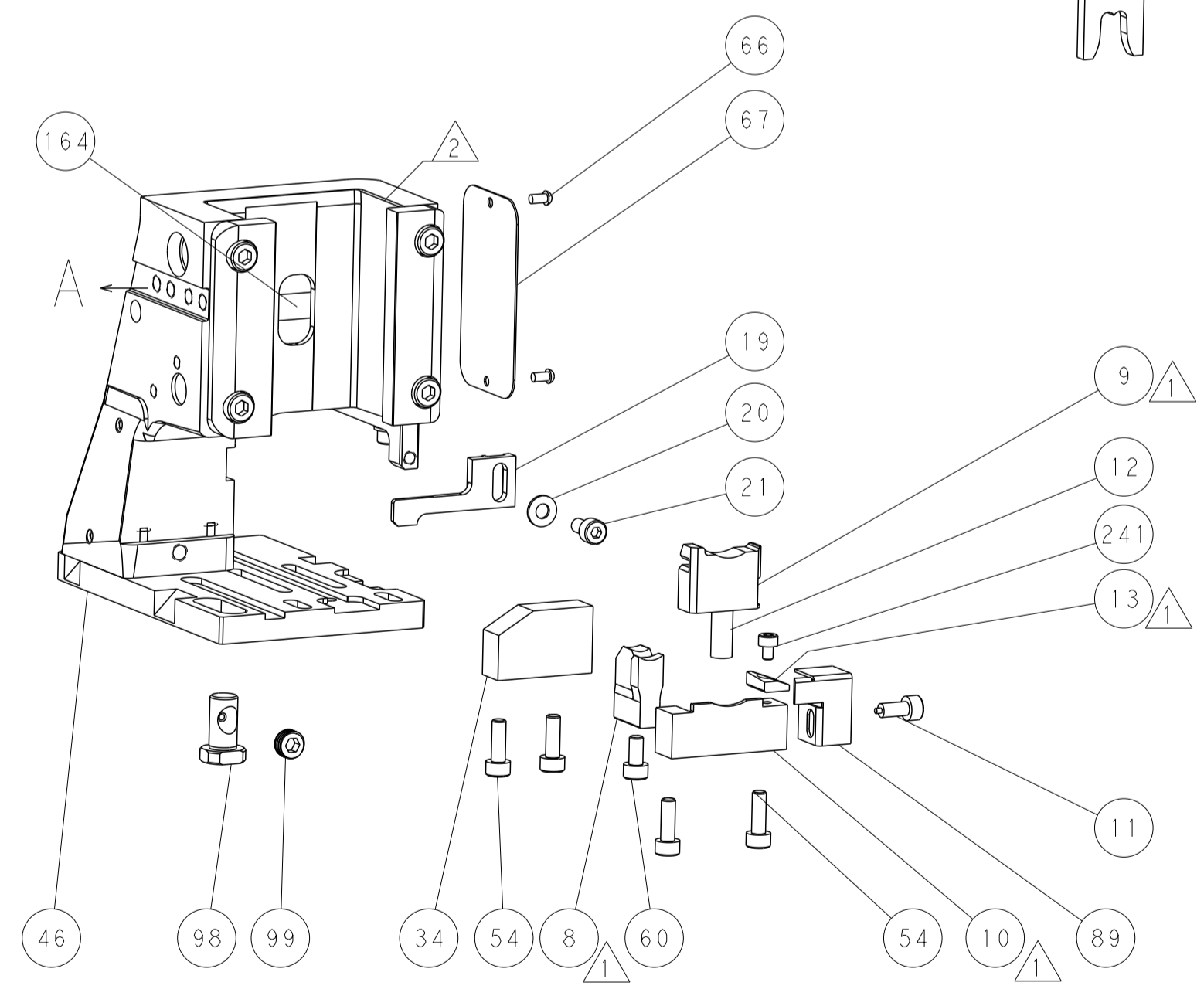
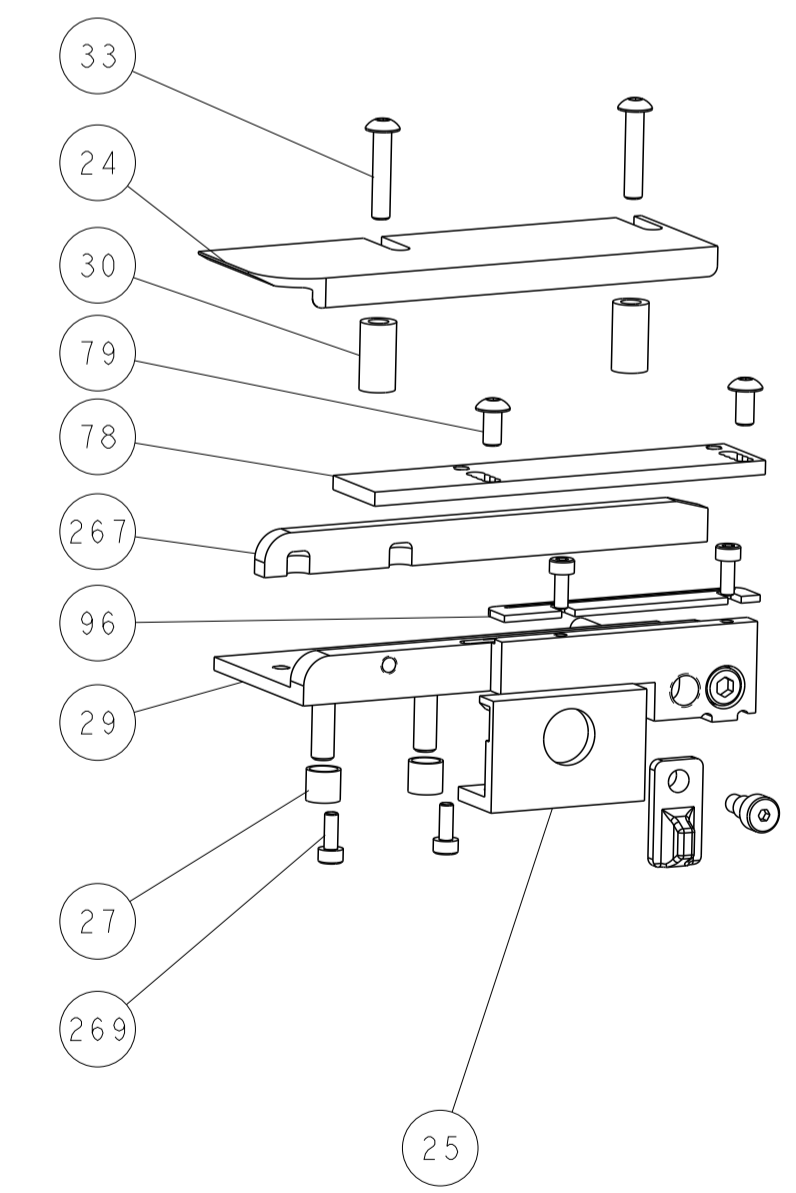

FEED TRACK POSITION GUIDE BY WIRE BARREL

ATLANTIC VERSION
 Shown on sheets 1 of 4 & 2 of 4
 (Pacific version shown on sheets 3 of 4 & 4 of 4)

DIMENSIONS:		TOLERANCES UNLESS OTHERWISE SPECIFIED:		DWG: B. WEAVER 13OCT2014		TE Connectivity	
mm	0 PLC ±	1 PLC ±	2 PLC ±	3 PLC ±	4 PLC ±	Harrisburg, PA 17105-3608	
	ANGLES ±	FINISH ±		APVD: T. ELBIN 13OCT2014	NAME: Ocean Side Feed Applicator		
MATERIAL:				PRODUCT SPEC:	SIZE: A1	CAGE CODE: 00779	DRAWING NO: 2266538
				APPLICATION SPEC:	WEIGHT:	SCALE: 1:2	SHEET 2 OF 4
					Customer Accessible Production Drawing	REV: B	

LOC	DIST	REVISIONS					
A	66	P	LTN	DESCRIPTION	DATE	DWN	APVD
		-		SEE SHEET 1	-	-	-

FEED TYPE

PNEUMATIC

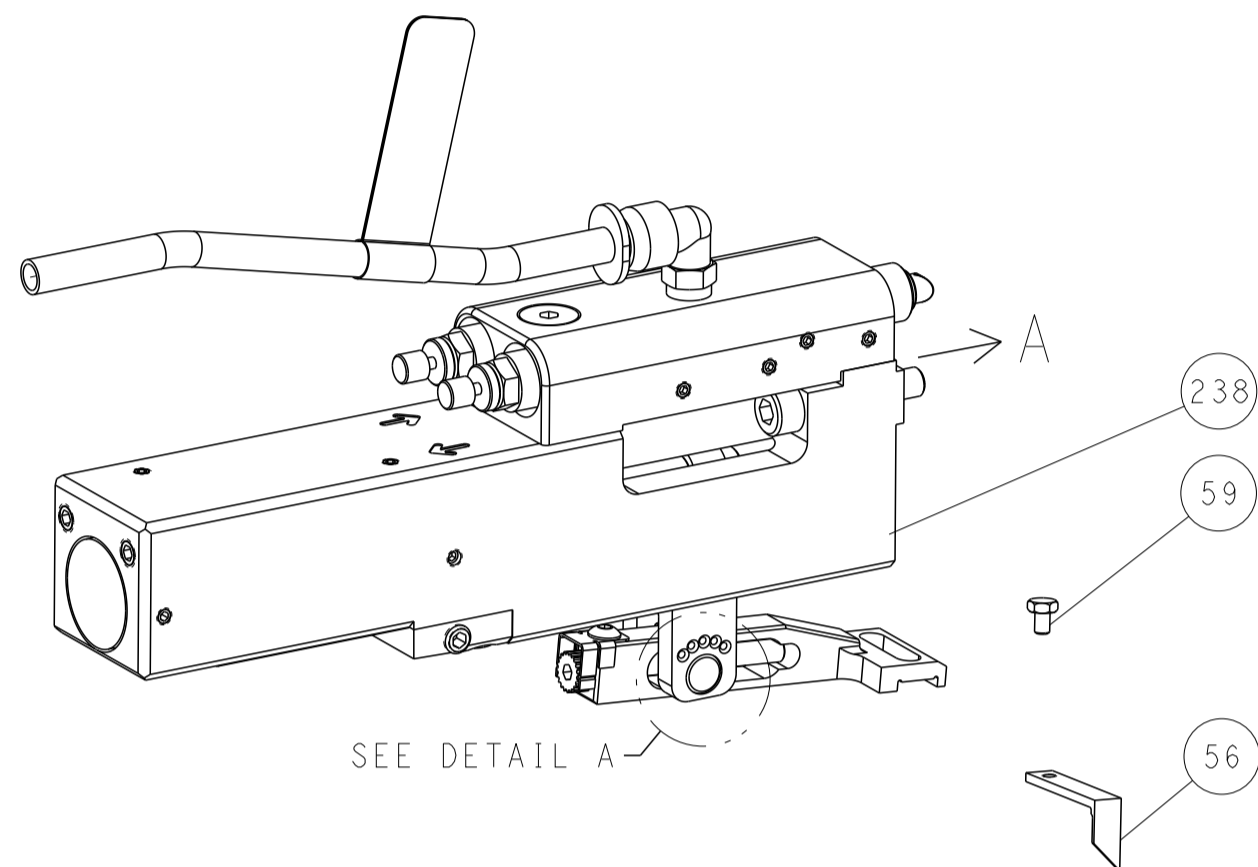

SEE DETAIL A

FEED SPRING SETTING POSITION (SHOWN FROM REAR SIDE)

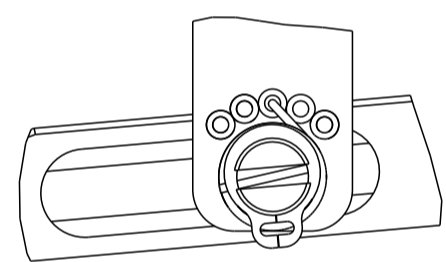

DETAIL A

CAM POSITION

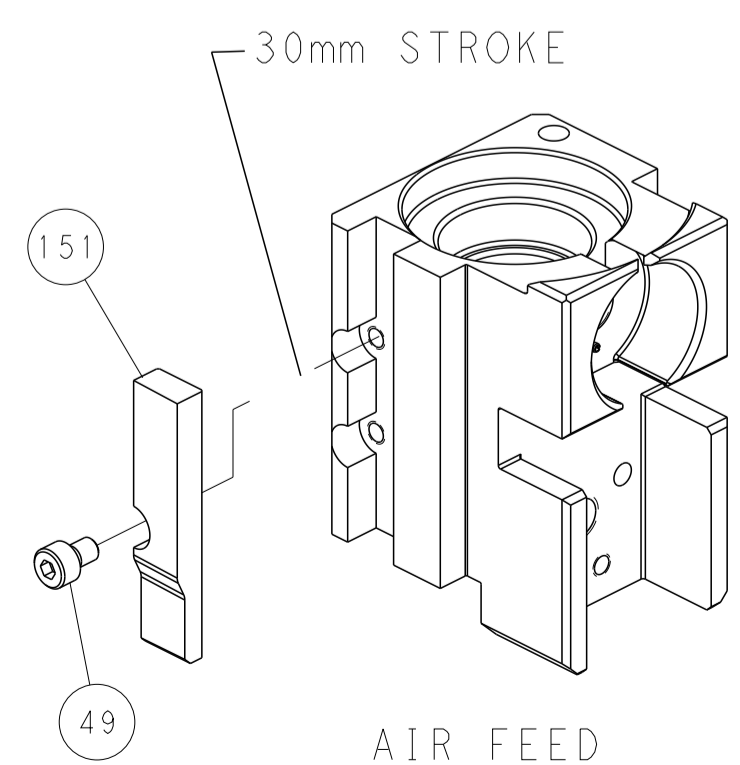

AIR FEED

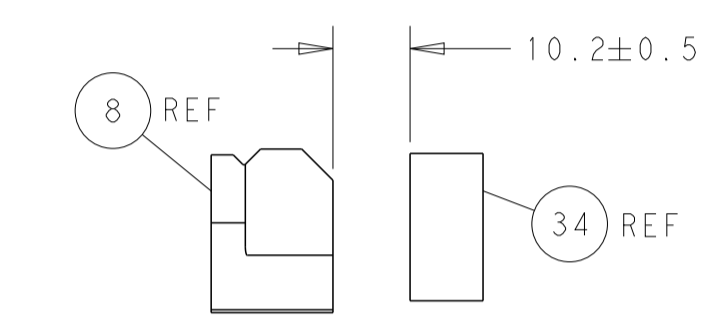
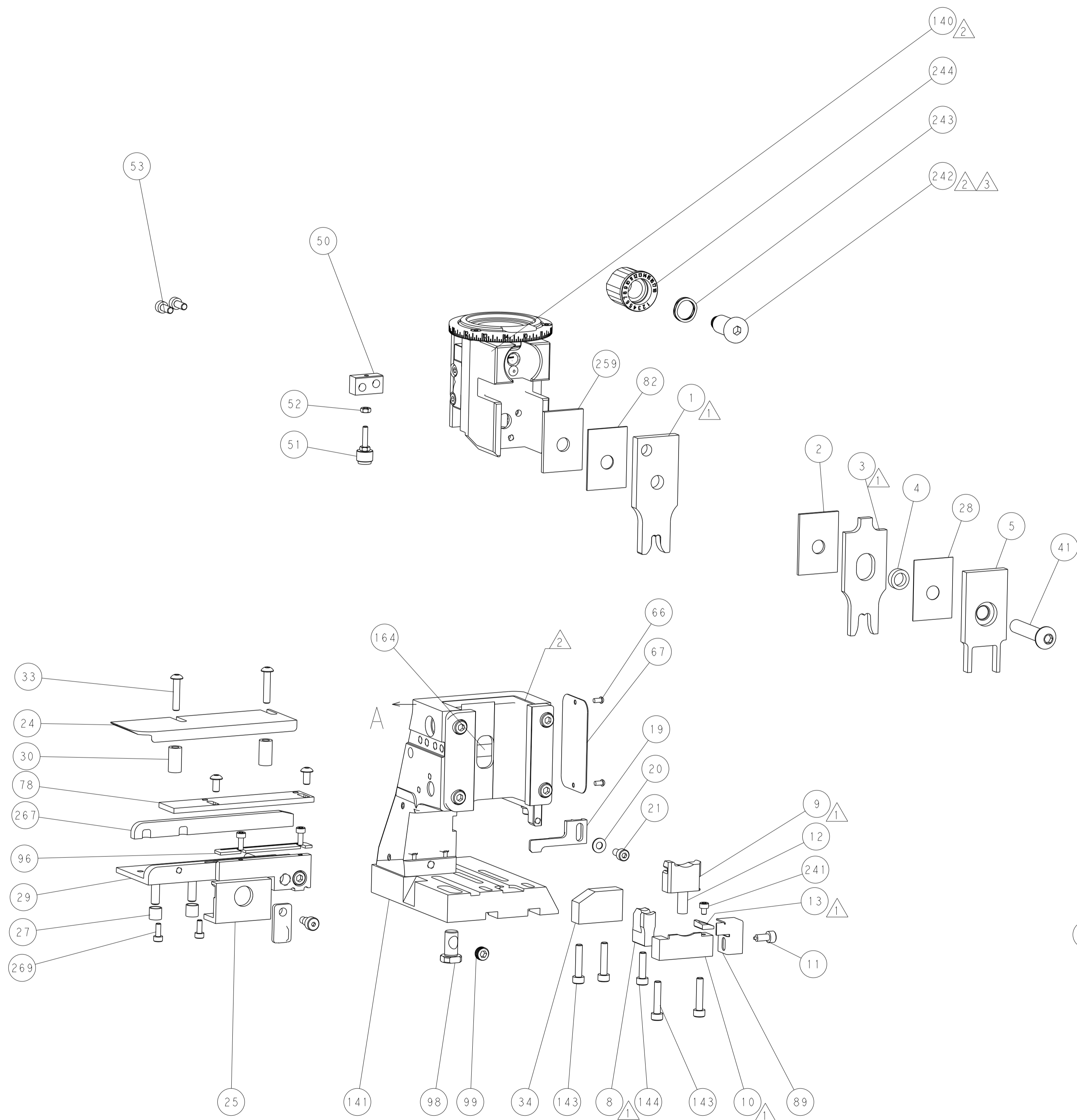

TERMINAL SUPPORT LOCATION

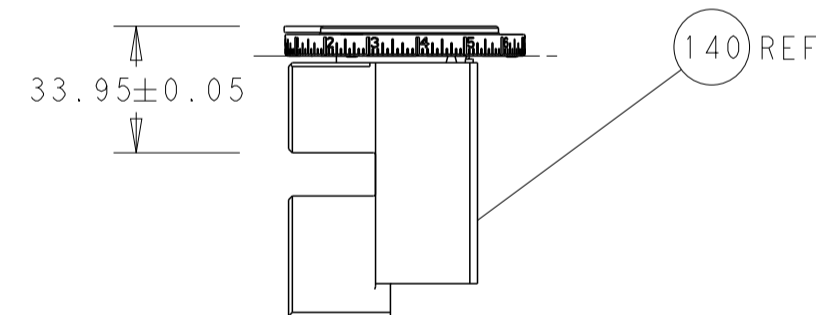

RAM SET-UP

ITEM 30 LOCATED AT REAR HOLES

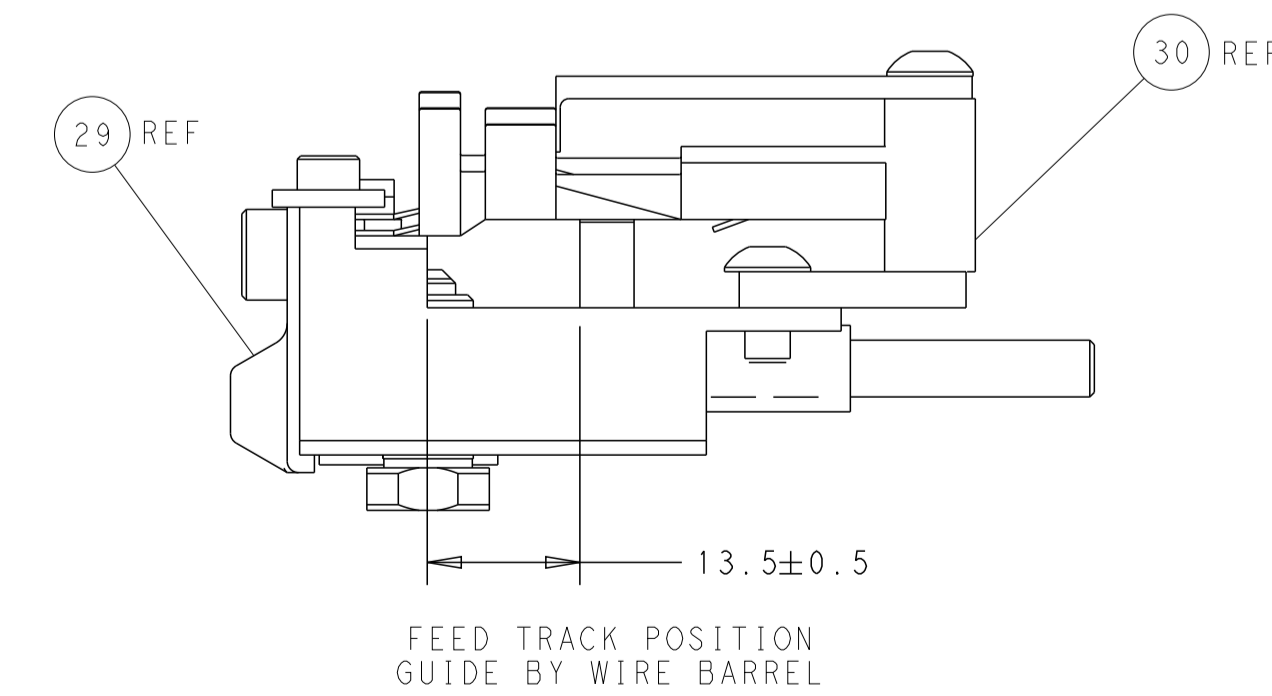

FEED TRACK POSITION GUIDE BY WIRE BARREL

PACIFIC VERSION
 Shown on sheets 3 of 4 & 4 of 4
 (Atlantic version shown on sheets 1 of 4 & 2 of 4)

<small>THIS DRAWING IS UNPUBLISHED. RELEASED FOR PUBLICATION 2014. COPYRIGHT 2014 BY TYCO ELECTRONICS CORPORATION. ALL RIGHTS RESERVED.</small>		DWN: B. WEAVER CHK: T. ELBIN APVD: T. ELBIN	13OCT2014 13OCT2014 13OCT2014	NAME: Ocean Side Feed Applicator SIZE: A1 CAGE CODE: 00779 DRAWING NO: 2266538	RESTRICTED TO: B
DIMENSIONS: mm TOLERANCES UNLESS OTHERWISE SPECIFIED: 0 PLC ± 1 PLC ± 2 PLC ± 3 PLC ± 4 PLC ± ANGLES ± MATERIAL: - FINISH: -	WEIGHT: - SCALE: 1:2 SHEET: 4 OF 4 REV: B	CUSTOMER ACCESSIBLE PRODUCTION DRAWING			