

THIS DRAWING IS UNPUBLISHED.

RELEASED FOR PUBLICATION

© COPYRIGHT

ALL RIGHTS RESERVED.

REVISIONS

P	LTR	DESCRIPTION	DATE	DWN	APVD
	A	NPR ECR-16-008202	07JUN2016	JC	JL
	B	REVISED ECR-18-001208	25JAN2018	JC	LSF

TABLE 2

PLATING	TERMINAL NO	APPLICABLE WIRE RANGE
PRE-TIN	1827483-1	CIVUS/CHFUS 0.13mm ²
GOLD	1827483-2	
PRE-TIN	1674311-7	AVSS/CAVS/CAVUS/AVSSH-f 0.3~0.5mm ²
GOLD	1674311-8	CIVUS/CHFUS/HFSS-f 0.3~0.5mm ²

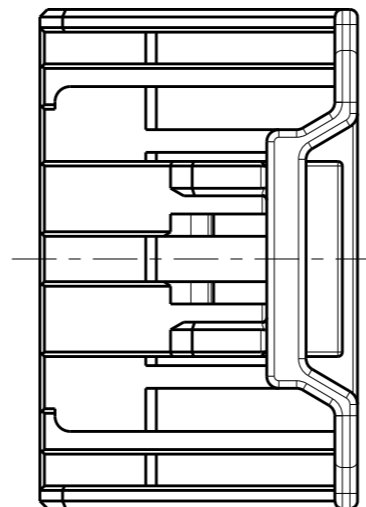
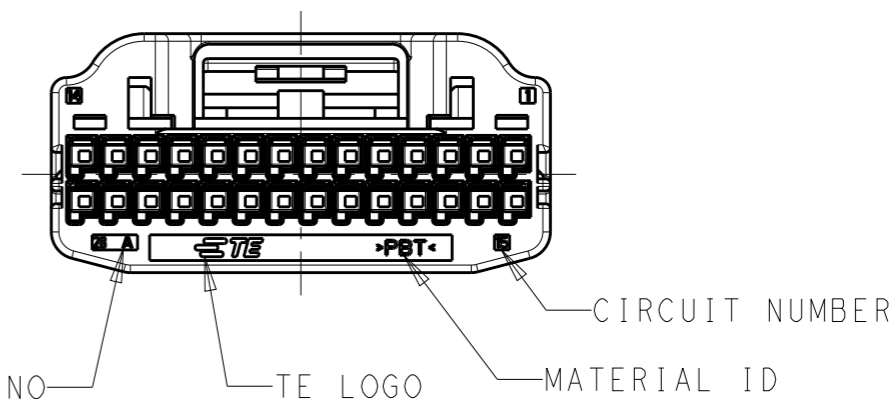
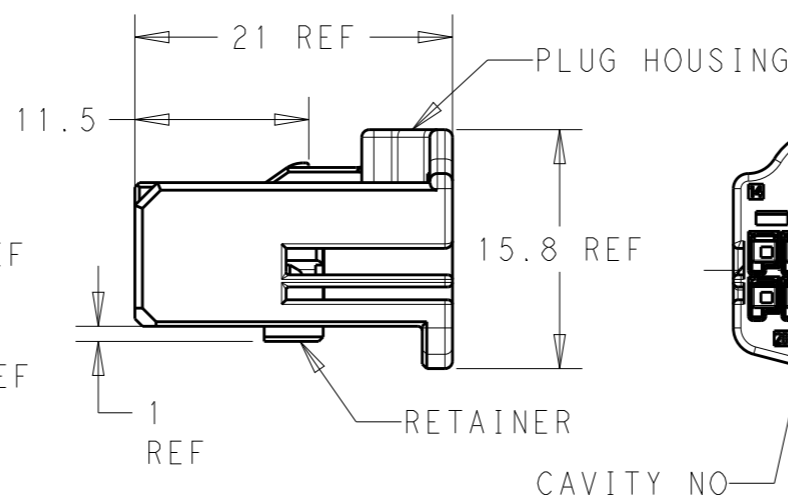
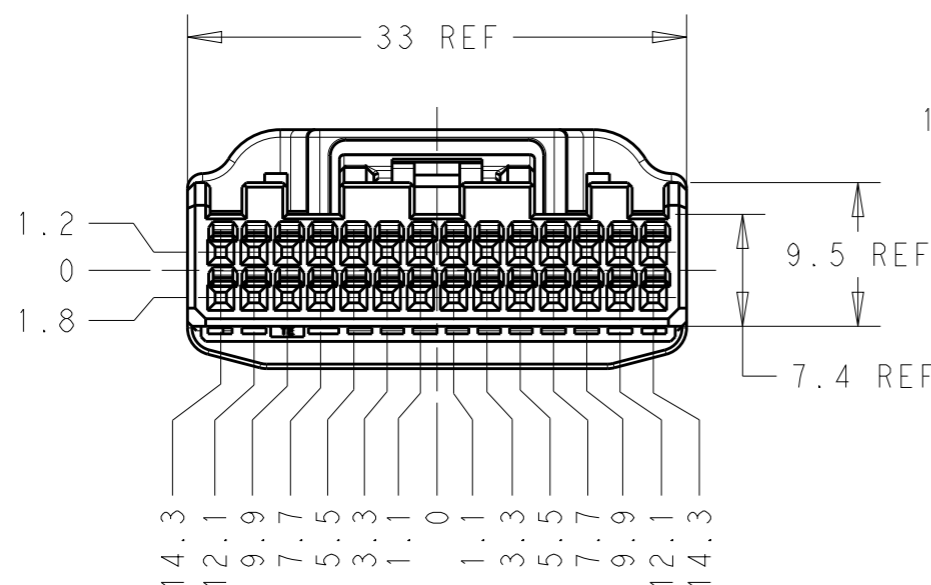

TABLE 1

POS	CAP ASSEMBLY PART NO.	
28	W-W	1565377
	W-B	1565375



NOTES:

1. RETAINER SHOULD BE SET TO THE PRE-ASSEMBLY POSITION WITHIN THE PLUG HOUSING WHEN SHIPPED TO CUSTOMER
2. INSTRUCTION SHEET NO: 411-78080
3. PART NUMBER OF CAP ASSEMBLY TO BE MATED: SEE TABLE 1
4. APPLIED TERMINAL: SEE TABLE 2
5. RETAINER IS THE SAME COLOUR AS HOUSING

BOX	BAG	NATURAL	2237069-1
OUTER	INNER	COLOUR	PART NUMBER
PACKING STYLE			

THIS DRAWING IS A CONTROLLED DOCUMENT.		DWN 07JUN2016 JASON CHOW	STE TE Connectivity
DIMENSIONS: mm		CHK 07JUN2016 JL LIM	
TOLERANCES UNLESS OTHERWISE SPECIFIED:		APVD 07JUN2016 SEIFONG	NAME 28POS, ML .025, REC HSG ASSY WITH ANTI OVER STRESS
0 PLC ±0.3 1 PLC ±0.3 2 PLC ±0.3 3 PLC ±0.3 4 PLC ±0.3 ANGLES ±3°		PRODUCT SPEC 108-5931	SIZE CAGE CODE DRAWING NO RESTRICTED TO
MATERIAL PBT		FINISH SEE TABLE	114-5329
		WEIGHT 4.4g	A300779 C-2237069
		CUSTOMER DRAWING	SCALE 2:1 SHEET 1 OF 1 REV B