

LOC		DIST		REVISIONS			
AD	00	P	LTN	DESCRIPTION	DATE	DWN	APVD
		A1		REVISED PER ECO-15-004792	31MAR2015	AP	DD

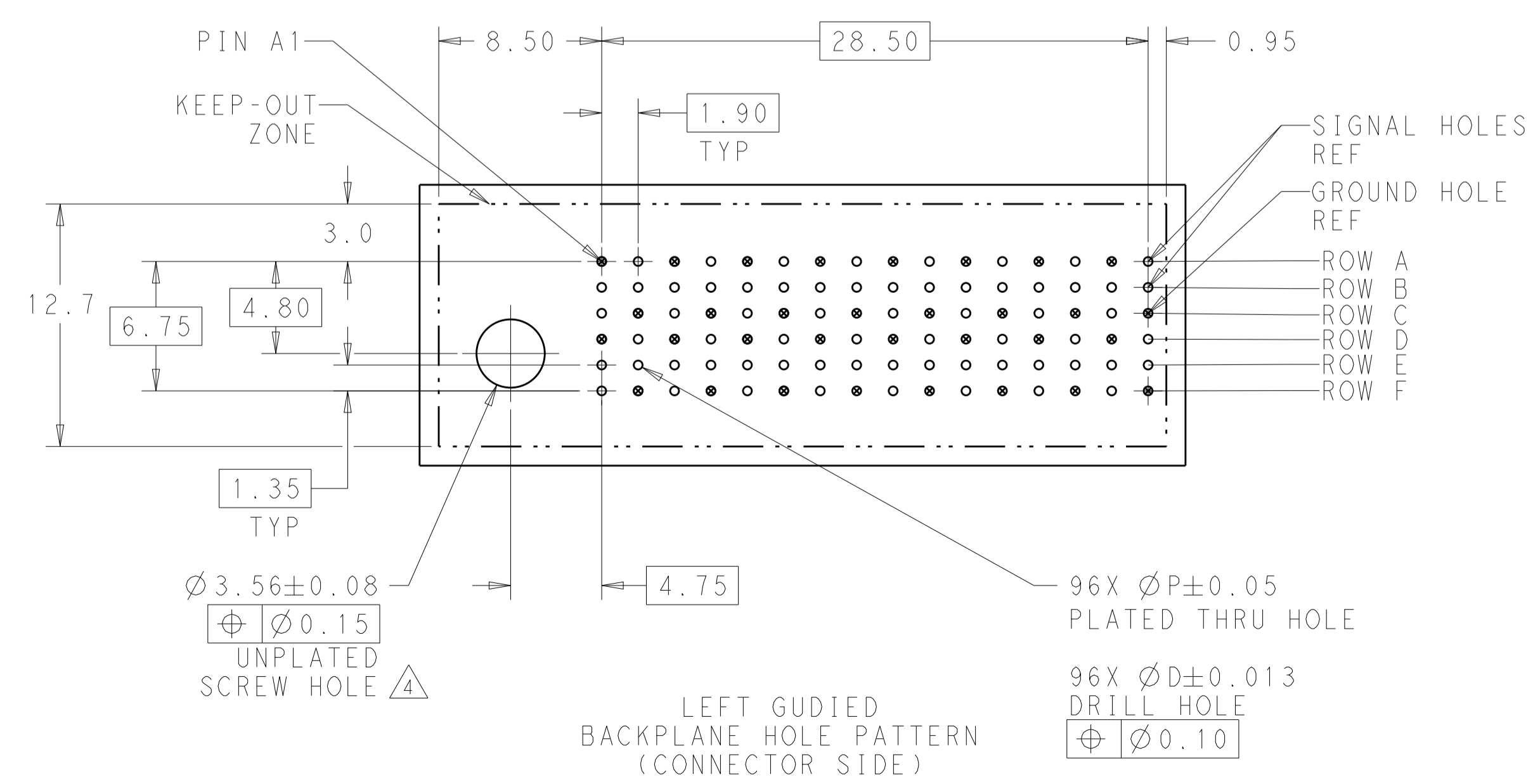
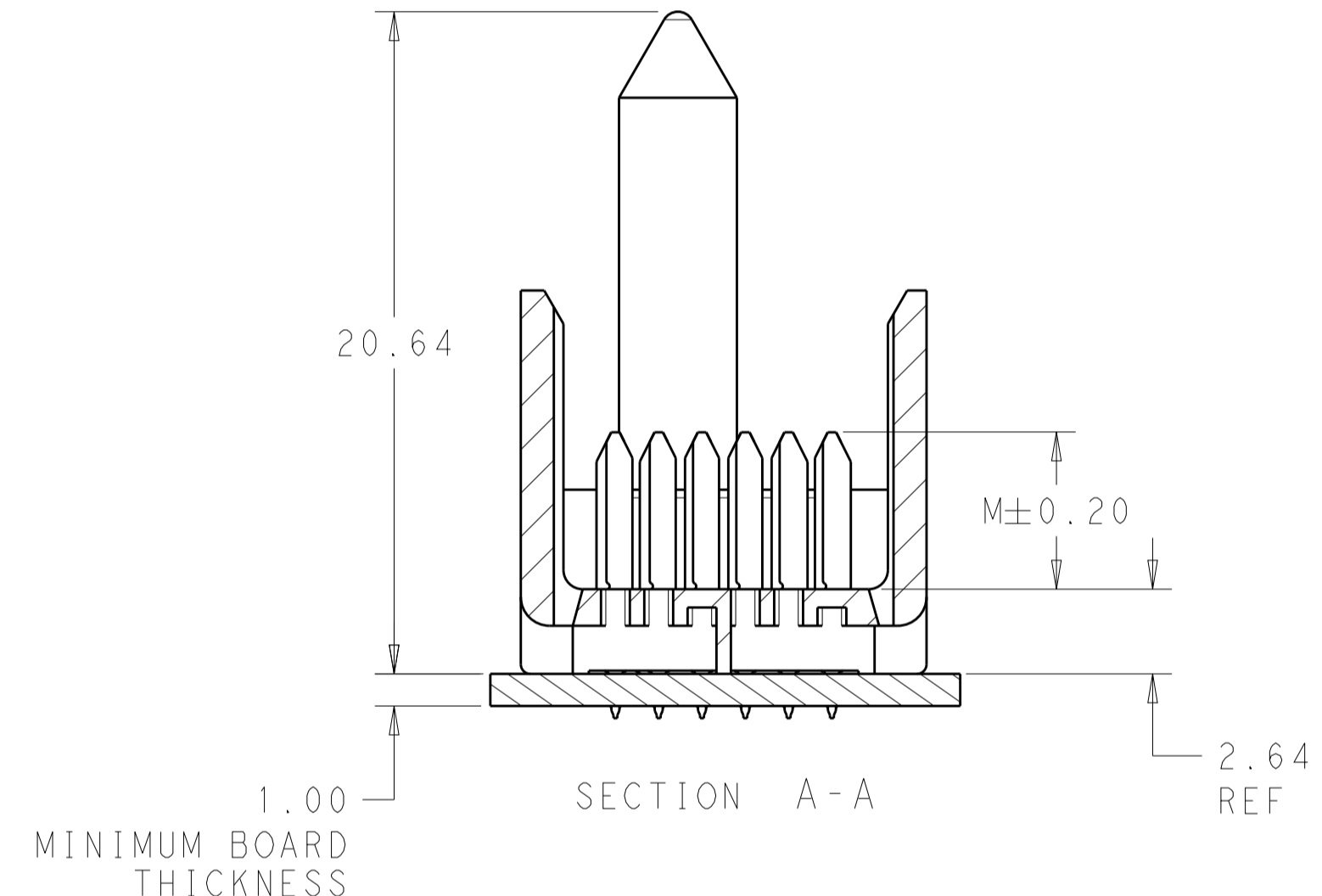
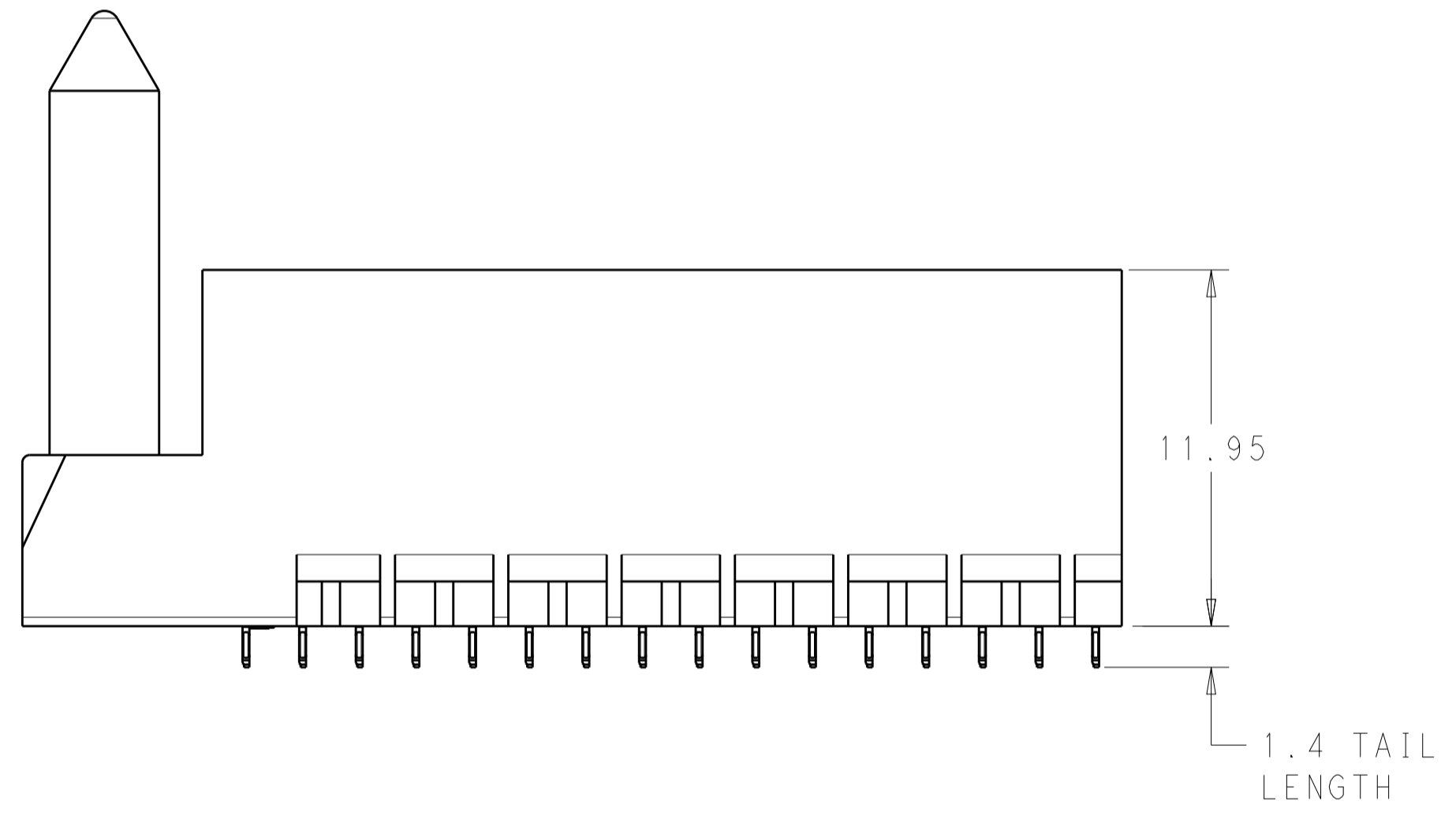
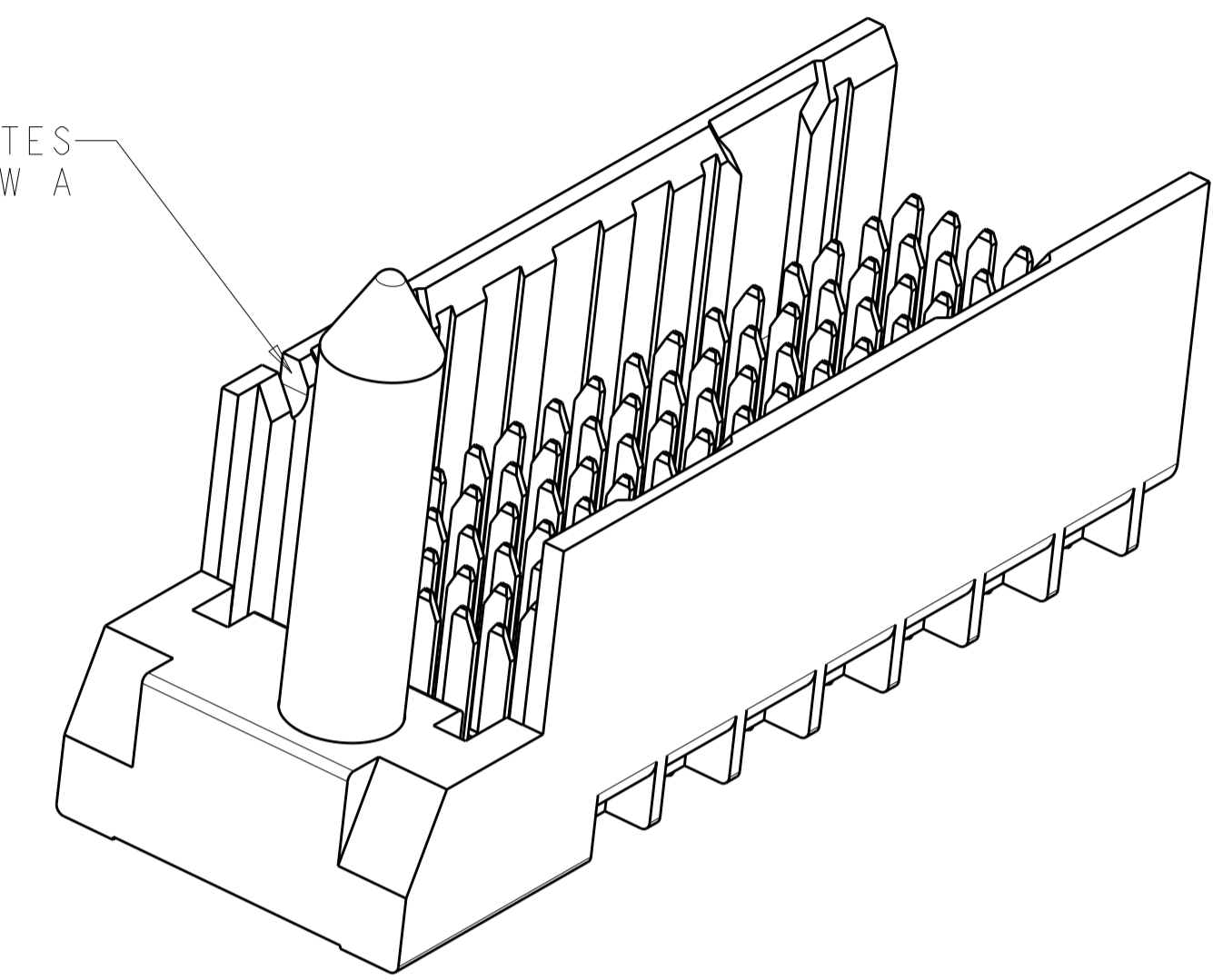
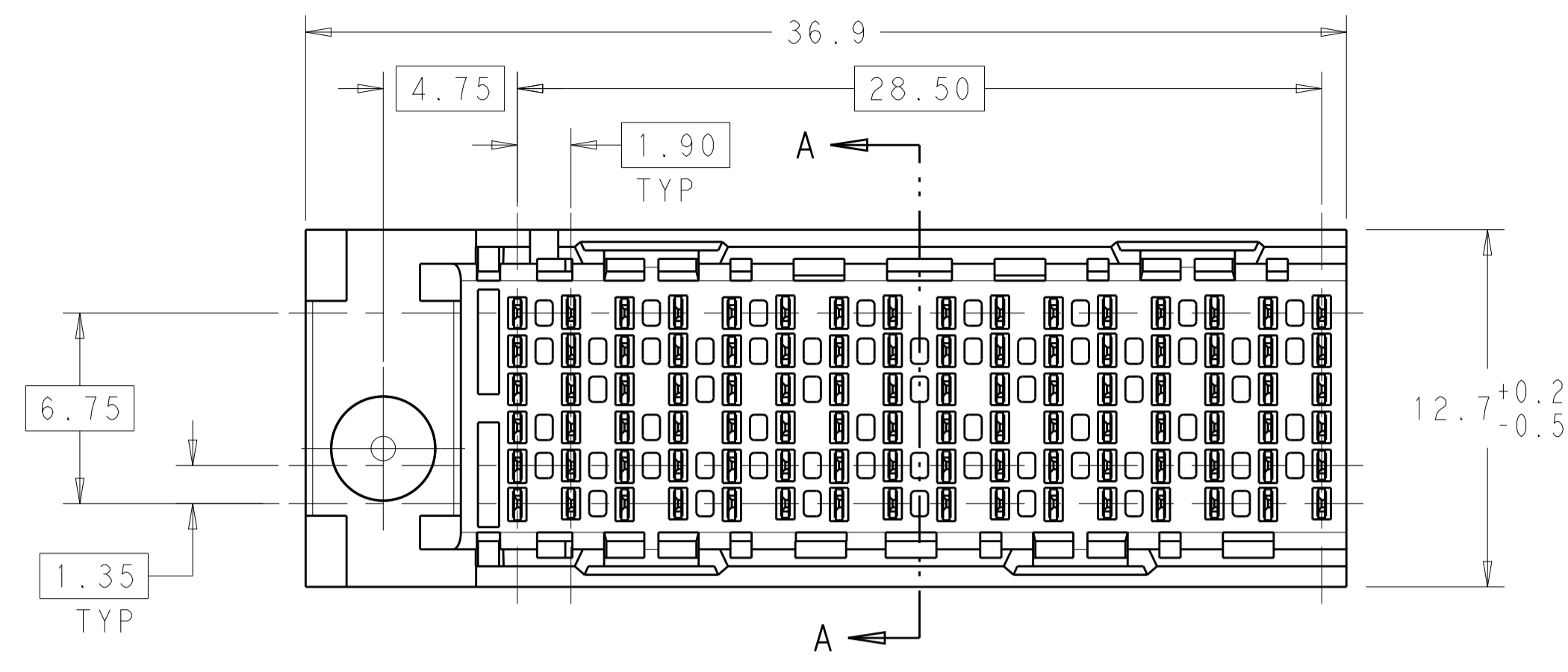

THIS DRAWING IS A CONTROLLED DOCUMENT.		DWN: AJITH PAI 16MAY2014	TE Connectivity
DIMENSIONS: mm		CHK: D. DIXON 16MAY2014	
TOLERANCES UNLESS OTHERWISE SPECIFIED:		APVD: D. DIXON 16MAY2014	NAME: IMPACT.85 OHM, STANDARD 2 PAIR PLUS, 16 COLUMN HEADER, LEFT GUIDED OPEN ENDWALL, SIGNAL MODULE
0 PLC	±	PRODUCT SPEC	APPLICATION SPEC
1 PLC	±0.25	SIZE	CAGE CODE DRAWING NO
2 PLC	±0.13	WEIGHT	RESTRICTED TO
3 PLC	±	A100779C=2227085	
4 PLC	±	CUSTOMER DRAWING	
ANGLES	±	SCALE	5:1
FINISH	SEE TABLE	SHEET	1 OF 2
		REV	A1

THIS DRAWING IS UNPUBLISHED. RELEASED FOR PUBLICATION 20
 © COPYRIGHT 20 BY - ALL RIGHTS RESERVED.

LOC	DIST	REVISIONS					
		P	LTN	DESCRIPTION	DATE	DWN	APVD
AD	00	-	-	SEE SHEET 1	-	-	-

- 1 MATERIAL:
HOUSING: LCP, GLASS FILLED, UL94V-0.
TERMINALS: HIGH PERFORMANCE COPPER ALLOY.
- 2 FINISH:
30μ" MIN GOLD IN CONTACT AREA. SELECTIVE TIN
ON PCB TAILS, NICKEL OVERALL.
- 3. SCREWS PACKAGED IN END OF PACKAGING TUBE.
- 4 FOR GROUNDED GUIDE PIN USE Ø3.56±0.08 PTH,
Ø3.66 DRILL, AND Ø6.5 PAD.
- 5. KEYING PIN SHOWN IN POSITION A, SEE KEYING CHART
ON SHEET 2 FOR OTHER POSITIONS.

0.55	0.46	5.5	2227085-6
0.55	0.46	4.9	2227085-5
0.55	0.46	4.5	2227085-4
0.48	0.39	5.5	2227085-3
0.48	0.39	4.9	2227085-2
0.48	0.39	4.5	2227085-1
D DRILL HOLE SIZE	P PLATED THROUGH HOLE SIZE	M POST LENGTH	PART NUMBER

REFER TO WWW.TE.COM
FOR PRODUCT AVAILABILITY

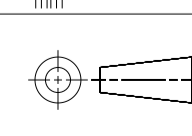
THIS DRAWING IS A CONTROLLED DOCUMENT.		DWN AJITH PAI 16MAY2014	 TE Connectivity
DIMENSIONS: mm		CHK D. DIXON 16MAY2014	
		APVD D. DIXON 16MAY2014	NAME IMPACT.85 OHM, STANDARD, 2 PAIR PLUS, 16 COLUMN HEADER, LEFT GUIDED OPEN ENDWALL, SIGNAL MODULE
TOLERANCES UNLESS OTHERWISE SPECIFIED: 0 PLC ±. 1 PLC ±0.25 2 PLC ±0.13 3 PLC ±. 4 PLC ±. ANGLES ±.		PRODUCT SPEC APPLICATION SPEC	SIZE A1
MATERIAL SEE TABLE		WEIGHT CUSTOMER DRAWING	RESTRICTED TO A100779C=2227085
		SCALE 5:1	SHEET 2 OF 2
			REV A1