

PART NUMBER	REVISION	DESCRIPTION	FEED TYPE
2151803-1	G	FINE CRIMP HEIGHT ADJUST	MECHANICAL
2151803-2	H	FINE CRIMP HEIGHT ADJUST	PNEUMATIC
5-2151803-1	G	SEAL STRIPPER CRIMPER TERMINATING UNIT	MECHANICAL
5-2151803-2	H	SEAL STRIPPER CRIMPER TERMINATING UNIT	PNEUMATIC
7-2151803-1	G	MECHANICAL AND CRIMP TOOLING KIT	MECHANICAL
7-2151803-2	H	PNEUMATIC AND CRIMP TOOLING KIT	PNEUMATIC
7-2151803-7	A	CRIMP TOOLING KIT	-

ATLANTIC VERSION TERMINATOR INTERFACE ADAPTER



APPLICATOR DATA		
CRIMP	SIZE	TYPE
WIRE	1.68 mm [.066]	F
INSUL	2.29 mm [.090]	OV

APPLICATOR INSTRUCTIONS 408-35042

TERMINAL DATA: YAZAKI TERMINAL YAZAKI CRIMP SPECIFICATION			
TERMINAL NAME: 1.5 SYSTEM CONNECTOR FEMALE TERMINAL			
WIRE STRIP LENGTH	INSULATION DIAMETER RANGE		
5.00-5.50 mm [.197-.217 IN]	Ø1.40-2.00 mm [.055-.079 IN]		
TERMINAL APPLICATION SPECIFICATION (A) YPES 72-WT10-1457			
TERMINALS APPLIED			
TE TERMINAL (A) 1572829-1	YAZAKI TERMINAL (A) 7116-4100-02	TE TERMINAL (A) 1572829-2	YAZAKI TERMINAL (A) 7116-4100-08

TERMINAL DATA: YAZAKI TERMINAL YAZAKI CRIMP SPECIFICATION			
TERMINAL NAME: 1.5 SYSTEM CONNECTOR TERMINAL (TAB)			
WIRE STRIP LENGTH	INSULATION DIAMETER RANGE		
5.00-5.50 mm [.197-.217 IN]	Ø1.40-2.20 mm [.055-.087 IN]		
TERMINAL APPLICATION SPECIFICATION (B) YPES 72-WT08-673			
TERMINALS APPLIED			
TE TERMINAL (B) 286669-2	YAZAKI TERMINAL (B) 7114-4100-08	TE TERMINAL	YAZAKI TERMINAL

TERMINAL DATA: YAZAKI TERMINAL YAZAKI CRIMP SPECIFICATION			
TERMINAL NAME: 1.5 SYSTEM-2			
WIRE STRIP LENGTH	INSULATION DIAMETER RANGE		
5.00-5.50 mm [.197-.217 IN]	Ø1.40-1.80 mm [.055-.071 IN]		
TERMINAL APPLICATION SPECIFICATION 12-WT10-3091 Rev			
TERMINALS APPLIED			
TE TERMINAL 1949461-1	YAZAKI TERMINAL 7116-4780-02	TE TERMINAL	YAZAKI TERMINAL

WIRE SIZE	CRIMP HEIGHT mm [INCH]	CRIMP HEIGHT REFERENCE SETTING
0.50mm2	1.00+/-0.05 [.039+/- .002]	8.6
0.35mm2	0.90+/-0.05 [.035+/- .002]	9.6

TERMINAL DATA: YAZAKI TERMINAL YAZAKI CRIMP SPECIFICATION			
TERMINAL NAME: 1.5 SYSTEM CONNECTOR TERMINAL (TAB)			
WIRE STRIP LENGTH	INSULATION DIAMETER RANGE		
5.00-5.50 mm [.197-.217 IN]	Ø1.40-2.20 mm [.055-.087 IN]		
TERMINAL APPLICATION SPECIFICATION (C) YPES 72-WT08-671			
TERMINALS APPLIED			
TE TERMINAL (C) 286669-1	YAZAKI TERMINAL (C) 7114-4100-2	TE TERMINAL	YAZAKI TERMINAL

WIRE SIZE	CRIMP HEIGHT mm [INCH]	CRIMP HEIGHT REFERENCE SETTING
0.50mm2	1.00+/-0.05 [.039+/- .002]	7.2
0.30mm2 or 0.35mm2	0.90+/-0.05 [.035+/- .002]	8.3

WIRE SIZE	CRIMP HEIGHT mm [INCH]	CRIMP HEIGHT REFERENCE SETTING
0.50mm2	1.10+/-0.05 [.043+/- .002]	6.4
0.35mm2	1.00+/-0.05 [.039+/- .002]	7.2

WIRE SIZE	CRIMP HEIGHT mm [INCH]	CRIMP HEIGHT REFERENCE SETTING
2 X 0.35mm2	1.15+/-0.05 [.045+/- .002]	4.8
0.50mm2	1.05+/-0.05 [.041+/- .002]	6.8
0.30mm2 or 0.35mm2	1.00+/-0.05 [.039+/- .002]	7.2

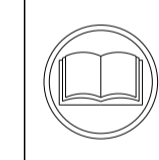

***WARNING**
 ON INSTALLATION, SET WIRE DISC TO CRIMP HEIGHT REFERENCE SETTING FOR LARGEST WIRE SIZE. CRIMP HEIGHT REFERENCE SETTINGS GREATER THAN THE VALUE SHOWN MAY CAUSE DAMAGE TO THE CRIMP TOOLING. REFER TO THE INSTRUCTION SHEET FOR PROPER SETUP AND ADJUSTMENTS.

- 1 RECOMMENDED SPARE PARTS
- 2 REFER TO SUPPLIED INSTRUCTION SHEET FOR CLEANING, LUBRICATION AND STORAGE OF APPLICATOR.
- 3 APPLY PART NUMBER 2-23419-6 LOCTITE TO THREADS OF ITEM 242. APPLY PART NUMBER 1-23419-5 LOCTITE TO THREADS OF ITEM 180.
- 4 CRIMP HEIGHT REFERENCE SETTING WAS THE SETTING USED WHEN THE APPLICATOR WAS QUALIFIED AT THE FACTORY. ADJUSTMENT MAY BE NECESSARY WHEN RUNNING APPLICATOR IN THE FIELD.
- 5 TERMINAL LUBRICANT IS RECOMMENDED.
- 6. UNLESS SPECIFIED OTHERWISE TORQUE VALUES SHALL BE USED PER DOCUMENT, 101-35000.
- 7 WIRE COMBINATION IS NOT LISTED ON YAZAKI SPECIFICATION.

LOC	DIST	REVISIONS					
A	66	P	LTN	DESCRIPTION	DATE	OWN	APVD
		G		ECR-18-015854	06OCT2018	TB	TE
		G1		ECR-19-002576	19FEB2019	FJ	YY
		H		ECR-19-009013	09JUN2019	TB	TE
		H1		ECR-23-164186	19JAN2023	TB	GB

-	-	-	1	1	-	-	1803515-3	RAM ASSEMBLY, SF ATLANTIC	293
-	-	-	1	1	-	-	2-1803583-1	APPLICATOR BASIC ASSEMBLY, SF	292
-	1	-	1	-	1	-	2119641-1	FEED CAM, AIR FEED	248
-	1	1	1	1	1	1	2119082-5	CAM, SNAIL, INSULATION ADJUSTMENT	244
-	1	1	1	1	1	1	2079764-1	WASHER, WAVE SPRING, CREST-TO-CREST	243
-	1	1	1	1	1	1	2119083-1	RETAINER, INSULATION DIAL	242
-	1	1	1	1	1	1	7-18023-7	SCR, SKT HD CAP M3 X 4.0	241
-	-	1	-	1	-	1	2119580-1	MECHANICAL FEED ASSEMBLY	239
-	1	-	1	-	1	-	2844940-1	AIR FEED MODULE	238
-	-	-	1	1	-	-	4-1722335-3	STRIPPER, SIDE FEED	182
-	-	-	1	1	-	-	1-5018030-0	NUT, HEX, REG, RoHS, M3.5	181
-	-	-	1	1	-	-	1-1752354-5	STANDOFF, HOLD-DOWN	180
-	-	-	1	1	-	-	9931111-1	PIN, SLOTTED SPRING 3.0 X 20.0	177
-	-	-	1	1	-	-	5-22280-0	SPRING, COMPRESSION	176
-	-	-	1	1	-	-	1752353-3	GUIDE PIN, HOLDDOWN	175
-	-	-	1	1	-	-	1901680-2	GUIDE PIN, HOLDDOWN	174
-	REF	REF	REF	REF	REF	REF	994970-2	COUNTER, MAGNETIC	164
-	1	1	1	1	1	1	1-22281-8	SPRING, COMPRESSION	121
-	1	1	1	1	1	1	2119955-1	ASSY, LUBRICATOR, SIDE FEED	113
-	1	1	1	1	1	1	2844908-1	SCREW, LOCKING	99
-	1	1	1	1	1	1	2844907-1	POST, LOCKING	98
-	1	1	1	1	1	1	1-690438-0	FRONT STRIP GUIDE	96
-	2	2	2	2	2	2	2168083-1	SCR, SKT HD CAP, RoHS, M3 X 8.0	95
-	1	1	1	1	1	1	2168083-6	SCR, SKT HD CAP, RoHS, M5 X 65	93
-	1	1	1	1	1	1	455888-5	SPACER, CRIMPER	82
-	1	1	1	1	1	1	1803607-3	DOCUMENTATION PACKAGE	71
-	1	1	1	1	1	1	2119791-5	DEPRESSOR, WIRE	70
-	1	1	1	1	1	1	2119943-1	WASHER, SPACER	69
-	1	1	1	1	1	1	2119740-1	TAG, IDENTIFICATION	67
-	2	2	2	2	2	2	2168078-1	SCREW, DRIVE, RH, RoHS, 2 x .188	66
-	2	2	2	2	2	2	2-18032-5	SCR, SET, FLT PNT, M5 X 20.0	61
-	1	1	1	1	1	1	2168083-2	SCR, SKT HD CAP, RoHS, M4 X 8.0	60
-	1	1	1	1	1	1	5-18022-5	SCR, HEX HD CAP, M4 X 6.0	59
-	1	1	1	1	1	1	1338685-1	PAWL, FEED	56
-	4	4	4	4	4	4	2168083-3	SCR, SKT HD CAP, RoHS, M4 X 12.0	54
-	2	2	2	2	2	2	2168083-3	SCR, SKT HD CAP, RoHS, M4 X 12.0	53
-	1	1	1	1	1	1	1803382-6	HOLD DOWN, SPRING LOADED	50
-	1	2	1	2	1	2	18023-9	SCR, SKT HD CAP M4 X 6.0	49
-	-	1	-	1	-	1	2119652-1	FEED CAM, PRE FEED	48
-	-	1	-	1	-	1	2119653-1	FEED CAM, POST FEED	47
-	1	1	-	-	1	1	1803583-9	APPLICATOR BASIC ASSEMBLY, SF	46
-	1	1	-	-	1	1	1803515-1	RAM ASSEMBLY, SF ATLANTIC	44
-	1	1	1	1	1	1	1803602-1	SCR, BHSC, RoHS (M8 X 25)	41
-	1	1	1	1	1	1	1752356-3	SUPPORT, TERMINAL	34
-	2	2	2	2	2	2	2079383-5	SCR, BHSC, RoHS (M4 X 20)	33
-	2	2	2	2	2	2	2-2844962-8	SPACER, CYLINDRICAL, STRIP GUIDE	30
-	1	1	1	1	1	1	2844938-6	PLATE, STRIP GUIDE	29
-	1	1	1	1	1	1	455888-3	SPACER, CRIMPER	28
-	2	2	2	2	2	2	22283-1	SPRING, COMPRESSION	27
-	1	1	1	1	1	1	356835-1	LEVER, DRAG RELEASE	26
-	1	1	1	1	1	1	240792-1	DRAG, TERMINAL	25
-	1	1	1	1	1	1	1320928-6	STRIP GUIDE	24
-	1	1	1	1	1	1	980371-4	SCR, SKT HD SHLDR 5.0 DIA X 6.0	23
-	1	1	-	-	1	1	2168083-2	SCR, SKT HD CAP, RoHS, M4 X 8.0	21
-	2	2	1	1	2	2	1-18028-2	WASHER, FLAT, REG M4	20
-	1	1	-	-	1	1	2119533-1	STRIPPER, SIDE FEED	19
-	1	1	1	1	1	1	2119806-1	INSERT, SHEAR	13
-	1	1	1	1	1	1	3-22280-3	SPRING, COMPRESSION	12
-	1	1	1	1	1	1	1-356885-3	STOP, SHEAR	11
-	1	1	1	1	1	1	2119805-1	SHEAR HOLDER, FRONT	10
-	1	1	1	1	1	1	1803095-5	FLOATING SHEAR, FRONT	9
-	1	2	2	1	1	1	2-1333225-1	ANVIL, COMBINATION	8
-	1	1	1	1	1	1	4-240641-2	SPACER	7
-	-	-	-	-	-	-	-	-	6
-	1	1	1	1	1	1	2119757-8	DEPRESSOR, SHEAR	5
-	1	1	1	1	1	1	238011-4	BLOCK, CRIMPER SPACER	4
-	1	2	2	1	1	1	2-1633964-7	CRIMPER, INSULATION OVERLAP PREMIUM	3
-	1	1	1	1	1	1	455888-3	SPACER, CRIMPER	2
-	1	2	2	1	1	1	1-1803556-1	CRIMPER, WIRE F	1

ATLANTIC VERSION
 Shown on sheets 1 of 4 & 2 of 4
 (Pacific version shown on sheets 3 of 4 & 4 of 4)

DIMENSIONS:		TOLERANCES UNLESS OTHERWISE SPECIFIED:		MATERIAL:		FINISH:	
mm	0 PLC ±.05	1 PLC ±.05	2 PLC ±.05	3 PLC ±.05	4 PLC ±.05	ANGLES ±.0001	

CHK	H. HUANG	08NOV2012	OWN	H. HUANG	08NOV2012
APVD	S. XI	08NOV2012	NAME	Ocean Side Feed Applicator	
PRODUCT SPEC					
APPLICATION SPEC					
SIZE	CAGE CODE	DRAWING NO	RESTRICTED TO		
A1	00779	2151803			
Customer Accessible Production Drawing			SCALE	1:2	SHEET 1 of 4

LOC	DIST	REVISIONS					
A	66	P	LTN	DESCRIPTION	DATE	DWN	APVD
		-		SEE SHEET 1			

FEED TYPE MECHANICAL

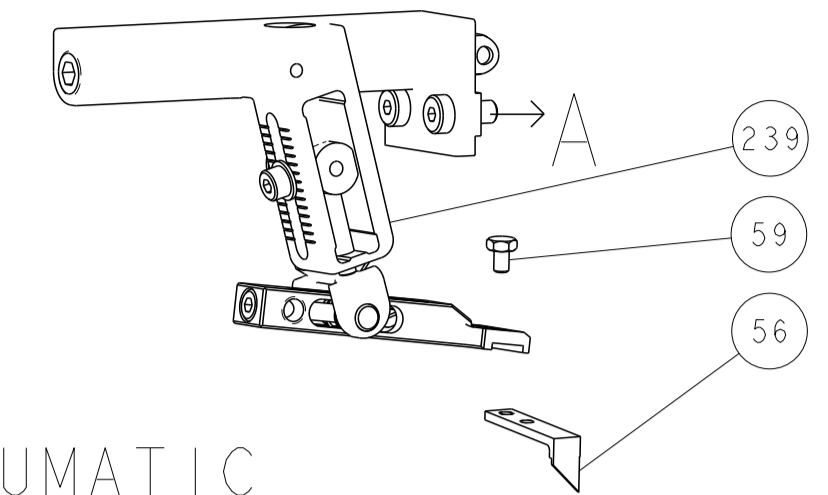

PNEUMATIC

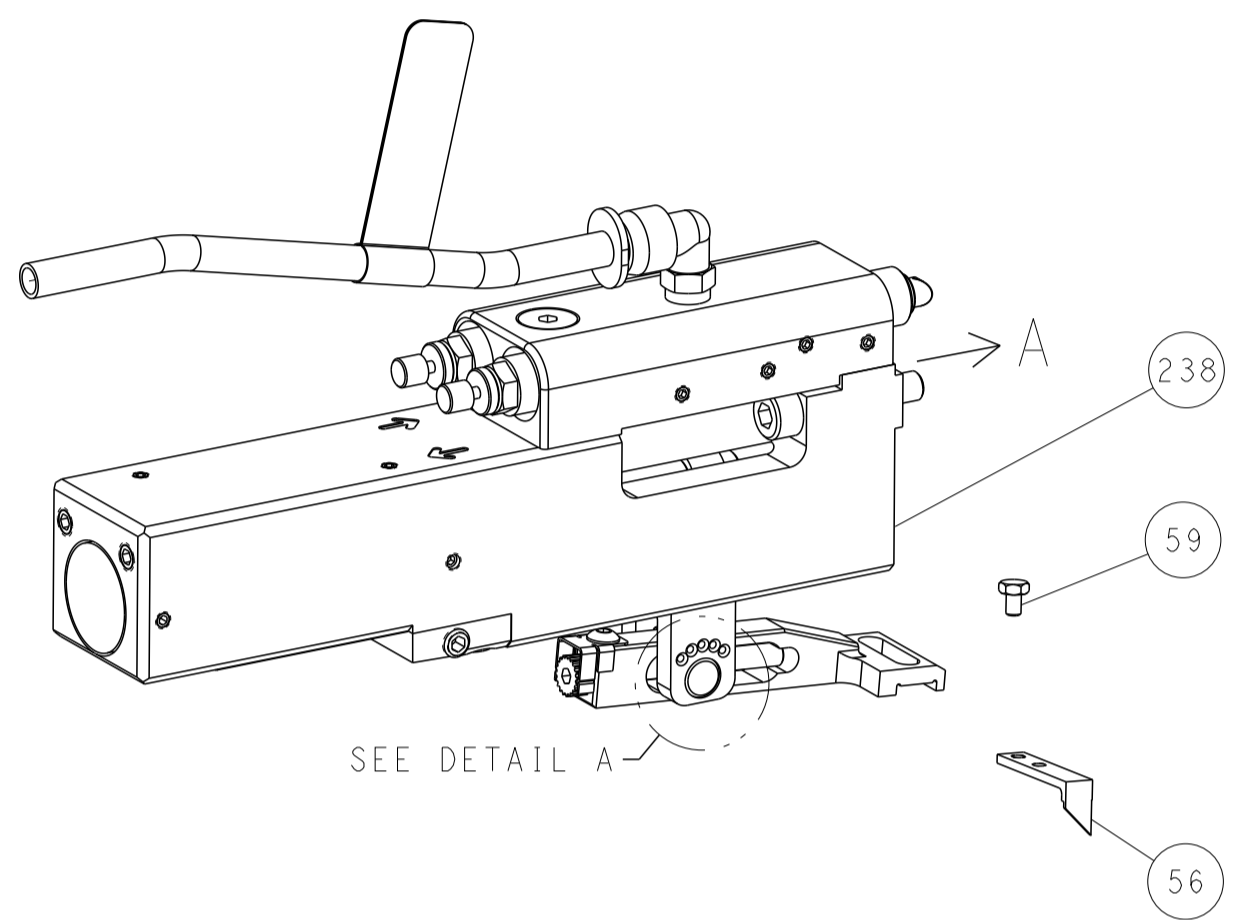

FEED SPRING SETTING POSITION (SHOWN FROM REAR SIDE)



DETAIL A

CAM POSITIONS

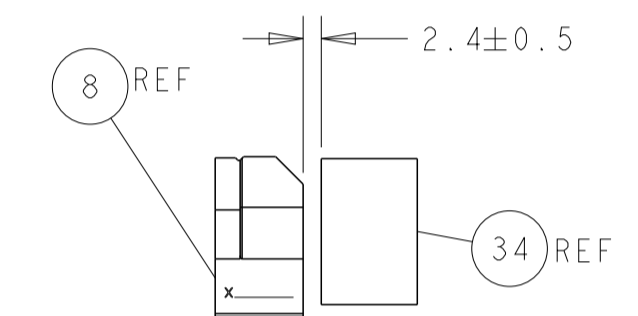
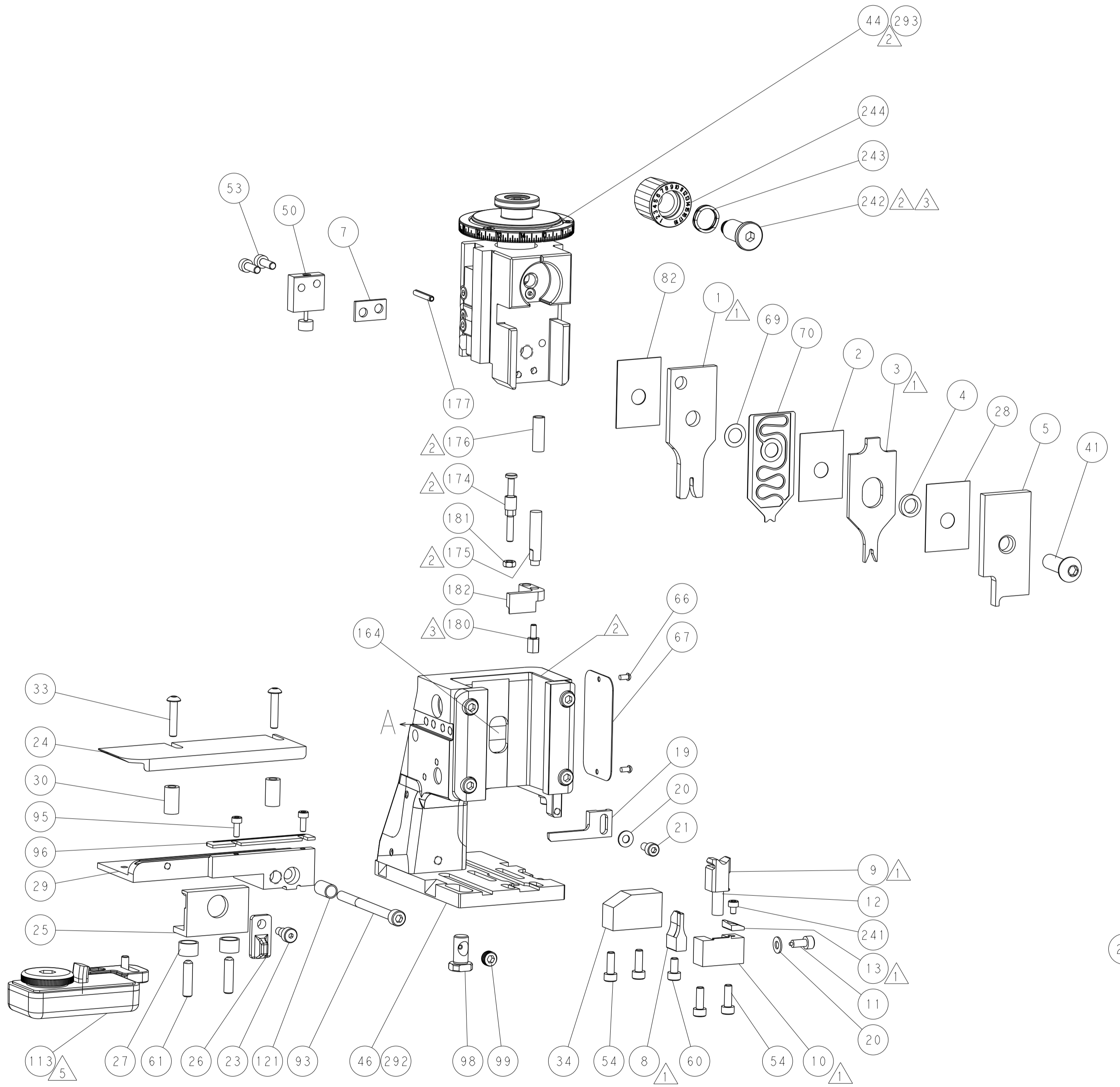
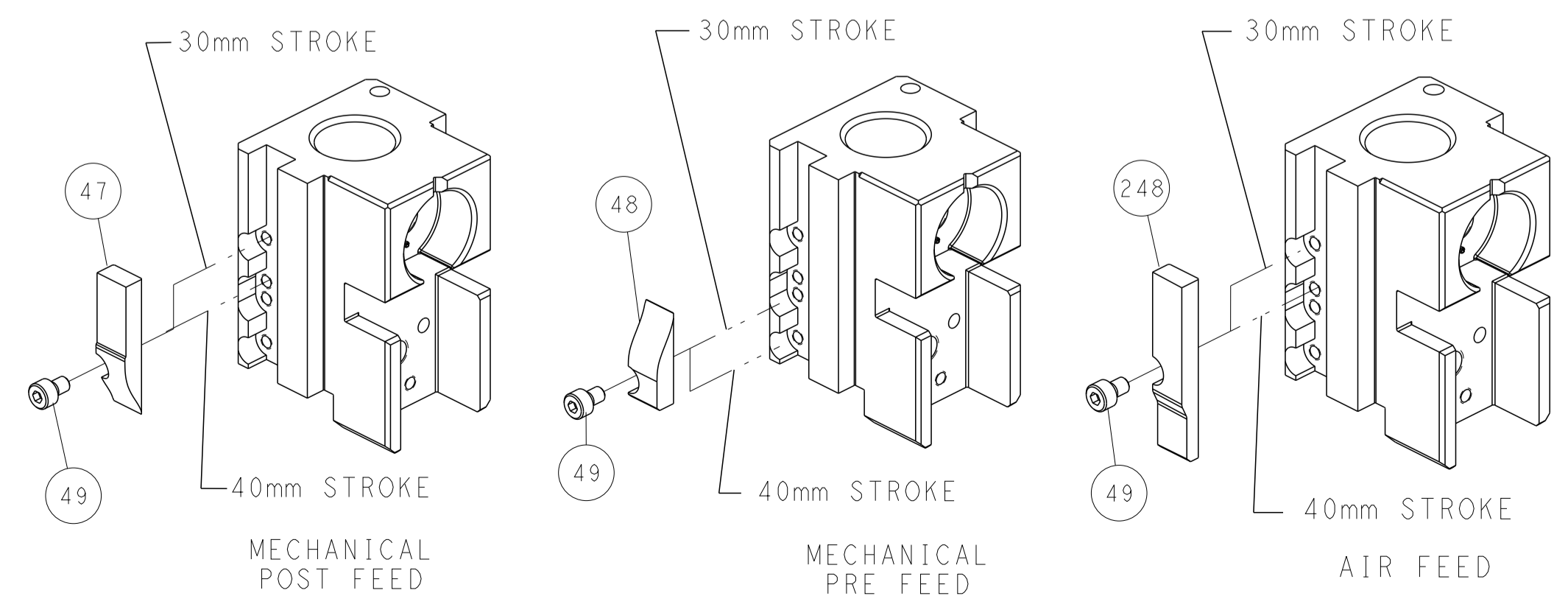

TERMINAL SUPPORT LOCATION

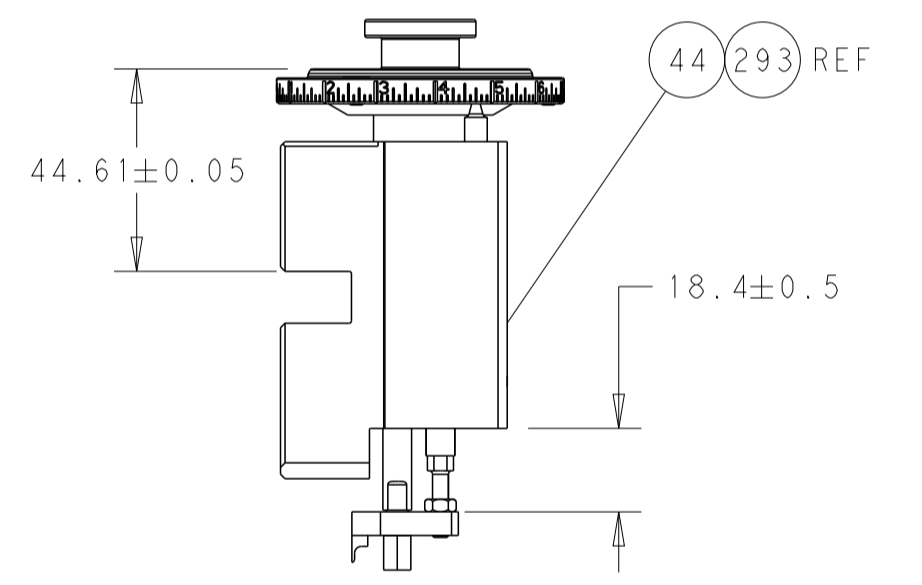

RAM AND HOLDDOWN SET-UP

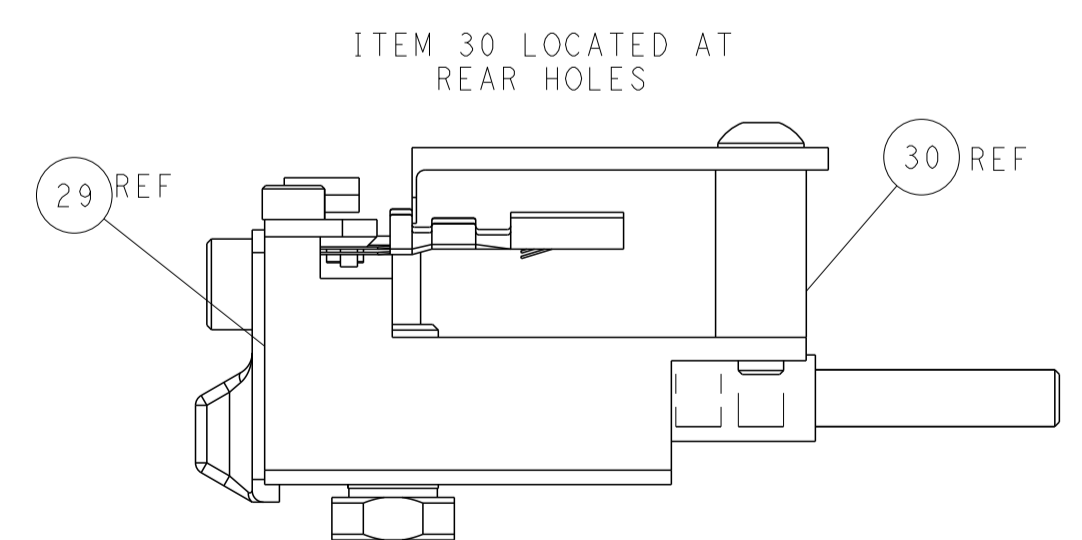

FEED TRACK POSITION GUIDE BY INSULATION BARREL

ATLANTIC VERSION
 Shown on sheets 1 of 4 & 2 of 4
 (Pacific version shown on sheets 3 of 4 & 4 of 4)

<small>THIS DRAWING IS UNPUBLISHED. RELEASED FOR PUBLICATION BY TYCO ELECTRONICS CORPORATION. ALL RIGHTS RESERVED.</small>		DWN: R. HUANG 08NOV2012 CHK: S. XI 08NOV2012 APVD: S. XI 08NOV2012	TE Connectivity Harrisburg, PA 17105-3608
DIMENSIONS: mm TOLERANCES UNLESS OTHERWISE SPECIFIED: 0 PLC ±0.5 1 PLC ±0.13 3 PLC ±0.013 4 PLC ±0.001 ANGLES FINISH		NAME: Ocean Side Feed Applicator PRODUCT SPEC: APPLICATION SPEC: WEIGHT: SCALE: 1:2	SIZE: A1 CAGE CODE: 00779 DRAWING NO: 2151803 SHEET 2 OF 4 REV: H1
MATERIAL:		RESTRICTED TO:	

PART NUMBER	REVISION	DESCRIPTION	FEED TYPE
2-2151803-1	G	FINE CRIMP HEIGHT ADJUST	MECHANICAL
2-2151803-2	H	FINE CRIMP HEIGHT ADJUST	PNEUMATIC
7-2151803-7	A	CRIMP TOOLING KIT	-

PACIFIC VERSION TERMINATOR
INTERFACE ADAPTER



APPLICATOR DATA		
CRIMP	SIZE	TYPE
WIRE	1.68 mm [0.066]	F
INSUL	2.29 mm [0.090]	OV
APPLICATOR INSTRUCTIONS 408-35042		

TERMINAL DATA: YAZAKI TERMINAL		YAZAKI CRIMP SPECIFICATION	
TERMINAL NAME: 1.5 SYSTEM-2			
WIRE STRIP LENGTH	5.00-5.50 mm [0.197-.217 IN]	INSULATION DIAMETER RANGE	Ø1.40-1.80 mm [0.055-.071 IN]
TERMINAL APPLICATION SPECIFICATION	12-WT10-3091 Rev		
TERMINALS APPLIED			
TE TERMINAL	YAZAKI TERMINAL	TE TERMINAL	YAZAKI TERMINAL
1949461-1	7116-4780-02		

WIRE SIZE	CRIMP HEIGHT mm [INCH]	CRIMP HEIGHT REFERENCE SETTING
0.50mm2	1.00+/-0.05 [0.039+/-0.002]	8.6
0.35mm2	0.90+/-0.05 [0.035+/-0.002]	9.6

TERMINAL DATA: YAZAKI TERMINAL		YAZAKI CRIMP SPECIFICATION	
TERMINAL NAME: 1.5 SYSTEM CONNECTOR FEMALE TERMINAL			
WIRE STRIP LENGTH	5.00-5.50 mm [0.197-.217 IN]	INSULATION DIAMETER RANGE	Ø1.40-2.00 mm [0.055-.079 IN]
TERMINAL APPLICATION SPECIFICATION	(A)YPES 72-WT10-1457		
TERMINALS APPLIED			
TE TERMINAL	YAZAKI TERMINAL	TE TERMINAL	YAZAKI TERMINAL
(A) 1572829-1	(A) 7116-4100-02	(A) 1572829-2	(A) 7116-4100-08

TERMINAL DATA: YAZAKI TERMINAL		YAZAKI CRIMP SPECIFICATION	
TERMINAL NAME: 1.5 SYSTEM CONNECTOR TERMINAL (TAB)			
WIRE STRIP LENGTH	5.00-5.50 mm [0.197-.217 IN]	INSULATION DIAMETER RANGE	Ø1.40-2.20 mm [0.055-.087 IN]
TERMINAL APPLICATION SPECIFICATION	(B)YPES 72-WT08-673		
TERMINALS APPLIED			
TE TERMINAL	YAZAKI TERMINAL	TE TERMINAL	YAZAKI TERMINAL
(B) 286669-2	(B) 7114-4100-08		

TERMINAL DATA: YAZAKI TERMINAL		YAZAKI CRIMP SPECIFICATION	
TERMINAL NAME: 1.5 SYSTEM CONNECTOR TERMINAL (TAB)			
WIRE STRIP LENGTH	5.00-5.50 mm [0.197-.217 IN]	INSULATION DIAMETER RANGE	Ø1.40-2.20 mm [0.055-.087 IN]
TERMINAL APPLICATION SPECIFICATION	(C)YPES 72-WT08-671		
TERMINALS APPLIED			
TE TERMINAL	YAZAKI TERMINAL	TE TERMINAL	YAZAKI TERMINAL
(C) 286669-1	(C) 7114-4100-2		

WIRE SIZE	CRIMP HEIGHT mm [INCH]	CRIMP HEIGHT REFERENCE SETTING
0.50mm2	1.00+/-0.05 [0.039+/-0.002]	7.2
0.30mm2 or 0.35mm2	0.90+/-0.05 [0.035+/-0.002]	8.3

WIRE SIZE	CRIMP HEIGHT mm [INCH]	CRIMP HEIGHT REFERENCE SETTING
0.50mm2	1.10+/-0.05 [0.043+/-0.002]	6.4
0.35mm2	1.00+/-0.05 [0.039+/-0.002]	7.2

WIRE SIZE	CRIMP HEIGHT mm [INCH]	CRIMP HEIGHT REFERENCE SETTING
2 X 0.35mm2	1.15+/-0.05 [0.045+/-0.002]	4.8
0.50mm2	1.05+/-0.05 [0.041+/-0.002]	6.8
0.30mm2 or 0.35mm2	1.00+/-0.05 [0.039+/-0.002]	7.2

***WARNING**
ON INSTALLATION, SET WIRE DISC TO CRIMP HEIGHT REFERENCE SETTING FOR LARGEST WIRE SIZE. CRIMP HEIGHT REFERENCE SETTINGS GREATER THAN THE VALUE SHOWN MAY CAUSE DAMAGE TO THE CRIMP TOOLING. REFER TO THE INSTRUCTION SHEET FOR PROPER SETUP AND ADJUSTMENTS.

- RECOMMENDED SPARE PARTS
- REFER TO SUPPLIED INSTRUCTION SHEET FOR CLEANING, LUBRICATION AND STORAGE OF APPLICATOR.
- APPLY PART NUMBER 2-23419-6 LOCTITE TO THREADS OF ITEM 242.
- CRIMP HEIGHT REFERENCE SETTING WAS THE SETTING USED WHEN THE APPLICATOR WAS QUALIFIED AT THE FACTORY. ADJUSTMENT MAY BE NECESSARY WHEN RUNNING APPLICATOR IN THE FIELD.
- TERMINAL LUBRICANT IS RECOMMENDED.
- UNLESS SPECIFIED OTHERWISE TORQUE VALUES SHALL BE USED PER DOCUMENT, 101-35000.
- WIRE COMBINATION IS NOT LISTED ON YAZAKI SPECIFICATION.

LOC		DIST		REVISIONS			
A	66	P	LTN	DESCRIPTION	DATE	OWN	APVD
-	-	-	-	SEE SHEET 1	-	-	-
-	1	1	2119082-5	CAM, SNAIL, INSULATION ADJUSTMENT			244
-	1	1	2079764-1	WASHER, WAVE SPRING, CREST-TO-CREST			243
-	1	1	2119083-1	RETAINER, INSULATION DIAL			242
-	1	1	7-18023-7	SCR, SKT HD CAP M3 X 4.0			241
-	-	1	2119580-1	MECHANICAL FEED ASSEMBLY			239
-	1	-	2844940-1	AIR FEED MODULE			238
-	REF	REF	994970-2	COUNTER, MAGNETIC			164
-	1	-	2119641-2	FEED CAM, AIR FEED			151
-	1	1	2168083-8	SCR, SKT HD CAP, RoHS, M4 X 16			144
-	4	4	2168083-9	SCR, SKT HD CAP, RoHS, M4 X 20			143
-	-	1	2119653-2	FEED CAM, POST FEED			142
-	1	1	1-1803583-0	APPLICATOR BASIC ASSEMBLY, SF			141
-	1	1	1803516-1	RAM ASSEMBLY, SF PACIFIC			140
-	1	1	1-22281-8	SPRING, COMPRESSION			121
-	1	1	2119955-1	ASSY, LUBRICATOR, SIDE FEED			113
-	1	1	2844908-1	SCREW, LOCKING			99
-	1	1	2844907-1	POST, LOCKING			98
-	1	1	1-690438-0	FRONT STRIP GUIDE			96
-	2	2	2168083-1	SCR, SKT HD CAP, RoHS, M3 X 8.0			95
-	1	1	2168083-6	SCR, SKT HD CAP, RoHS, M5 X 65			93
-	1	1	455888-5	SPACER, CRIMPER			82
-	1	1	1803607-3	DOCUMENTATION PACKAGE			71
-	1	1	2119791-5	DEPRESSOR, WIRE			70
-	1	1	2119943-1	WASHER, SPACER			69
-	1	1	2119740-1	TAG, IDENTIFICATION			67
-	2	2	2168078-1	SCREW, DRIVE, RH, RoHS, 2 x .188			66
-	2	2	2-18032-5	SCR, SET, FLT PNT, M5 X 20.0			61
-	1	1	5-18022-5	SCR, HEX HD CAP, M4 X 6.0			59
-	1	1	1338685-1	PAWL, FEED			56
-	2	2	2168083-3	SCR, SKT HD CAP, RoHS, M4 X 12.0			53
-	1	1	1803382-6	HOLD DOWN, SPRING LOADED			50
-	1	2	18023-9	SCR, SKT HD CAP M4 X 6.0			49
-	-	1	2119652-1	FEED CAM, PRE FEED			48
-	1	1	1803602-1	SCR, BHSC, RoHS (M8 X 25)			41
-	1	1	1752356-3	SUPPORT, TERMINAL			34
-	2	2	2079383-5	SCR, BHSC, RoHS (M4 X 20)			33
-	2	2	2-2844962-8	SPACER, CYLINDRICAL, STRIP GUIDE			30
-	1	1	2844938-6	PLATE, STRIP GUIDE			29
-	1	1	455888-3	SPACER, CRIMPER			28
-	2	2	22283-1	SPRING, COMPRESSION			27
-	1	1	356835-1	LEVER, DRAG RELEASE			26
-	1	1	240792-1	DRAG, TERMINAL			25
-	1	1	1320928-6	STRIP GUIDE			24
-	1	1	980371-4	SCR, SKT HD SHLDR 5.0 DIA X 6.0			23
-	1	1	2168083-2	SCR, SKT HD CAP, RoHS, M4 X 8.0			21
-	2	2	1-18028-2	WASHER, FLAT, REG M4			20
-	1	1	2119533-1	STRIPPER, SIDE FEED			19
-	1	1	2119806-1	INSERT, SHEAR			13
-	1	1	3-22280-3	SPRING, COMPRESSION			12
-	1	1	1-356885-3	STOP, SHEAR			11
-	1	1	2119805-1	SHEAR HOLDER, FRONT			10
-	1	1	1803095-5	FLOATING SHEAR, FRONT			9
-	1	1	2-1333225-1	ANVIL, COMBINATION			8
-	1	1	4-240641-2	SPACER			7
-	-	-	-	-			6
-	1	1	2119757-8	DEPRESSOR, SHEAR			5
-	1	1	238011-4	BLOCK, CRIMPER SPACER			4
-	1	1	2-1633964-7	CRIMPER, INSULATION OVERLAP PREMIUM			3
-	1	1	455888-3	SPACER, CRIMPER			2
-	1	1	1-1803556-1	CRIMPER, WIRE F			1

PACIFIC VERSION
Shown on sheets 3 of 4 & 4 of 4
(Atlantic version shown on sheets 1 of 4 & 2 of 4)

DIMENSIONS:		TOLERANCES UNLESS OTHERWISE SPECIFIED:		DRAWING NO		RESTRICTED TO	
mm	0 PLC ±0.5	1 PLC ±0.13	2 PLC ±0.013	3 PLC ±0.001	4 PLC ±0.0001	ANGLES ±0.001	FINISH
MATERIAL				WEIGHT		SCALE	
-				-		1:2	

CHK	DATE	DESCRIPTION
H. HUANG	08NOV2012	TE Connectivity Harrisburg, PA 17105-3608
S. XI	08NOV2012	
S. XI	08NOV2012	

ITEM NO	PART NO	DESCRIPTION
-77	-22	-21

SIZE	CAGE CODE	DRAWING NO	REV
A1	00779	2151803	1

Customer Accessible Production Drawing

LOC		DIST		REVISIONS			
A	66	P	LTM	DESCRIPTION	DATE	OWN	APVD
-	-	-	-	SEE SHEET 1	-	-	-

FEED TYPE MECHANICAL

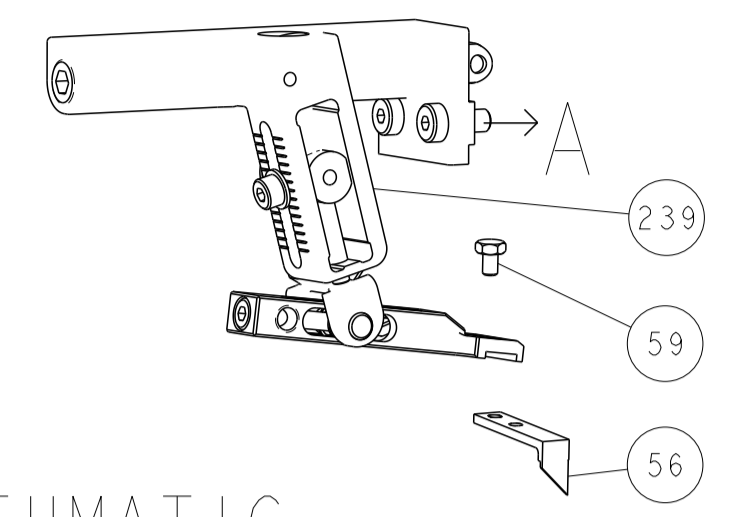

PNEUMATIC

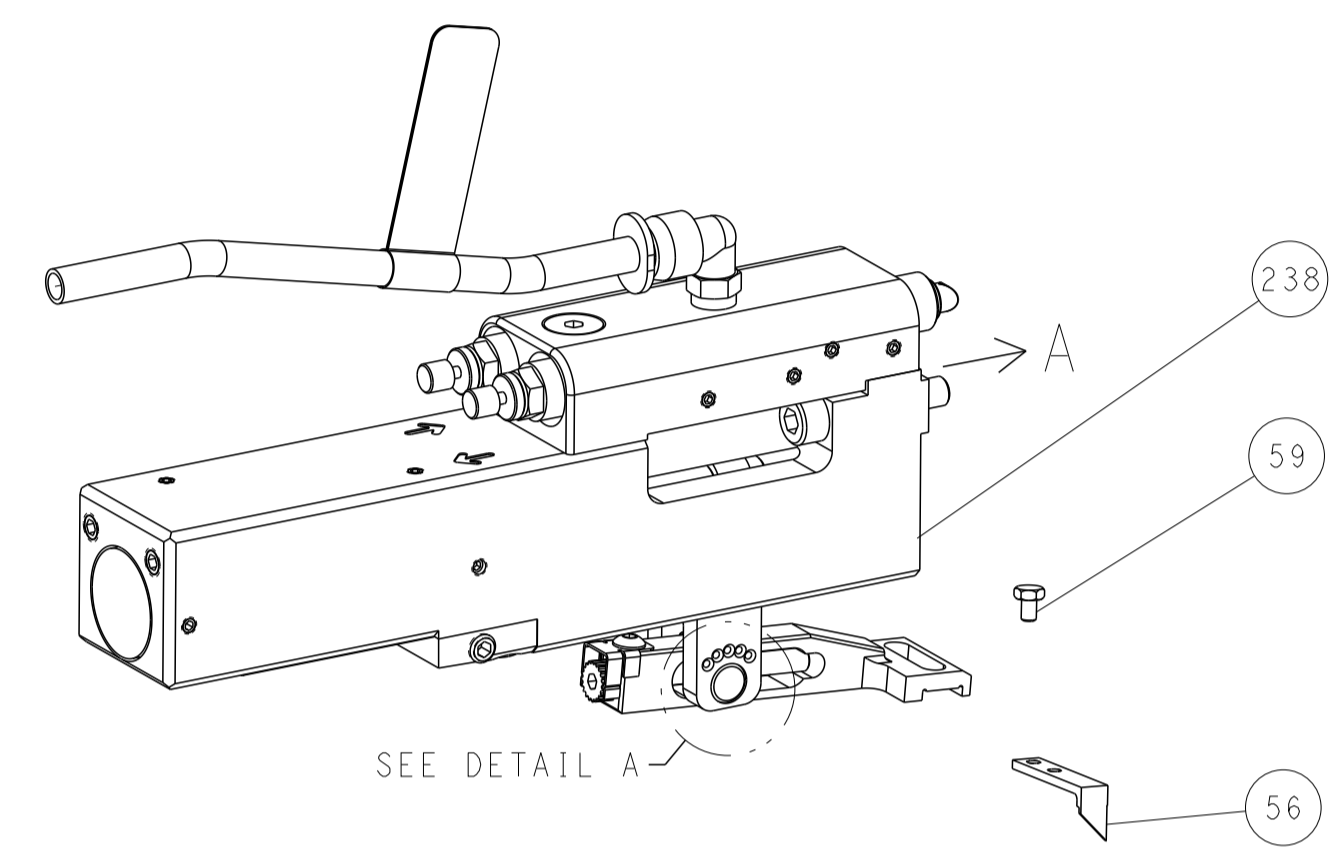

FEED SPRING SETTING POSITION (SHOWN FROM REAR SIDE)



DETAIL A

CAM POSITIONS

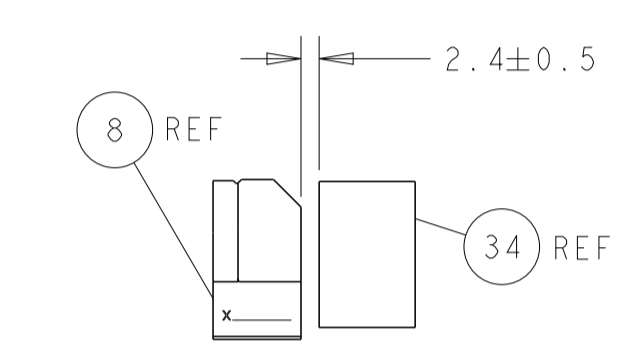
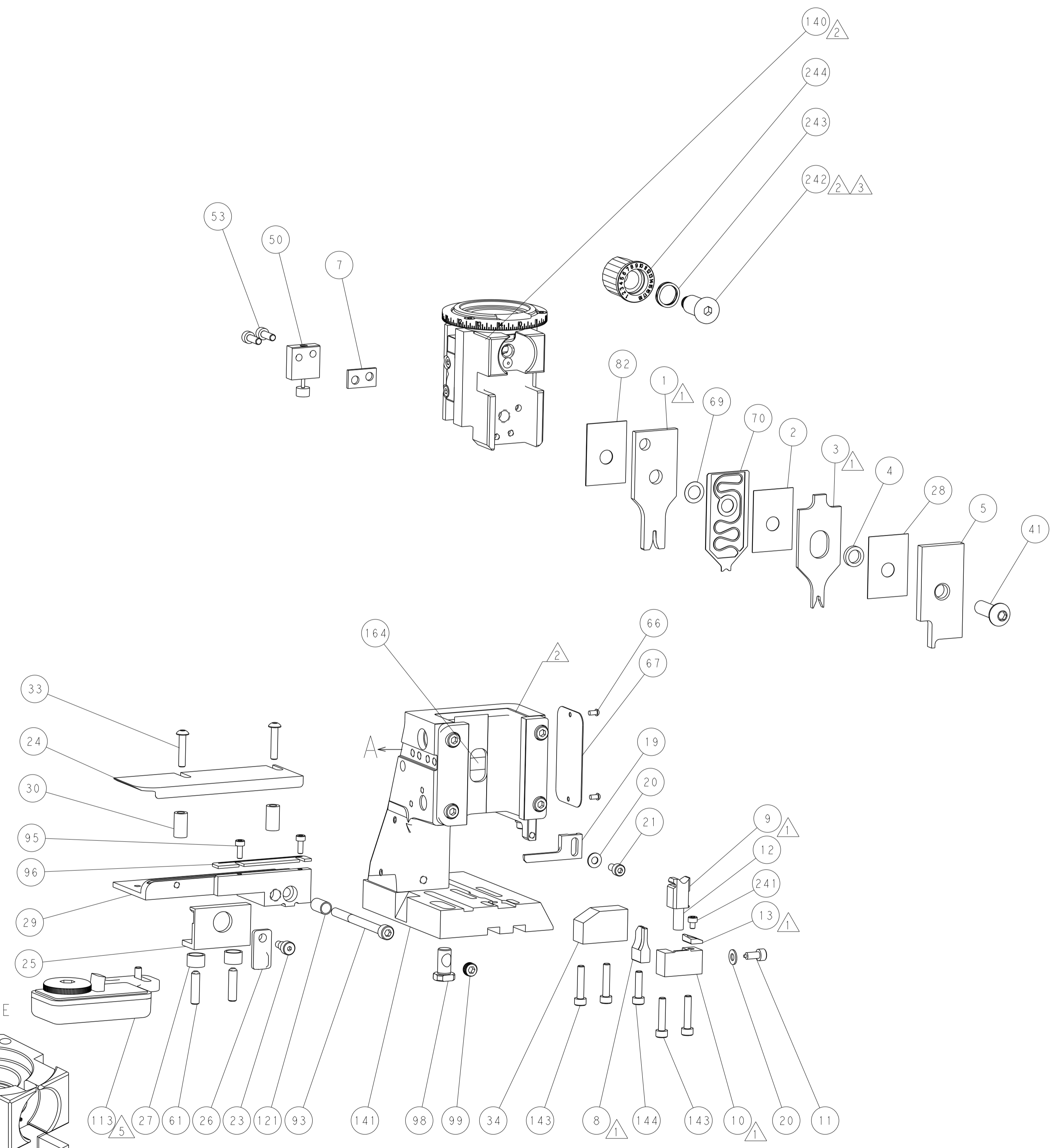
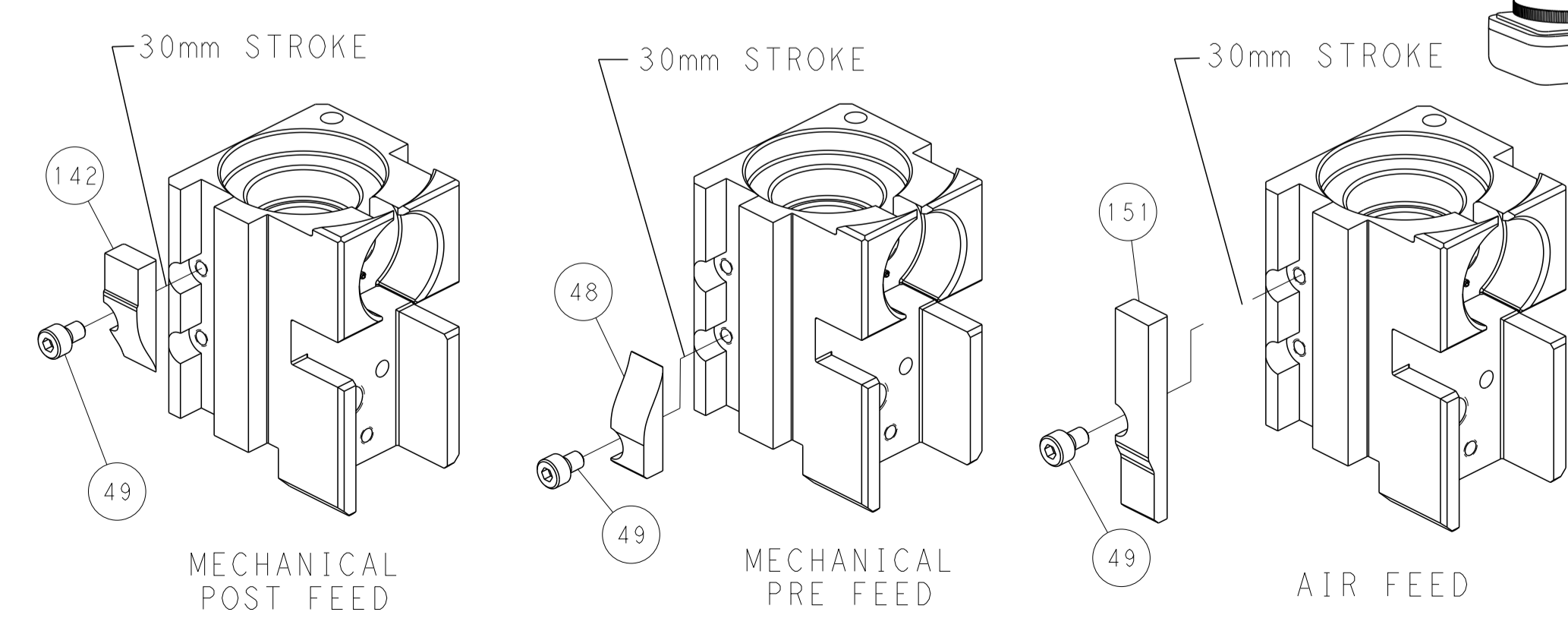

TERMINAL SUPPORT LOCATION

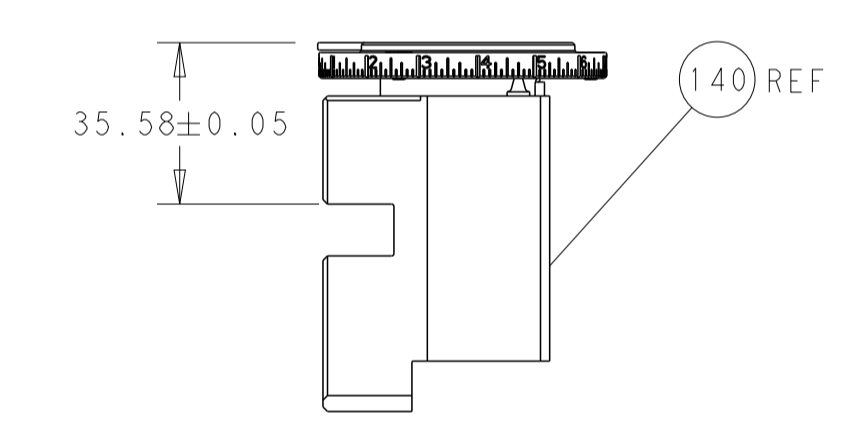

RAM SET-UP

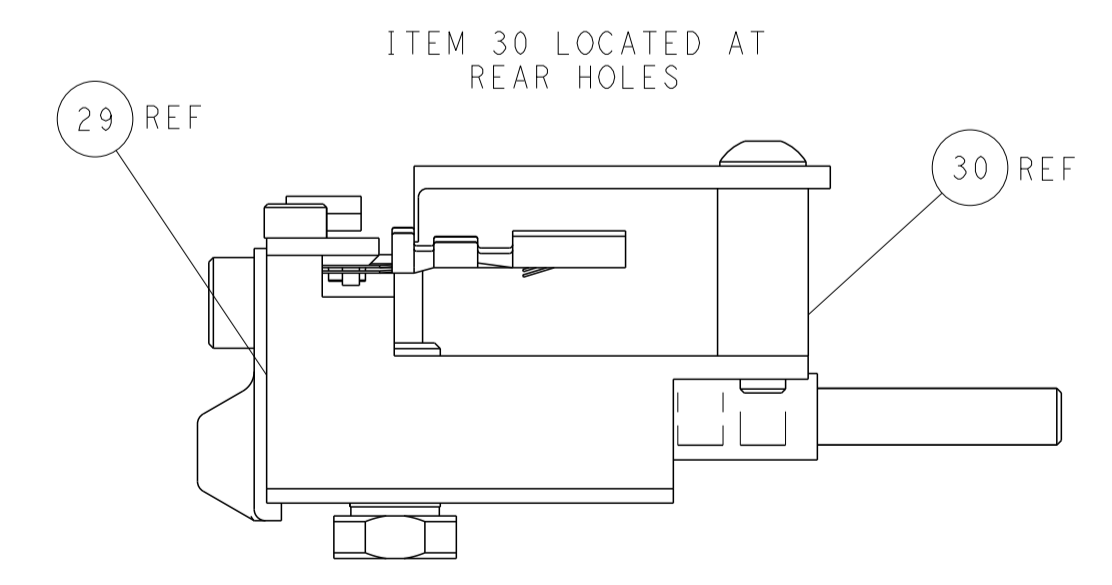

FEED TRACK POSITION GUIDE BY INSULATION BARREL

PACIFIC VERSION
 Shown on sheets 3 of 4 & 4 of 4
 (Atlantic version shown on sheets 1 of 4 & 2 of 4)

<small>THIS DRAWING IS UNPUBLISHED. RELEASED FOR PUBLICATION. ALL RIGHTS RESERVED. THIS IS THE PROPERTY OF TYCO ELECTRONICS CORPORATION. IT IS THE POLICY OF TYCO ELECTRONICS CORPORATION TO CONTINUE TO DEVELOP AND IMPROVE ITS PRODUCTS AND TO MAKE SUCH IMPROVEMENTS AS MAY BE NECESSARY TO MAINTAIN THE HIGHEST QUALITY OF ITS PRODUCTS. THIS DRAWING IS UNPUBLISHED. RELEASED FOR PUBLICATION. ALL RIGHTS RESERVED.</small>		DWN: H. HUANG 08NOV2012 CHK: S. XI 08NOV2012 APVD: S. XI 08NOV2012	TE Connectivity Harrisburg, PA 17105-3608
DIMENSIONS: mm TOLERANCES UNLESS OTHERWISE SPECIFIED: 0 PLC ±0.5 1 PLC ±0.13 2 PLC ±0.13 3 PLC ±0.013 4 PLC ±0.0013 ANGLES FINISH ±		NAME: Ocean Side Feed Applicator PRODUCT SPEC: - APPLICATION SPEC: - SIZE: A1 CAGE CODE: 00779 DRAWING NO: C=2151803	RESTRICTED TO: - SCALE: 1:2 SHEET: 4 OF 4 REV: H1
MATERIAL: - FINISH: -		WEIGHT: - Customer Accessible Production Drawing	SHEETS 1 & 2 ARE NOT REQUIRED FOR PACIFIC VERSION