

PART NUMBER	REVISION	DESCRIPTION	FEED TYPE
2151440-1	E	FINE CRIMP HEIGHT ADJUST	MECHANICAL
2151440-2	F	FINE CRIMP HEIGHT ADJUST	PNEUMATIC
7-2151440-1	E	MECHANICAL AND CRIMP TOOLING KIT	MECHANICAL
7-2151440-2	F	PNEUMATIC AND CRIMP TOOLING KIT	PNEUMATIC
7-2151440-7	B	CRIMP TOOLING KIT	-

ATLANTIC VERSION TERMINATOR INTERFACE ADAPTER

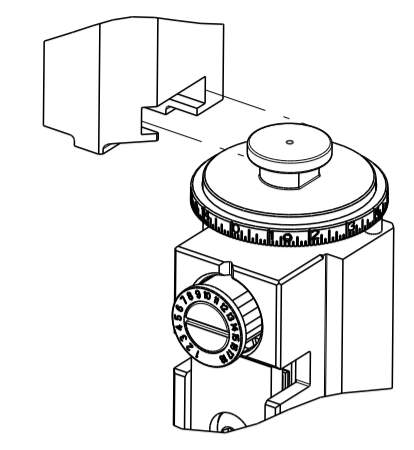

APPLICATOR DATA		
CRIMP	SIZE	TYPE
WIRE	1.00 mm [.039]	F
INSUL	1.60 mm [.063]	F

APPLICATOR INSTRUCTIONS
408-35042

TERMINAL DATA: MOLEX TERMINAL		MOLEX CRIMP SPECIFICATION	
TERMINAL NAME: SL FEMALE CRIMP TERMINAL			
WIRE STRIP LENGTH		INSULATION DIAMETER RANGE	
3.17-3.56 mm [.125-.140 IN]		Ø1.01-1.52 mm [.040-.060 IN]	
TERMINAL APPLICATION SPECIFICATION	ATS-63900-3100 Rev D		
TERMINALS APPLIED			
TE TERMINAL	MOLEX TERMINAL	TE TERMINAL	MOLEX TERMINAL
286784-1	16-02-0069	1572377-1	16-02-0119
286784-2	16-02-0082	1572377-2	16-02-1113
286784-3	16-02-0083	1572377-3	16-02-1112

WIRE SIZE	CRIMP HEIGHT mm [INCH]	CRIMP HEIGHT REFERENCE SETTING
24 AWG	0.815+/-0.025 [.032+/- .001]	5.5
26 AWG	0.765+/-0.025 [.030+/- .001]	5.9
28 AWG	0.735+/-0.025 [.029+/- .001]	6.1
30 AWG	0.685+/-0.025 [.027+/- .001]	6.6

- 1 RECOMMENDED SPARE PARTS
- 2 REFER TO SUPPLIED INSTRUCTION SHEET FOR CLEANING, LUBRICATION AND STORAGE OF APPLICATOR.
- 3 APPLY PART NUMBER 2-23419-6 LOCTITE TO THREADS OF ITEM 242.
- 4 CRIMP HEIGHT REFERENCE SETTING WAS THE SETTING USED WHEN THE APPLICATOR WAS QUALIFIED AT THE FACTORY. ADJUSTMENT MAY BE NECESSARY WHEN RUNNING APPLICATOR IN THE FIELD.
- 5 TERMINAL LUBRICANT IS RECOMMENDED.
- 6. UNLESS SPECIFIED OTHERWISE TORQUE VALUES SHALL BE USED PER DOCUMENT, 101-35000.

***WARNING**
ON INSTALLATION, SET WIRE DISC TO CRIMP HEIGHT REFERENCE SETTING FOR LARGEST WIRE SIZE. CRIMP HEIGHT REFERENCE SETTINGS GREATER THAN THE VALUE SHOWN MAY CAUSE DAMAGE TO THE CRIMP TOOLING. REFER TO THE INSTRUCTION SHEET FOR PROPER SETUP AND ADJUSTMENTS.

ATLANTIC VERSION
Shown on sheets 1 of 4 & 2 of 4
(Pacific version shown on sheets 3 of 4 & 4 of 4)

LOC	DIST	REVISIONS					
A	66	P	LTN	DESCRIPTION	DATE	OWN	APVD
		C		ECR-18-012444	06AUG2018	FL	GB
		D		ECR-18-016100	11OCT2018	TB	CT
		E		ECR-20-007996	04JUN2020	JWC	RK
		F		ECR-21-001237	31JAN2021	TB	RK

-	1	1	1	1	7-18023-7	SCR, SKT HD CAP M3 X 4.0	283	
-	1	1	1	1	2280441-1	INSERT, SHEAR	282	
-	1	-	1	-	2119641-1	FEED CAM, AIR FEED	248	
-	1	1	1	1	2119082-4	CAM, SNAIL, INSULATION ADJUSTMENT	244	
-	1	1	1	1	2079764-1	WASHER, WAVE SPRING, CREST-TO-CREST	243	
-	1	1	1	1	2119083-1	RETAINER, INSULATION DIAL	242	
-	1	1	1	1	7-18023-7	SCR, SKT HD CAP M3 X 4.0	241	
-	-	1	-	1	2119580-1	MECHANICAL FEED ASSEMBLY	239	
-	1	-	1	-	2844940-1	AIR FEED MODULE	238	
-	1	1	1	1	356885-4	STOP, SHEAR	237	
-	REF	REF	REF	REF	994970-2	COUNTER, MAGNETIC	164	
-	1	1	1	1	8-1655316-7	SCR, SKT HD CAP, M5 X 6.5	124	
-	1	1	1	1	2119955-5	ASSY, LUBRICATOR, SIDE FEED	113	
-	1	1	1	1	2844908-1	SCREW, LOCKING	99	
-	1	1	1	1	2844907-1	POST, LOCKING	98	
-	1	1	1	1	1-22281-8	SPRING, COMPRESSION	96	
-	1	1	1	1	980371-4	SCR, SKT HD SHLDR 5.0 DIA X 6.0	83	
-	1	1	1	1	1-455888-0	SPACER, CRIMPER	82	
-	1	1	1	1	240641-1	SPACER	81	
-	1	1	1	1	1803607-3	DOCUMENTATION PACKAGE	71	
-	1	1	1	1	2119791-5	DEPRESSOR, WIRE	70	
-	1	1	1	1	2119740-1	TAG, IDENTIFICATION	67	
-	2	2	2	2	2168078-1	SCREW, DRIVE, RH, RoHS, 2 x .188	66	
-	4	4	4	4	4-1655316-4	SCR, SKT HD CAP, M3 X 8.0	65	
-	2	2	2	2	2-18032-5	SCR, SET, FLT PNT, M5 X 20.0	61	
-	1	1	1	1	2168083-2	SCR, SKT HD CAP, RoHS, M4 X 8.0	60	
-	1	1	1	1	5-18022-5	SCR, HEX HD CAP, M4 X 6.0	59	
-	1	1	1	1	1338683-1	FEED PAWL	56	
-	4	4	4	4	2168083-3	SCR, SKT HD CAP, RoHS, M4 X 12.0	54	
-	2	2	2	2	2168083-8	SCR, SKT HD CAP, RoHS, M4 X 16	53	
-	1	2	1	2	18023-9	SCR, SKT HD CAP M4 X 6.0	49	
-	-	1	-	1	2119652-1	FEED CAM, PRE FEED	48	
-	-	1	-	1	2119653-1	FEED CAM, POST FEED	47	
-	1	1	1	1	1803583-9	APPLICATOR BASIC ASSEMBLY, SF	46	
-	1	1	1	1	1803515-1	RAM ASSEMBLY, SF ATLANTIC	44	
-	1	1	1	1	1803602-1	SCR, BHSC, RoHS (M8 X 25)	41	
-	1	1	1	1	2305692-1	PLATE, REAR STRIP GUIDE	29	
-	2	2	2	2	1-22284-0	SPRING, COMPRESSION	27	
-	1	1	1	1	356835-1	LEVER, DRAG RELEASE	26	
-	1	1	1	1	240792-1	DRAG, TERMINAL	25	
-	1	1	1	1	1-690487-7	GUIDE, FRONT STRIP	24	
-	1	1	1	1	690438-1	FRONT STRIP GUIDE	23	
-	1	1	1	1	2168083-2	SCR, SKT HD CAP, RoHS, M4 X 8.0	21	
-	2	2	2	2	1-18028-2	WASHER, FLAT, REG M4	20	
-	1	1	1	1	2119533-1	STRIPPER, SIDE FEED	19	
-	1	1	1	1	690518-1	HOLD DOWN, TERMINAL	18	
-	1	1	1	1	690463-6	FLOATING SHEAR, REAR	17	
-	2	2	2	2	1-2168083-1	SCR, SKT HD CAP, RoHS, M3 X 6	16	
-	1	1	1	1	2-690464-0	SHEAR PLATE, REAR	15	
-	1	1	1	1	2119862-1	SHEAR HOLDER, REAR	14	
-	1	1	1	1	2119806-1	INSERT, SHEAR	13	
-	2	2	2	2	3-22280-3	SPRING, COMPRESSION	12	
-	1	1	1	1	1-356885-4	STOP, SHEAR	11	
-	1	1	1	1	2119805-1	SHEAR HOLDER, FRONT	10	
-	1	1	1	1	1803095-6	FLOATING SHEAR, FRONT	9	
-	1	2	2	1	1	6-1633139-6	ANVIL, COMBINATION	8
-	1	1	1	1	5-240641-9	SPACER	7	
-	1	1	1	1	1-690468-8	DEPRESSOR SHEAR, REAR	6	
-	1	1	1	1	2119757-2	DEPRESSOR, SHEAR	5	
-	1	1	1	1	238011-9	BLOCK, CRIMPER SPACER	4	
-	1	2	2	1	1	2-1803017-4	CRIMPER, INSULATION F	3
-	-	-	-	-	-	-	2	
-	1	2	2	1	1	2-1633860-5	CRIMPER, WIRE	1
-	77	-72	-71	-2	-1	PART NO	ITEM NO	

DIMENSIONS:		TOLERANCES UNLESS OTHERWISE SPECIFIED:		MATERIAL:	
mm	0 PLC ±	1 PLC ±	2 PLC ±	3 PLC ±	4 PLC ±
	ANGLES ±	FINISH ±			

OWN	C. CHEN	30MAY2012
CHK	S. XI	30MAY2012
APVD	J. CRUZ	30MAY2012
PRODUCT SPEC		
APPLICATION SPEC		
SIZE	A1	00779
CAGE CODE		
DRAWING NO		2151440
RESTRICTED TO		
WEIGHT		
Customer Accessible Production Drawing	SCALE	1:2
SHEET	1	OF 4
REV	F	

LOC	DIST	REVISIONS					
A	66	P	LYN	DESCRIPTION	DATE	DWN	APVD
-	-	-	-	SEE SHEET 1	-	-	-

FEED TYPE MECHANICAL

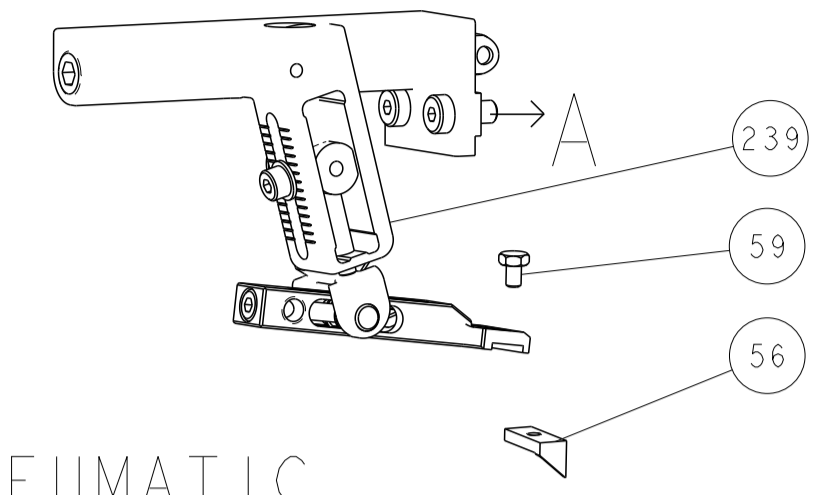

PNEUMATIC

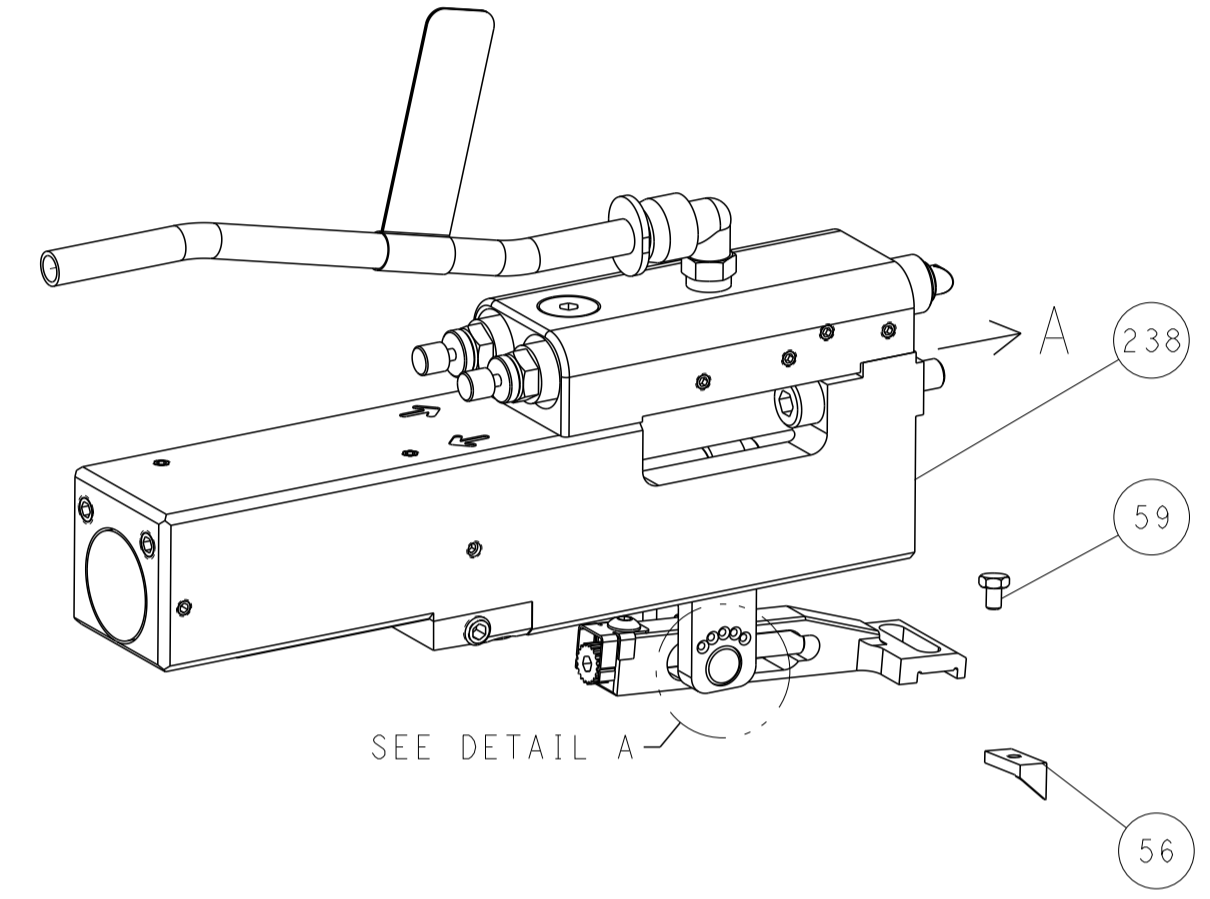

FEED SPRING SETTING POSITION (SHOWN FROM REAR SIDE)

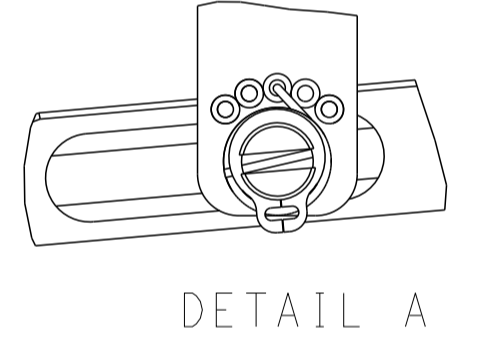

CAM POSITIONS

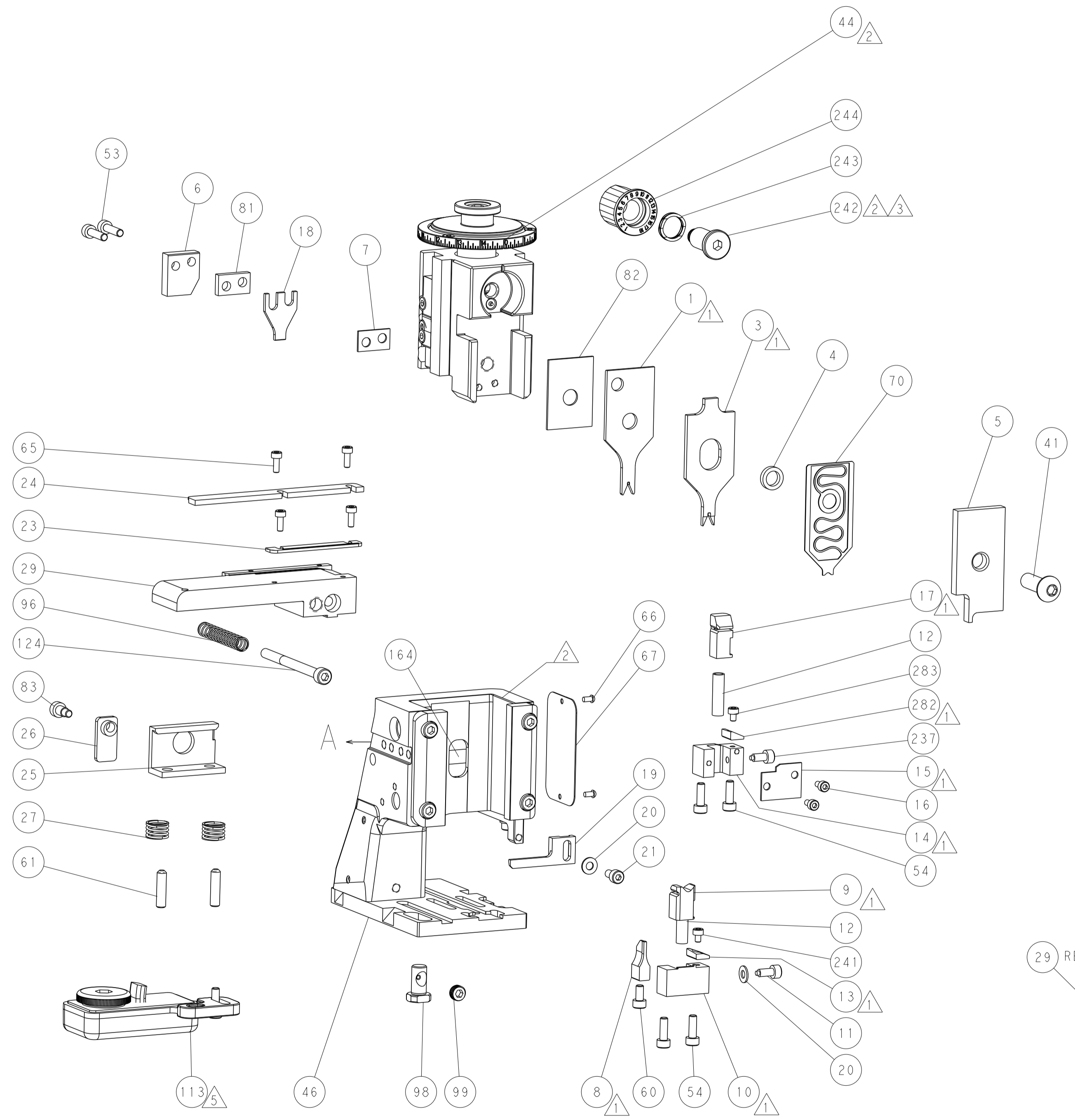
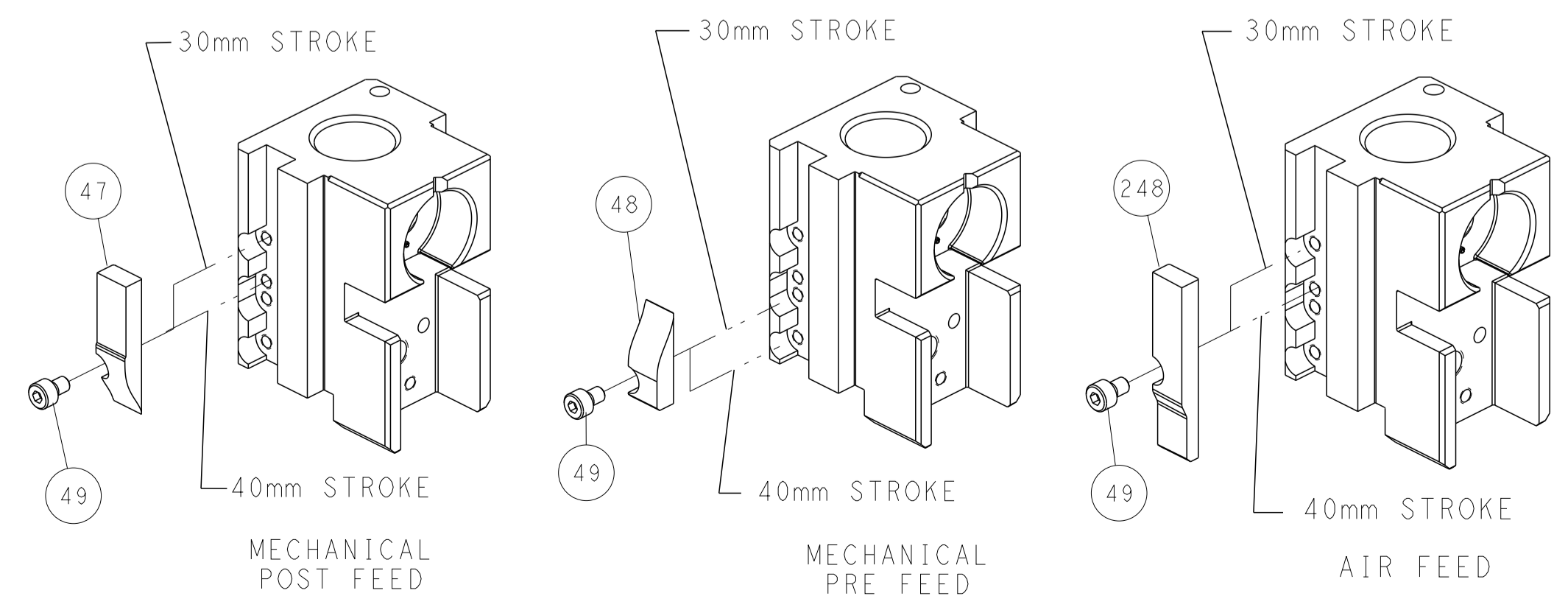

LOC		DIST		REVISIONS			
P	LYN	DESCRIPTION	DATE	DWN	APVD		
A	66	SEE SHEET 1					

FEED TYPE MECHANICAL

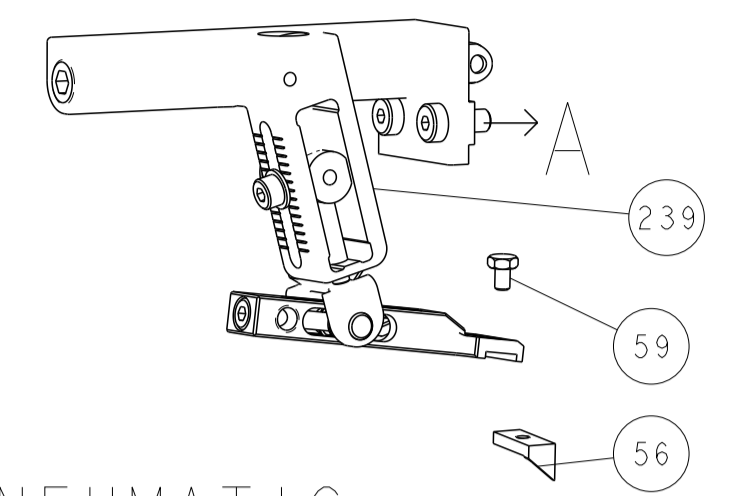

PNEUMATIC

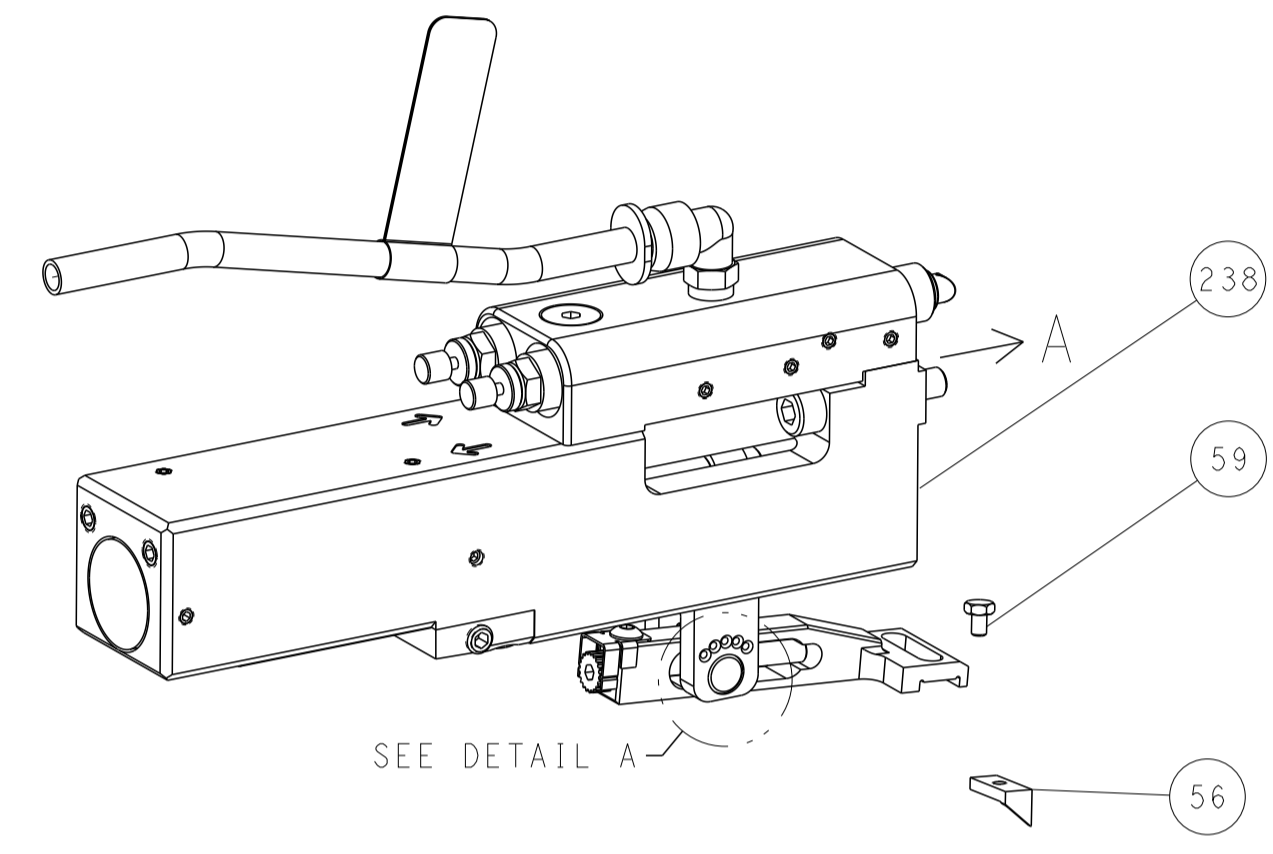

FEED SPRING SETTING POSITION (SHOWN FROM REAR SIDE)

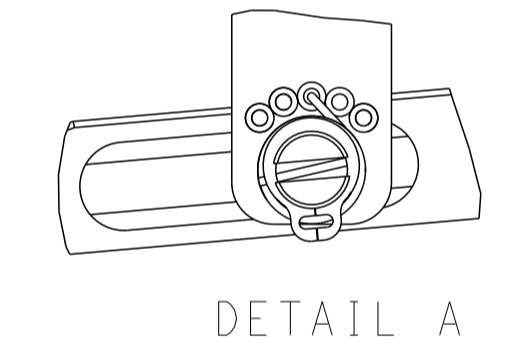

CAM POSITIONS

