

PART NUMBER	REVISION	DESCRIPTION	FEED TYPE
2151216-1	H	FINE CRIMP HEIGHT ADJUST	MECHANICAL
2151216-2	J	FINE CRIMP HEIGHT ADJUST	PNEUMATIC
7-2151216-1	H	MECHANICAL AND CRIMP TOOLING KIT	MECHANICAL
7-2151216-2	J	PNEUMATIC AND CRIMP TOOLING KIT	PNEUMATIC
7-2151216-7	A	CRIMP TOOLING KIT	-

ATLANTIC VERSION TERMINATOR INTERFACE ADAPTER



APPLICATOR DATA		
CRIMP	SIZE	TYPE
WIRE	1.40 mm [.055]	F
INSUL	1.40 mm [.055]	F

APPLICATOR INSTRUCTIONS  
408-35042

TERMINAL DATA: TE TERMINAL		TE CRIMP SPECIFICATION	
TERMINAL NAME: 025 G TAB CONTACT			
WIRE STRIP LENGTH		INSULATION DIAMETER RANGE	
3.00-3.50 mm [.118-.138 IN]		Ø1.10-1.70 mm [.043-.067 IN]	
TERMINAL APPLICATION SPECIFICATION	114-5340		
TERMINALS APPLIED			
TE TERMINAL	TE TERMINAL	TE TERMINAL	TE TERMINAL
1674742-1			

TERMINAL DATA: TE TERMINAL		TE CRIMP SPECIFICATION	
TERMINAL NAME: 025 G TAB CONTACT			
WIRE STRIP LENGTH		INSULATION DIAMETER RANGE	
3.00-3.50 mm [.118-.138 IN]		Ø1.20-1.60 mm [.047-.063 IN]	
TERMINAL APPLICATION SPECIFICATION	114-15120		
TERMINALS APPLIED			
TE TERMINAL	TE TERMINAL	TE TERMINAL	TE TERMINAL
1674742-1	2005154-1	2005154-2	1802190-1

TERMINAL DATA: TE TERMINAL		TE CRIMP SPECIFICATION	
TERMINAL NAME: 025 G TAB CONTACT			
WIRE STRIP LENGTH		INSULATION DIAMETER RANGE	
3.00-3.50 mm [.118-.138 IN]		Ø1.40-1.70 mm [.055-.067 IN]	
TERMINAL APPLICATION SPECIFICATION	114-61030		
TERMINALS APPLIED			
TE TERMINAL	TE TERMINAL	TE TERMINAL	TE TERMINAL
2005427-1	2188446-2	2366531-2	2005154-1
2005154-2	2188445-2		

WIRE SIZE	CRIMP HEIGHT mm [INCH]	CRIMP HEIGHT REFERENCE SETTING
0.50mm2	1.01+/-0.05 [.040+/- .002]	6.9
0.30mm2	0.96+/-0.05 [.038+/- .002]	7.4

WIRE SIZE	CRIMP HEIGHT mm [INCH]	CRIMP HEIGHT REFERENCE SETTING
0.50mm2	0.99+/-0.03 [.039+/- .001]	7.8
0.35mm2	0.92+/-0.03 [.036+/- .001]	5.8
0.22mm2	0.84+/-0.03 [.033+/- .001]	6.6

WIRE SIZE	CRIMP HEIGHT mm [INCH]	CRIMP HEIGHT REFERENCE SETTING
0.50mm2	1.01+/-0.05 [.040+/- .002]	6.9
0.30mm2	0.96+/-0.05 [.038+/- .002]	7.4

- RECOMMENDED SPARE PARTS
- REFER TO SUPPLIED INSTRUCTION SHEET FOR CLEANING, LUBRICATION AND STORAGE OF APPLICATOR.
- APPLY PART NUMBER 2-23419-6 LOCTITE TO THREADS OF ITEM 242.
- CRIMP HEIGHT REFERENCE SETTING WAS THE SETTING USED WHEN THE APPLICATOR WAS QUALIFIED AT THE FACTORY. ADJUSTMENT MAY BE NECESSARY WHEN RUNNING APPLICATOR IN THE FIELD.
- TERMINAL LUBRICANT IS RECOMMENDED.
- 6. UNLESS SPECIFIED OTHERWISE TORQUE VALUES SHALL BE USED PER DOCUMENT, 101-35000.-
- APPLICATION SPECIFICATION 114-15120 IS RESTRICTED TO RENAULT AND ITS HARNESS MAKERS.

**\*WARNING**  
ON INSTALLATION, SET WIRE DISC TO CRIMP HEIGHT REFERENCE SETTING FOR LARGEST WIRE SIZE. CRIMP HEIGHT REFERENCE SETTINGS GREATER THAN THE VALUE SHOWN MAY CAUSE DAMAGE TO THE CRIMP TOOLING, REFER TO THE INSTRUCTION SHEET FOR PROPER SETUP AND ADJUSTMENTS.

LOC	DIST	REVISIONS					
A	66	P	LTN	DESCRIPTION	DATE	OWN	APVD
		J		ECR-19-009948	25JUN2019	JAH	TE
		J1		ECR-21-006791	09JUL2021	FJ	RK
		J2		ECR-21-007109	02AUG2021	AJ	YY
		J3		ECR-23-182529	28JUL2023	FZ	TE

-	1	-	1	-	2119641-1	FEED CAM, AIR FEED	248	
-	1	1	1	1	2119082-8	CAM, SNAIL, INSULATION ADJUSTMENT	244	
-	1	1	1	1	2079764-1	WASHER, WAVE SPRING, CREST-TO-CREST	243	
-	1	1	1	1	2119083-1	RETAINER, INSULATION DIAL	242	
-	1	1	1	1	7-18023-7	SCR, SKT HD CAP M3 X 4.0	241	
-	-	1	-	1	2119580-1	MECHANICAL FEED ASSEMBLY	239	
-	1	-	1	-	2844940-1	AIR FEED MODULE	238	
-	REF	REF	REF	REF	994970-2	COUNTER, MAGNETIC	164	
-	1	1	1	1	2119955-1	ASSY, LUBRICATOR, SIDE FEED	113	
-	1	1	1	1	2844908-1	SCREW, LOCKING	99	
-	1	1	1	1	2844907-1	POST, LOCKING	98	
-	1	1	1	1	455888-5	SPACER, CRIMPER	82	
-	1	1	1	1	1803607-3	DOCUMENTATION PACKAGE	71	
-	1	1	1	1	2119791-9	DEPRESSOR, WIRE	70	
-	1	1	1	1	2119740-1	TAG IDENTIFICATION	67	
-	2	2	2	2	2168078-1	SCREW, DRIVE, RH, RoHS, 2 x .188	66	
-	1	1	1	1	2168083-2	SCR, SKT HD CAP, RoHS, M4 X 8.0	60	
-	1	1	1	1	5-18022-5	SCR, HEX HD CAP, M4 X 6.0	59	
-	1	1	1	1	1338685-1	PAWL, FEED	56	
-	4	4	4	4	2168083-3	SCR, SKT HD CAP, RoHS, M4 X 12.0	54	
-	2	2	2	2	2-2168083-6	SCR, SKT HD CAP, RoHS, M4 X 18	53	
-	1	1	1	1	1803382-6	HOLD DOWN, SPRING LOADED	50	
-	1	2	1	2	18023-9	SCR, SKT HD CAP M4 X 6.0	49	
-	-	1	-	1	2119652-1	FEED CAM, PRE FEED	48	
-	-	1	-	1	2119653-1	FEED CAM, POST FEED	47	
-	1	1	1	1	1803583-9	APPLICATOR BASIC ASSEMBLY, SF	46	
-	1	1	1	1	1803515-1	RAM ASSEMBLY, SF ATLANTIC	44	
-	1	1	1	1	1803602-1	SCR, BHSC, RoHS (M8 X 25)	41	
-	1	1	1	1	1-1752356-9	SUPPORT, TERMINAL	34	
-	2	2	2	2	2079383-5	SCR, BHSC, RoHS (M4 X 20)	33	
-	2	2	2	2	2-2844962-4	SPACER, CYLINDRICAL, STRIP GUIDE	30	
-	1	1	1	1	2844992-1	ASSEMBLY, STRIP GUIDE	29	
-	1	1	1	1	1320928-2	STRIP GUIDE	24	
-	1	1	1	1	2168083-2	SCR, SKT HD CAP, RoHS, M4 X 8.0	21	
-	2	2	2	2	1-18028-2	WASHER, FLAT, REG M4	20	
-	1	1	1	1	2119533-1	STRIPPER, SIDE FEED	19	
-	1	1	1	1	2119806-1	INSERT, SHEAR	13	
-	1	1	1	1	3-22280-3	SPRING, COMPRESSION	12	
-	1	1	1	1	1-356885-3	STOP, SHEAR	11	
-	1	1	1	1	2119805-1	SHEAR HOLDER, FRONT	10	
-	1	1	1	1	1633861-1	SHEAR, FLOATING	9	
-	1	2	2	1	1	7-1333201-1	ANVIL, COMBINATION	8
-	1	1	1	1	6-240641-8	SPACER	7	
-	-	-	-	-	-	-	6	
-	1	1	1	1	1-2119757-1	DEPRESSOR, SHEAR	5	
-	1	1	1	1	1-238011-0	BLOCK, CRIMPER SPACER	4	
-	1	2	2	1	1	1633962-2	CRIMPER, INSULATION F PREMIUM	3
-	1	1	1	1	455888-2	SPACER, CRIMPER	2	
-	1	2	2	1	1	456402-1	CRIMPER, WIRE PREMIUM	1

ATLANTIC VERSION  
Shown on sheets 1 of 4 & 2 of 4  
(Pacific version shown on sheets 3 of 4 & 4 of 4)

DIMENSIONS:		TOLERANCES UNLESS OTHERWISE SPECIFIED:		MATERIAL:	
mm	0 PLC ±	1 PLC ±	2 PLC ±	3 PLC ±	4 PLC ±
	ANGLES ±	FINISH ±			

OWN	CHK	APVD	DATE	NAME	SIZE	CAGE CODE	DRAWING NO	RESTRICTED TO
L. ZHANG	L. ZHANG	S. XI	10AUG2011	Ocean Side Feed Applicator	A1	00779	2151216	-

Customer Accessible Production Drawing SCALE 1:2 SHEET 1 OF 4 REV J3

LOC	DIST	REVISIONS					
A	66	P	LYN	DESCRIPTION	DATE	OWN	APVD
		-		SEE SHEET 1			

# FEED TYPE MECHANICAL



## PNEUMATIC

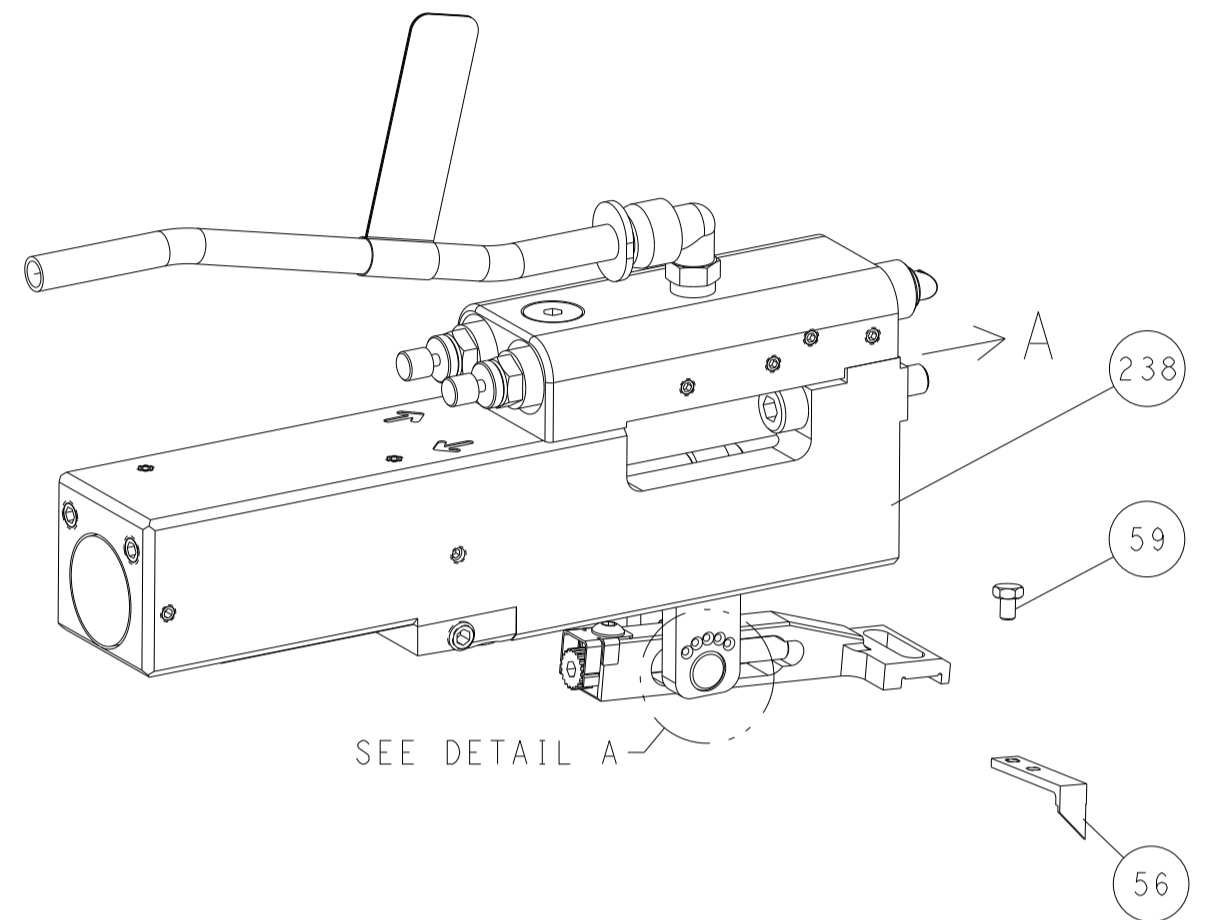

## FEED SPRING SETTING POSITION (SHOWN FROM REAR SIDE)



DETAIL A

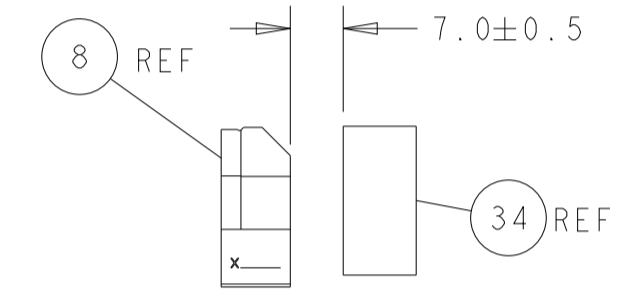
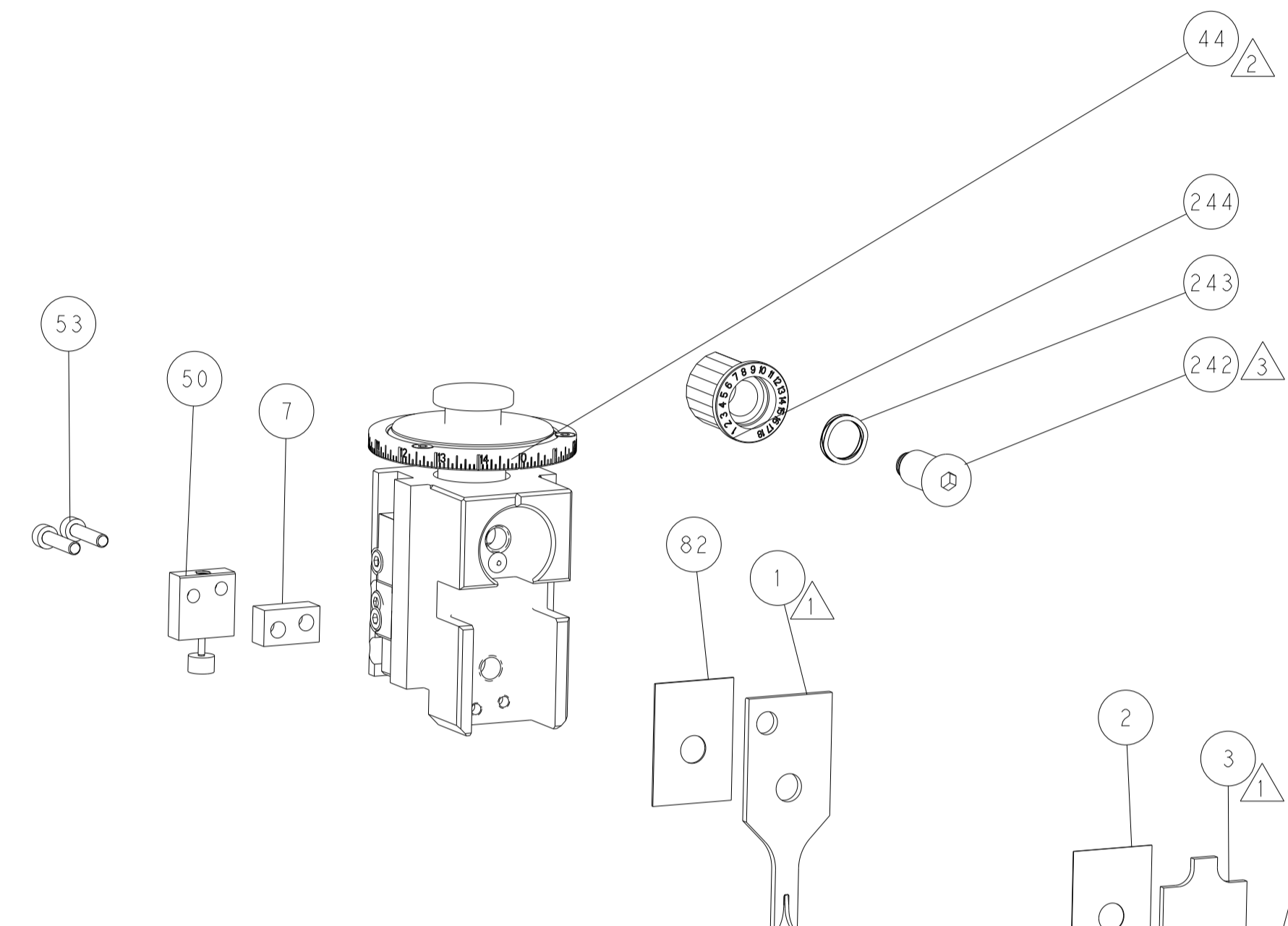

TERMINAL SUPPORT LOCATION

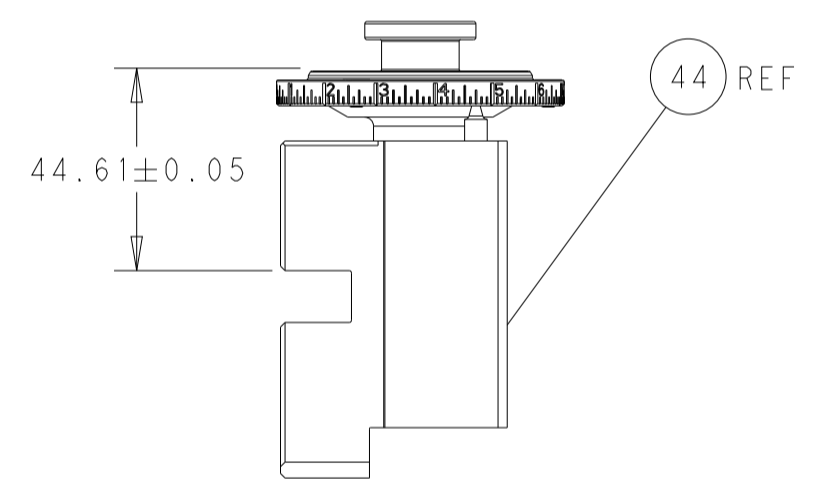

RAM SET-UP

ITEM 30 LOCATED AT FRONT HOLES

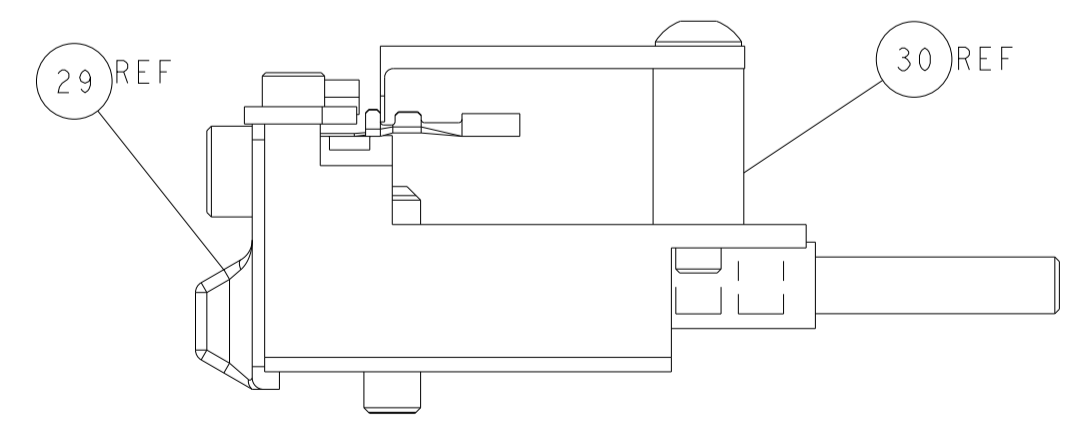

FEED TRACK POSITION GUIDE BY INSULATION BARREL

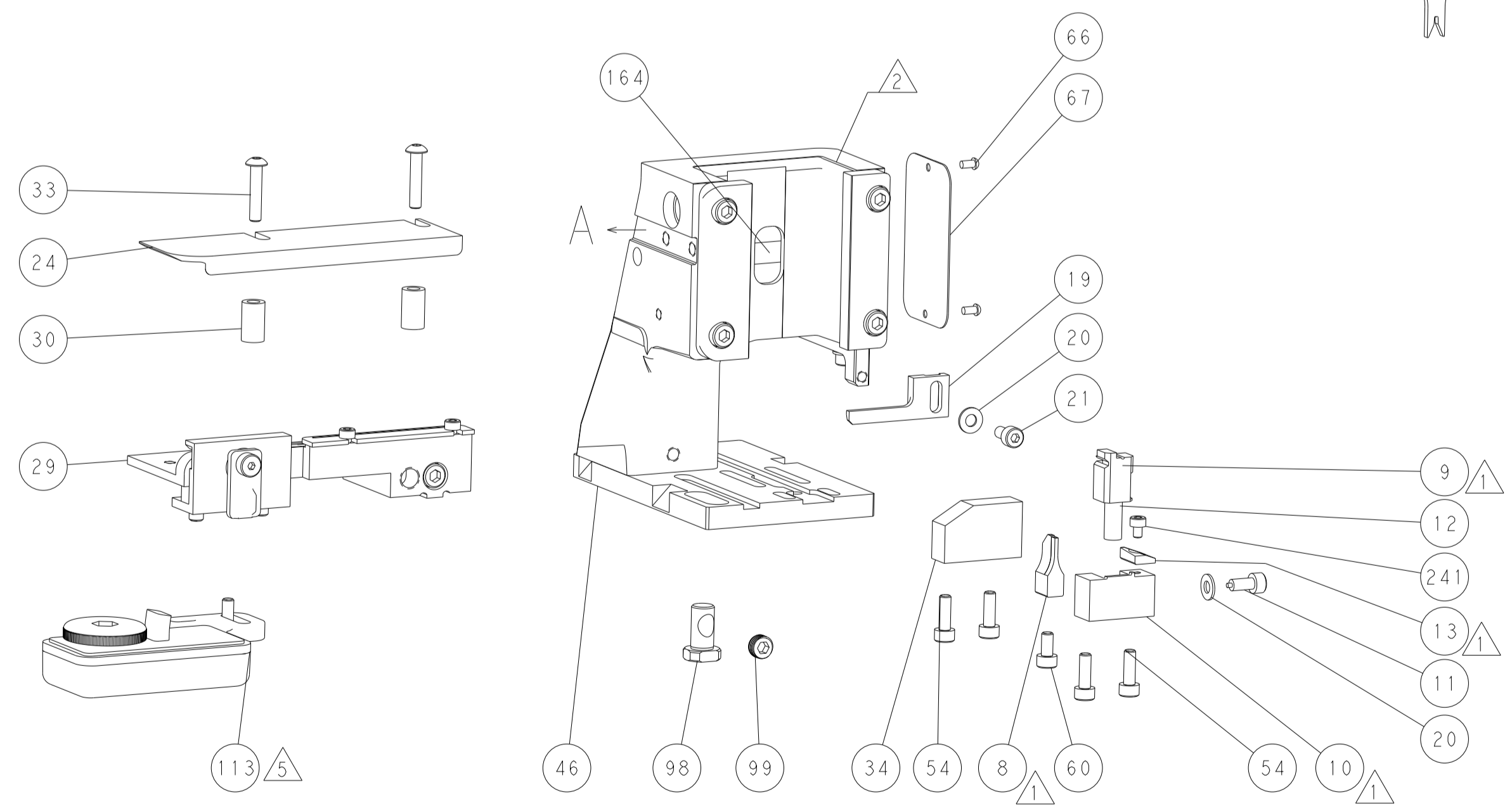

# CAM POSITIONS

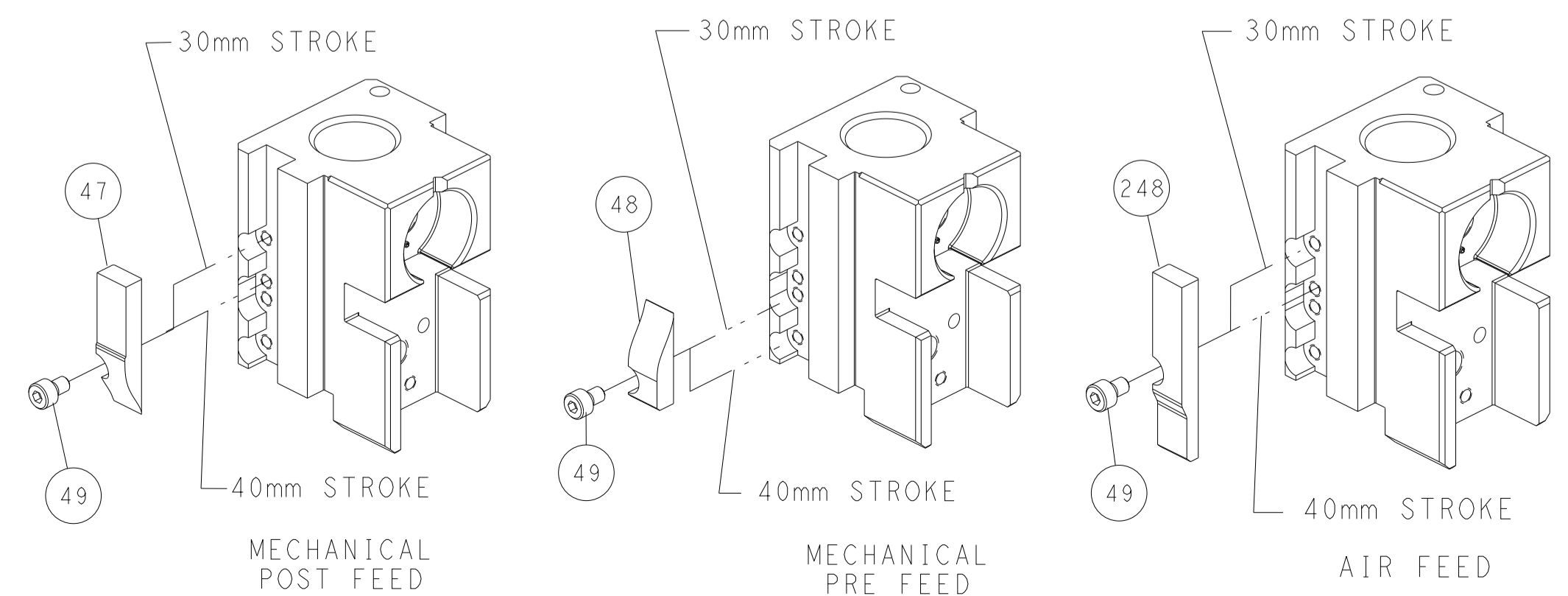

**ATLANTIC VERSION**  
 Shown on sheets 1 of 4 & 2 of 4  
 (Pacific version shown on sheets 3 of 4 & 4 of 4)

<small>THIS DRAWING IS UNPUBLISHED. RELEASED FOR PUBLICATION. ALL RIGHTS RESERVED. © 2011 BY TYCO ELECTRONICS CORPORATION. THIS DRAWING IS CONTROLLED DOCUMENT. FOR THE ELECTRONICS CORPORATION. IT IS THE PROPERTY OF TYCO ELECTRONICS CORPORATION AND IS NOT TO BE REPRODUCED OR TRANSMITTED IN ANY FORM OR BY ANY MEANS, ELECTRONIC OR MECHANICAL, INCLUDING PHOTOCOPYING, RECORDING, OR BY ANY INFORMATION STORAGE AND RETRIEVAL SYSTEM, WITHOUT THE WRITTEN PERMISSION OF TYCO ELECTRONICS CORPORATION.</small>		DWN L. ZHANG 10AUG2011 CHK L. ZHANG 10AUG2011 S. XI 10AUG2011 APVD S. XI 10AUG2011	TE Connectivity Harrisburg, PA 17105-3608
DIMENSIONS: mm TOLERANCES UNLESS OTHERWISE SPECIFIED: 0 PLC ± 1 PLC ± 2 PLC ± 3 PLC ± 4 PLC ± ANGLES FINISH ±		NAME Ocean Side Feed Applicator PRODUCT SPEC APPLICATION SPEC WEIGHT SCALE 1:2 SHEET 2 OF 4 REV J3	SIZE CAGE CODE DRAWING NO A1 00779 C=2151216 RESTRICTED TO
MATERIAL:		Customer Accessible Production Drawing	

THIS DRAWING IS UNPUBLISHED.	RELEASED FOR PUBLICATION		
COPYRIGHT 20 BY TYCO ELECTRONICS CORPORATION. ALL RIGHTS RESERVED.			
PART NUMBER	REVISION	DESCRIPTION	FEED TYPE
2-2151216-1	H	FINE CRIMP HEIGHT ADJUST	MECHANICAL
2-2151216-2	J	FINE CRIMP HEIGHT ADJUST	PNEUMATIC
7-2151216-7	A	CRIMP TOOLING KIT	-

PACIFIC VERSION TERMINATOR  
INTERFACE ADAPTER



APPLICATOR DATA		
CRIMP	SIZE	TYPE
WIRE	1.40 mm [.055]	F
INSUL	1.40 mm [.055]	F
APPLICATOR INSTRUCTIONS 408-35042		

TERMINAL DATA: TE TERMINAL		TE CRIMP SPECIFICATION	
TERMINAL NAME: 025 G TAB CONTACT			
WIRE STRIP LENGTH		INSULATION DIAMETER RANGE	
3.00-3.50 mm [.118-.138 IN]		Ø1.10-1.70 mm [.043-.067 IN]	
TERMINAL APPLICATION SPECIFICATION	114-5340	-	-
TERMINALS APPLIED			
TE TERMINAL	TE TERMINAL	TE TERMINAL	TE TERMINAL
1674742-1			

TERMINAL DATA: TE TERMINAL		TE CRIMP SPECIFICATION	
TERMINAL NAME: 025 G TAB CONTACT			
WIRE STRIP LENGTH		INSULATION DIAMETER RANGE	
3.00-3.50 mm [.118-.138 IN]		Ø1.20-1.60 mm [.047-.063 IN]	
TERMINAL APPLICATION SPECIFICATION	114-15120	-	-
TERMINALS APPLIED			
TE TERMINAL	TE TERMINAL	TE TERMINAL	TE TERMINAL
1674742-1	2005154-1	2005154-2	1802190-1

TERMINAL DATA: TE TERMINAL		TE CRIMP SPECIFICATION	
TERMINAL NAME: 025 G TAB CONTACT			
WIRE STRIP LENGTH		INSULATION DIAMETER RANGE	
3.00-3.50 mm [.118-.138 IN]		Ø1.40-1.70 mm [.055-.067 IN]	
TERMINAL APPLICATION SPECIFICATION	114-61030	-	-
TERMINALS APPLIED			
TE TERMINAL	TE TERMINAL	TE TERMINAL	TE TERMINAL
2005427-1	2188446-2	2366531-2	2005154-1
2005154-2	2188445-2		

WIRE SIZE	CRIMP HEIGHT mm [INCH]	CRIMP HEIGHT REFERENCE SETTING
0.50mm2	1.01 +/- 0.05 [.040 +/- .002]	6.9
0.30mm2	0.96 +/- 0.05 [.038 +/- .002]	7.4

WIRE SIZE	CRIMP HEIGHT mm [INCH]	CRIMP HEIGHT REFERENCE SETTING
0.50mm2	0.99 +/- 0.03 [.039 +/- .001]	7.8
0.35mm2	0.92 +/- 0.03 [.036 +/- .001]	5.8
0.22mm2	0.84 +/- 0.03 [.033 +/- .001]	6.6

WIRE SIZE	CRIMP HEIGHT mm [INCH]	CRIMP HEIGHT REFERENCE SETTING
0.50mm2	1.01 +/- 0.05 [.040 +/- .002]	6.9
0.30mm2	0.96 +/- 0.05 [.038 +/- .002]	7.4

- RECOMMENDED SPARE PARTS
- REFER TO SUPPLIED INSTRUCTION SHEET FOR CLEANING, LUBRICATION AND STORAGE OF APPLICATOR.
- APPLY PART NUMBER 2-23419-6 LOCTITE TO THREADS OF ITEM 242.
- CRIMP HEIGHT REFERENCE SETTING WAS THE SETTING USED WHEN THE APPLICATOR WAS QUALIFIED AT THE FACTORY. ADJUSTMENT MAY BE NECESSARY WHEN RUNNING APPLICATOR IN THE FIELD.
- TERMINAL LUBRICANT IS RECOMMENDED.
- 6. UNLESS SPECIFIED OTHERWISE TORQUE VALUES SHALL BE USED PER DOCUMENT, 101-35000.
- APPLICATION SPECIFICATION 114-15120 IS RESTRICTED TO RENAULT AND ITS HARNESS MAKERS.

**\*WARNING**  
ON INSTALLATION, SET WIRE DISC TO CRIMP HEIGHT REFERENCE SETTING FOR LARGEST WIRE SIZE. CRIMP HEIGHT REFERENCE SETTINGS GREATER THAN THE VALUE SHOWN MAY CAUSE DAMAGE TO THE CRIMP TOOLING, REFER TO THE INSTRUCTION SHEET FOR PROPER SETUP AND ADJUSTMENTS.

ENTRY LEVEL APPLICATOR		ITEM SUBSTITUTION LIST		
PART NUMBER	SAME AS	ITEM	ITEM DESCRIPTION	SUBSTITUTE PART NUMBER
8-2151216-1	2151216-1	1	WIRE CRIMPER	1803530-1
8-2151216-2	2151216-2	3	INSULATION CRIMPER	1803635-2
9-2151216-1	2-2151216-1	46	BASIC SUB -ASSEMBLY	1803940-9
9-2151216-2	2-2151216-2	141	BASIC SUB -ASSEMBLY	1-1803940-0
			LUBRICATOR	DELETE

**PACIFIC VERSION**  
Shown on sheets 3 of 4 & 4 of 4  
(Atlantic version shown on sheets 1 of 4 & 2 of 4)

LOC	DIST	REVISIONS					
A	66	P	LTN	DESCRIPTION	DATE	OWN	APVD
		-	-	SEE SHEET 1	-	-	-

-	1	1	2119082-8	CAM, SNAIL, INSULATION ADJUSTMENT	244	
-	1	1	2079764-1	WASHER, WAVE SPRING, CREST-TO-CREST	243	
	-	1	2119083-1	RETAINER, INSULATION DIAL	242	
-	1	1	7-18023-7	SCR, SKT HD CAP M3 X 4.0	241	
-	-	1	2119580-1	MECHANICAL FEED ASSEMBLY	239	
-	1	-	2844940-1	AIR FEED MODULE	238	
-	REF	REF	994970-2	COUNTER, MAGNETIC	164	
-	1	-	2119641-2	FEED CAM, AIR FEED	151	
-	1	1	2168083-8	SCR, SKT HD CAP, RoHS, M4 X 16	144	
-	4	4	2168083-9	SCR, SKT HD CAP, RoHS, M4 X 20	143	
-	-	1	2119653-2	FEED CAM, POST FEED	142	
-	1	1	1-1803583-0	APPLICATOR BASIC ASSEMBLY, SF	141	
-	1	1	1803516-1	RAM ASSEMBLY, SF PACIFIC	140	
	-	1	2119955-1	ASSY, LUBRICATOR, SIDE FEED	113	
-	1	1	2844908-1	SCREW, LOCKING	99	
-	1	1	2844907-1	POST, LOCKING	98	
-	1	1	455888-5	SPACER, CRIMPER	82	
-	1	1	1803607-3	DOCUMENTATION PACKAGE	71	
-	1	1	2119791-9	DEPRESSOR, WIRE	70	
-	1	1	2119740-1	TAG, IDENTIFICATION	67	
-	2	2	2168078-1	SCREW, DRIVE, RH, RoHS, 2 x .188	66	
-	1	1	5-18022-5	SCR, HEX HD CAP, M4 X 6.0	59	
-	1	1	1338685-1	PAWL, FEED	56	
-	2	2	2-2168083-6	SCR, SKT HD CAP, RoHS, M4 X 18	53	
-	1	1	1803382-6	HOLD DOWN, SPRING LOADED	50	
-	1	2	18023-9	SCR, SKT HD CAP M4 X 6.0	49	
-	-	1	2119652-1	FEED CAM, PRE FEED	48	
-	1	1	1803602-1	SCR, BHSC, RoHS (M8 X 25)	41	
-	1	1	1-1752356-9	SUPPORT, TERMINAL	34	
-	2	2	2079383-5	SCR, BHSC, RoHS (M4 X 20)	33	
-	2	2	2-2844962-4	SPACER, CYLINDRICAL, STRIP GUIDE	30	
-	1	1	2844992-1	ASSEMBLY, STRIP GUIDE	29	
-	1	1	1320928-2	STRIP GUIDE	24	
-	1	1	2168083-2	SCR, SKT HD CAP, RoHS, M4 X 8.0	21	
-	2	2	1-18028-2	WASHER, FLAT, REG M4	20	
-	1	1	2119533-1	STRIPPER, SIDE FEED	19	
	-	1	2119806-1	INSERT, SHEAR	13	
-	1	1	3-22280-3	SPRING, COMPRESSION	12	
-	1	1	1-356885-3	STOP, SHEAR	11	
	-	1	2119805-1	SHEAR HOLDER, FRONT	10	
	-	1	1633861-1	SHEAR, FLOATING	9	
	1	1	1	7-1333201-1	ANVIL, COMBINATION	8
-	1	1	6-240641-8	SPACER	7	
-	-	-	-	-	6	
-	1	1	1-2119757-1	DEPRESSOR, SHEAR	5	
-	1	1	1-238011-0	BLOCK, CRIMPER SPACER	4	
	1	1	1	1633962-2	CRIMPER, INSULATION F PREMIUM	3
-	1	1	455888-2	SPACER, CRIMPER	2	
	1	1	1	456402-1	CRIMPER, WIRE PREMIUM	1

DIMENSIONS:		TOLERANCES UNLESS OTHERWISE SPECIFIED:	
mm	0 PLC ±	1 PLC ±	2 PLC ±
	3 PLC ±	4 PLC ±	ANGLES ±
	FINISH		
MATERIAL		WEIGHT	
Customer Accessible Production Drawing		SCALE	1:2
SHEET		3	OF 4
REV		J3	

LOC	DIST	REVISIONS					
A	66	P	LYN	DESCRIPTION	DATE	OWN	APVD
		-		SEE SHEET 1			

# FEED TYPE MECHANICAL

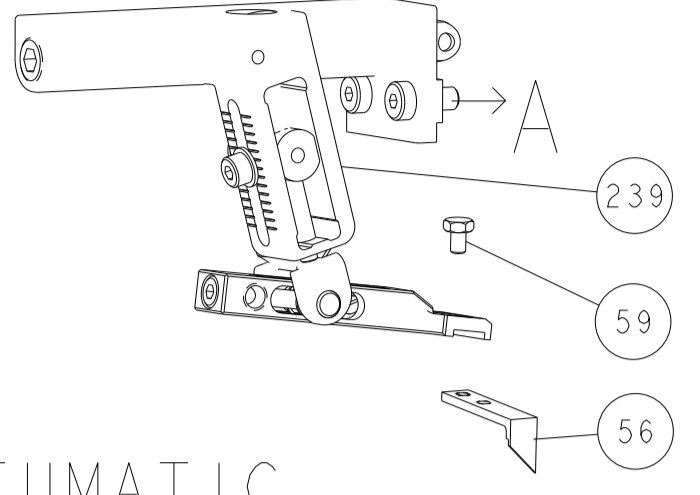

## PNEUMATIC

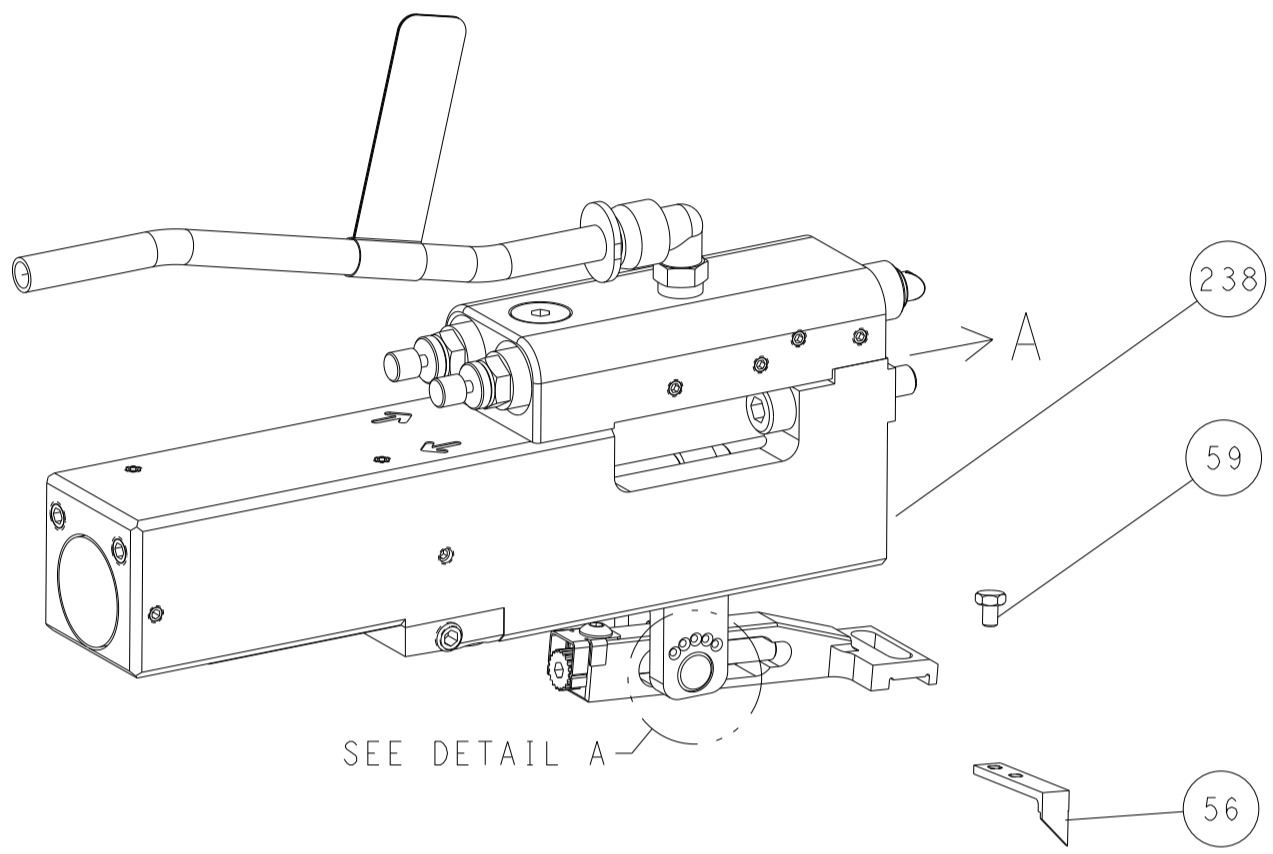

## FEED SPRING SETTING POSITION (SHOWN FROM REAR SIDE)

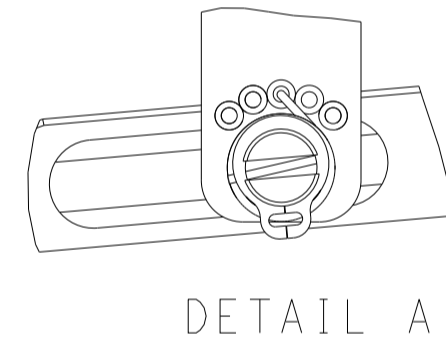

## CAM POSITIONS

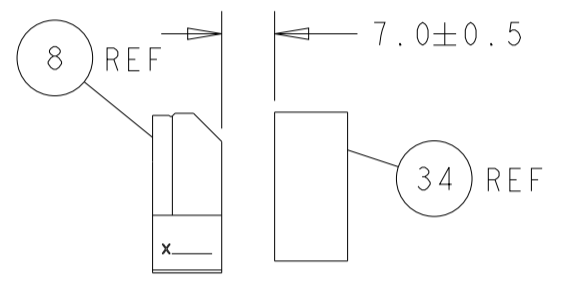
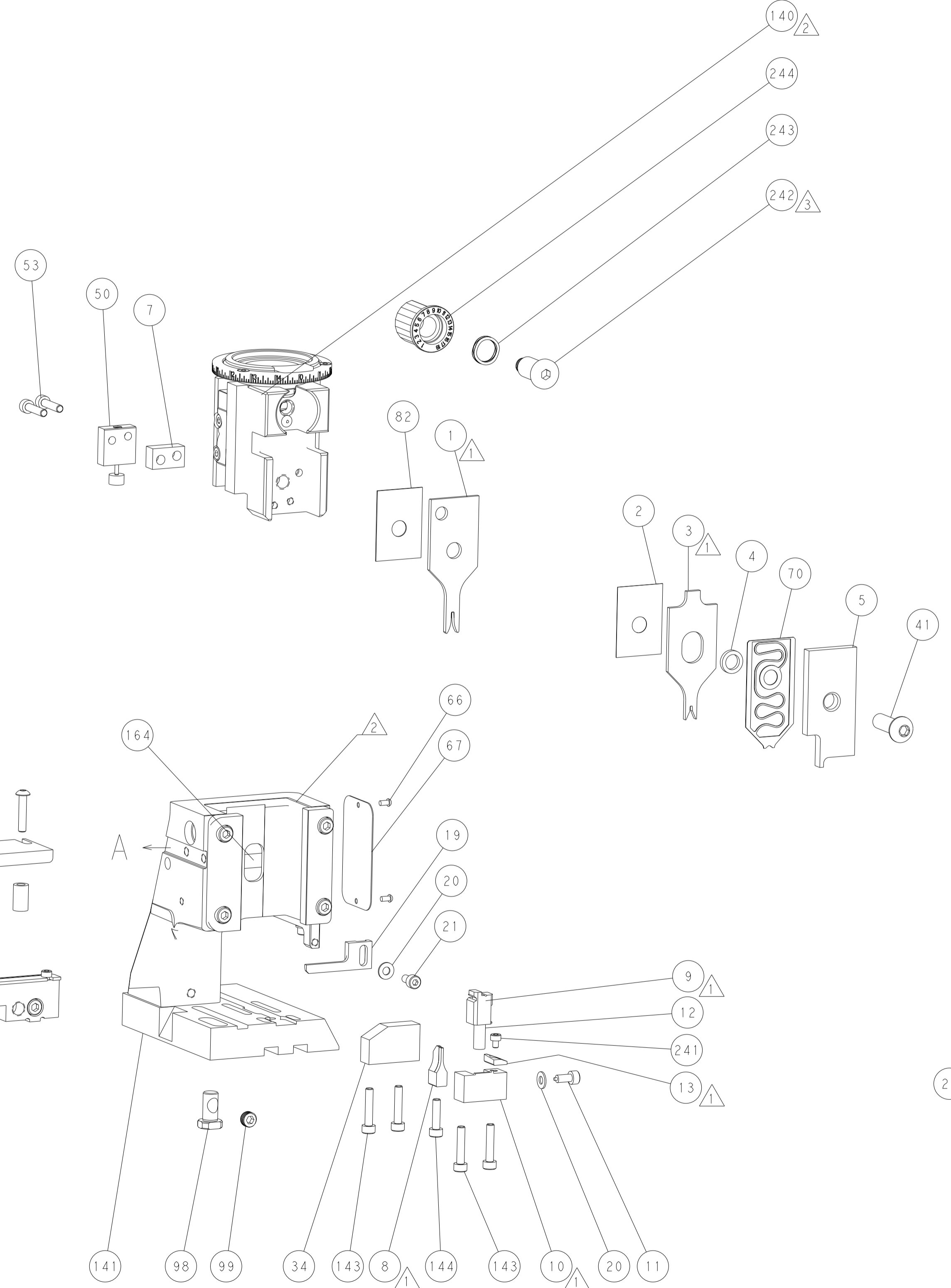
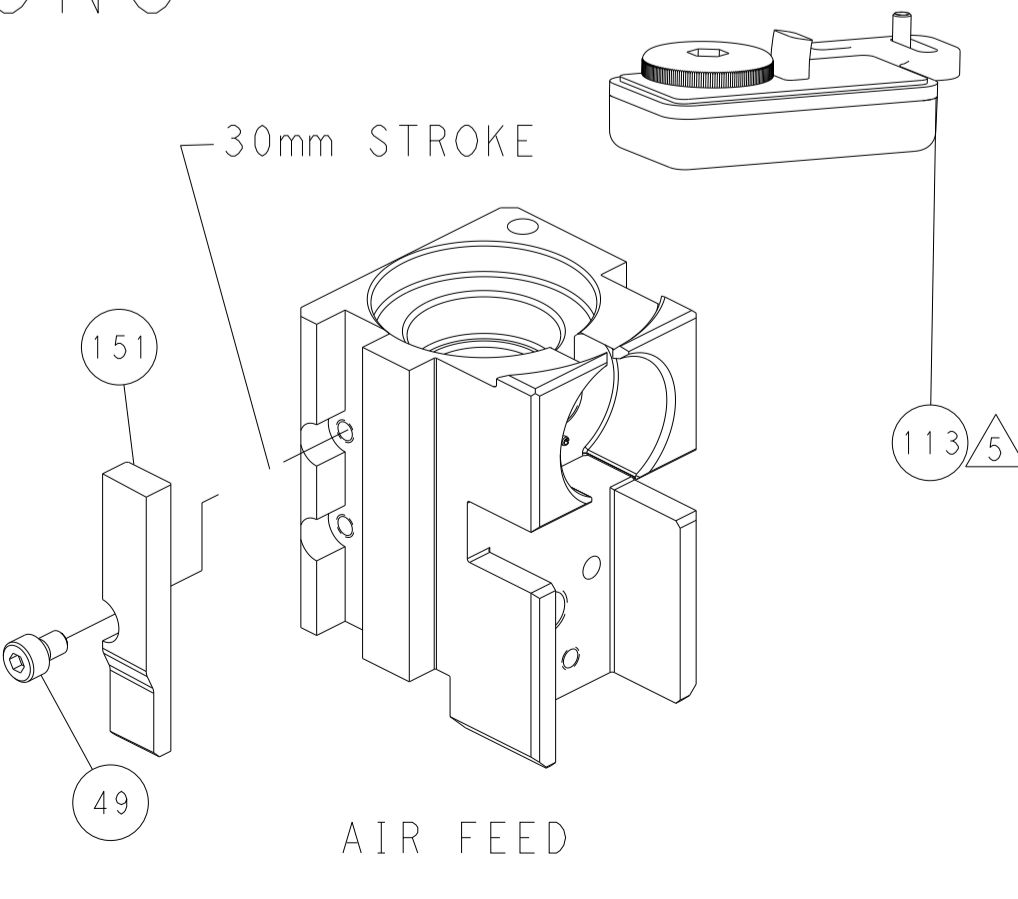
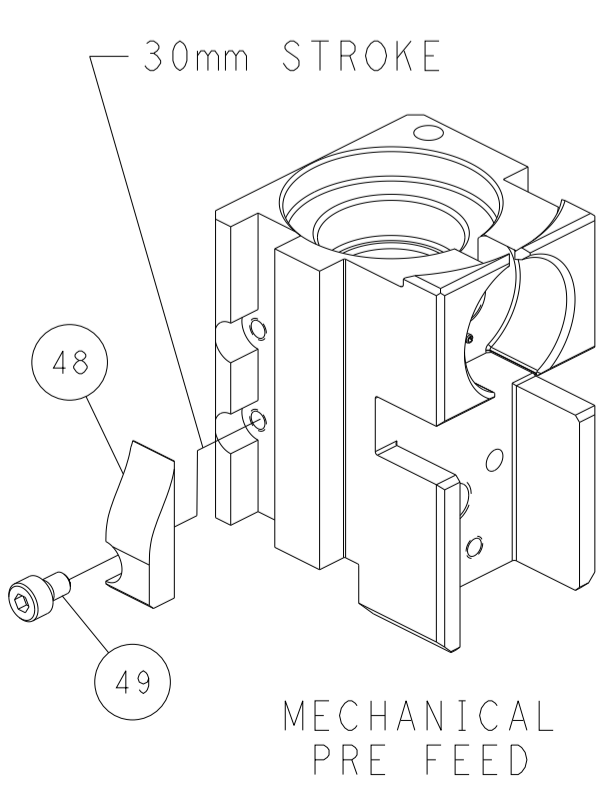
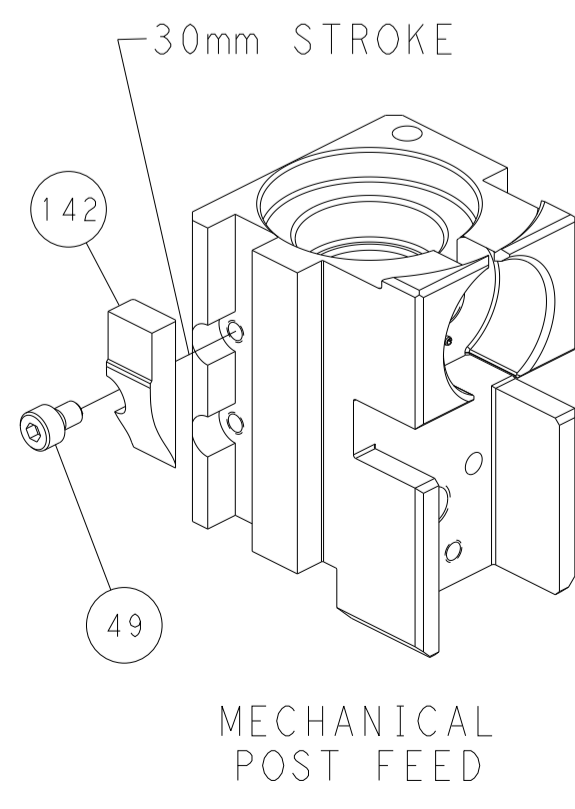

TERMINAL SUPPORT LOCATION

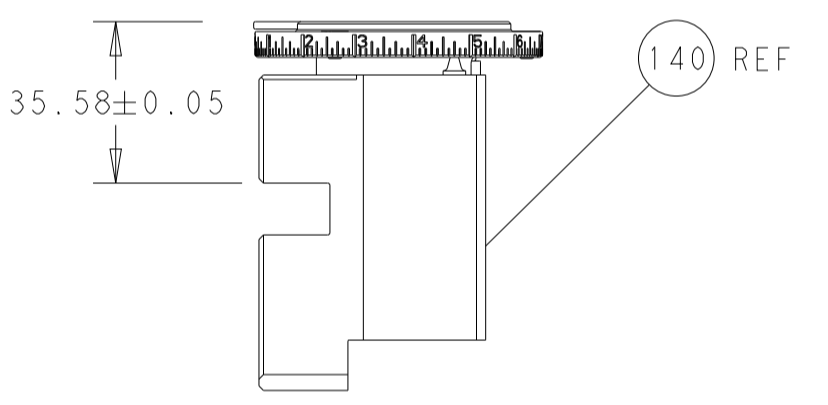

RAM SET-UP

ITEM 30 LOCATED AT FRONT HOLES

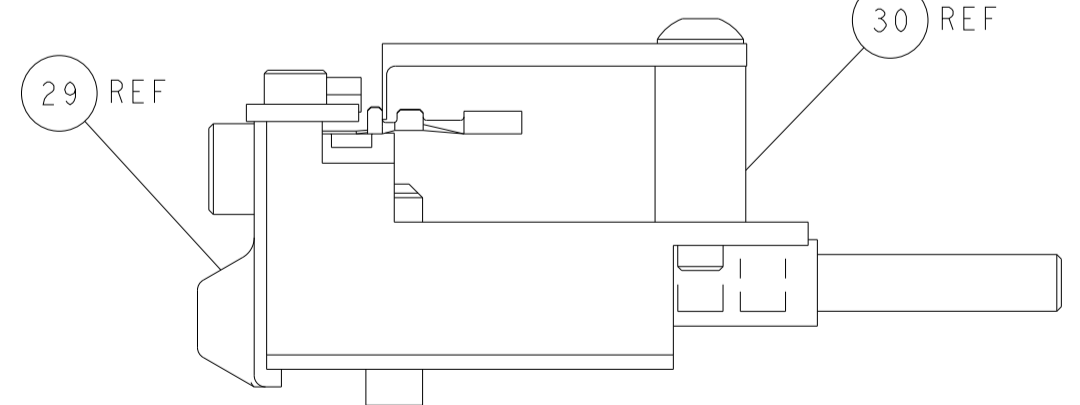

FEED TRACK POSITION GUIDE BY INSULATION BARREL

**PACIFIC VERSION**  
 Shown on sheets 3 of 4 & 4 of 4  
 (Atlantic version shown on sheets 1 of 4 & 2 of 4)

<small>THIS DRAWING IS A CONTROLLED DOCUMENT FOR TYCO ELECTRONICS CORPORATION. IT IS THE PROPERTY OF TYCO ELECTRONICS CORPORATION AND IS NOT TO BE REPRODUCED OR TRANSMITTED IN ANY FORM OR BY ANY MEANS, ELECTRONIC OR MECHANICAL, INCLUDING PHOTOCOPYING, RECORDING, OR BY ANY INFORMATION STORAGE AND RETRIEVAL SYSTEM, WITHOUT THE WRITTEN PERMISSION OF TYCO ELECTRONICS CORPORATION.</small>		DWN L. ZHANG 10AUG2011 CHK L. ZHANG 10AUG2011 APVD S. XI 10AUG2011	TE Connectivity Harrisburg, PA 17105-3608
DIMENSIONS: mm TOLERANCES UNLESS OTHERWISE SPECIFIED: 0 PLC ± 1 PLC ± 2 PLC ± 3 PLC ± 4 PLC ± ANGLES FINISH ±		NAME Ocean Side Feed Applicator SIZE CAGE CODE DRAWING NO A1 00779 C=2151216	RESTRICTED TO SCALE 1:2 SHEET 4 OF 4 REV J3
MATERIAL:		WEIGHT:	Customer Accessible Production Drawing